



NAN YA PLASTICS CORPORATION

SPECIFICATION OF LCD MODULE

PRODUCT NO.: LVC75Z779VS_

SPEC. NO.: LM779-0-△

CUSTOMER
APPROVED BY
DATE:

LCD DEPARTMENT
 ELECTRONIC MATERIALS DIVISION
 NAN YA PLASTIC CORPORATION
 NO.336, NANKAN RD., SEC. 1, LUCHU
 VILLAGE, TAOYUAN COUNTY, TAIWAN
 TEL:886-3-3223751 EXT. 2715~2718
 FAX:886-3-3125803
 E-mail:lcdsales@npc.com.tw

EDITED ON : May. 27, 2008

Q.C. DEPT.	DESIGN MANAGER	DESIGN CHECK	DESIGNER
			W.R.HSU

1.MECHANICAL SPECIFICATION

1.1 Description

The module is a transmissive type's TFT (Thin Film Transistor) active matrix color liquid crystal display (LCD) comprising an amorphous silicon TFT attached to each signal electrode. This model is consisting of TFT-LCD module, a driver circuit and a back-light unit. The resolution of a 3.5" contains 320×240 pixels and can display up to 16.7M colors.

1.2 Features

- Transmissive type and back-light with six LEDs (Light Emitting Diodes)
- Support digital 24-bits parallel RGB interface
- Serial Peripheral Interface(SPI)
- Source and Gate Driver IC: HX8238
- Line inversion driving scheme.
- Image Reversion : Up/Down and Left/Right

1.3 Applications

Designed for camcorder, digital camera application and other electronic products which require high quality flat panel displays.

1.4 General Information

Items	Main-Panel	Unit
LCD type	3.5" TFT-LCD	
Active Area	70.08(H)*52.56(V)	mm
LCD type	Transmissive type	
Driving IC	HX8238	
Display Color	16.7M	color
Number of Pixel	320(H)*RGB*240(V)	pixel
Pixel Pitch	0.073(H)*0.219(V)	mm
Display mode	Normally White	
Viewing direction	6	o'clock

1.5 Mechanical Information

Items		Min.	Typ.	Max.	Unit	Note
Module size	Horizontal(H)	76.7	76.9	77.1	mm	
	Vertical(V)	63.7	63.9	64.1	mm	
	Depth(D)	-	-	3.3	mm	
Weight		-	28.5	-	g	

2.ABSOLUTE MAXIMUM RATINGS

2-1. Absolute Ratings of Environment

Item	Symbol	Value	Unit	Note
Operating temperature	Topr	-10 to 60	°C	
Storage temperature	Tstg	-20 to 70	°C	

Ta = 25 ± 2°C

2-2. Electrical Absolute Ratings

2-2-1 TFT-LCD Module

Item	Symbol	Condition	Min.	Max.	Unit	Remark
Power Voltage	V _{CC}	GND=0	2.5	3.6	V	(1)
Input Signal Voltage	V _{in}	GND=0	2.5	3.6	V	
Logic Output Voltage	V _{out}	GND=0	-	5	V	

Ta = 25 ± 2°C

Note:

(1) Device is subject to be damaged if stresses beyond those absolute maximum ratings.

2-2-2 Back-Light Unit

Item	Symbol	Min.	Max.	Unit	Note
Current	I _F	-	20	mA	(1)

Note:

(1) One LED current maximum absolute ratings.

3.ELECTRICAL CHARACTERISTICS

3.1 TFT-LCD Module Operating conditions :

Items	Symbol	Min.	Typ.	Max.	Unit	Remark
Power Voltage	V _{CC}	2.5	-	3.6	V	
Low level input voltage	V _{IL}	0	-	0.2 V _{CC}	V	
High level input voltage	V _{IH}	0.8 V _{CC}	-	V _{CC}	V	
Analog operating current	I _{AVDD}	-	-	TBD	mA	Note (1)

Ta = 25 ± 2°C

Note (1) DOTCLK=6.5MHZ

Back-Light unit

3.2 Back-Light Unit Electrical Characteristics (Ta = 25 ± 2°C)

Item	Symbol	Min.	Typ.	Max.	Unit	Condition
Forward Voltage	V _F	-	19.2	-	V	I _F = 20mA
Power Consumption	P _{WF}	-	384	-	mW	-

4.OPTICAL CHARACTERISTICS

Item	Symbol	Condition	Min.	Typ.	Max.	Unit	Note	
Contrast ratio (center point)	CR		200	300	-	-	(1) BM-7	
Luminance of white (Center point)	YL		260	300	-	cd / m ²	(4) BM-7	
Response time	T _R	$\theta = 0$	-	15	-	ms	(2)	
	T _F	$\phi = 0$	-	35	-	ms		
Color chromaticity (CIE 1931)	White	W _x	(Normal Viewing Angle) B / L on	0.25	0.30	0.35	-	(4) BM-7
		W _y		0.28	0.33	0.38		
	Red	R _x		0.59	0.64	0.69		
		R _y		0.30	0.35	0.40		
	Green	G _x		0.27	0.32	0.37		
		G _y		0.56	0.61	0.66		
	Blue	B _x		0.09	0.14	0.19		
		B _y		0.05	0.10	0.15		
Viewing angle	Hor.	θL	CR ≥ 10 B / L on	-	70	-	Degrees	(3)
		θR		-	70	-		
	Ver	ϕH		-	35	-		
		ϕL		-	60	-		

T_a = 25 ± 2°C

Note (1) Contrast ratio is defined as follows

$$CR = \frac{\text{Luminance (brightness) all pixels "White"}}{\text{Luminance (brightness) all pixels "dark"}}$$

(2) Response time is defined as follows

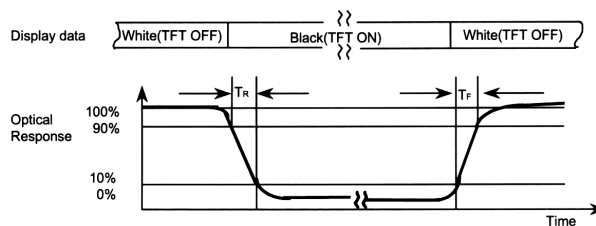

(3) Definition of Viewing Angle

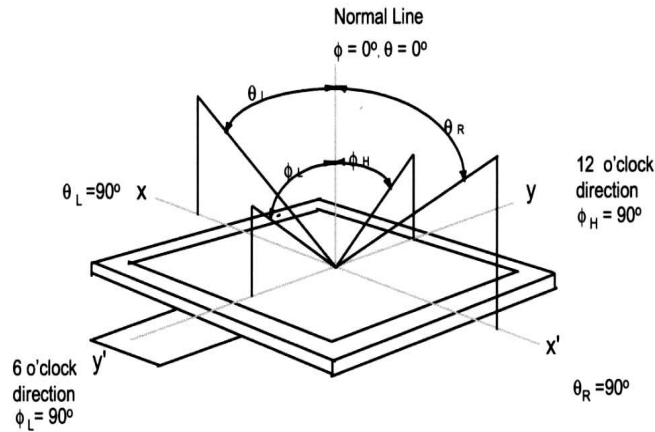

(4) Optical measurement equipment setup

- Measurement should be executed in a stable, windless, and dark room. After lighting the backlight for 30mins.
- Environment condition : Common air conditioner cleanness 、 $T_a = 23 \pm 5^\circ\text{C}$ 、 Humidity = $60 \pm 15\%$
- Distance : 50cm
- Photodetector : BM-7 (Field 1°)

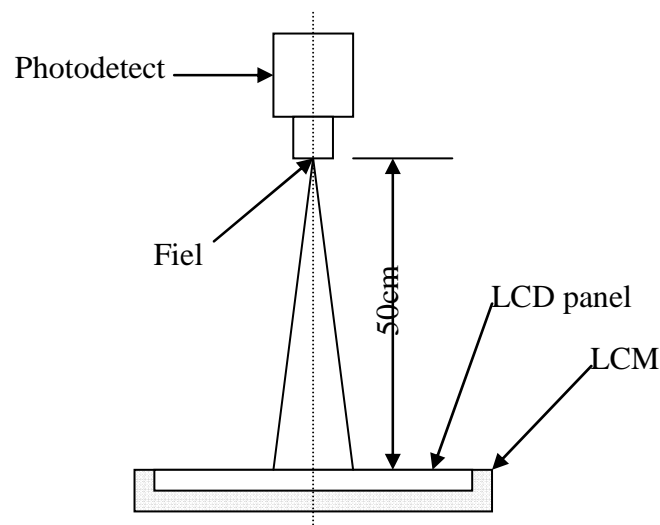

5. Block Diagram

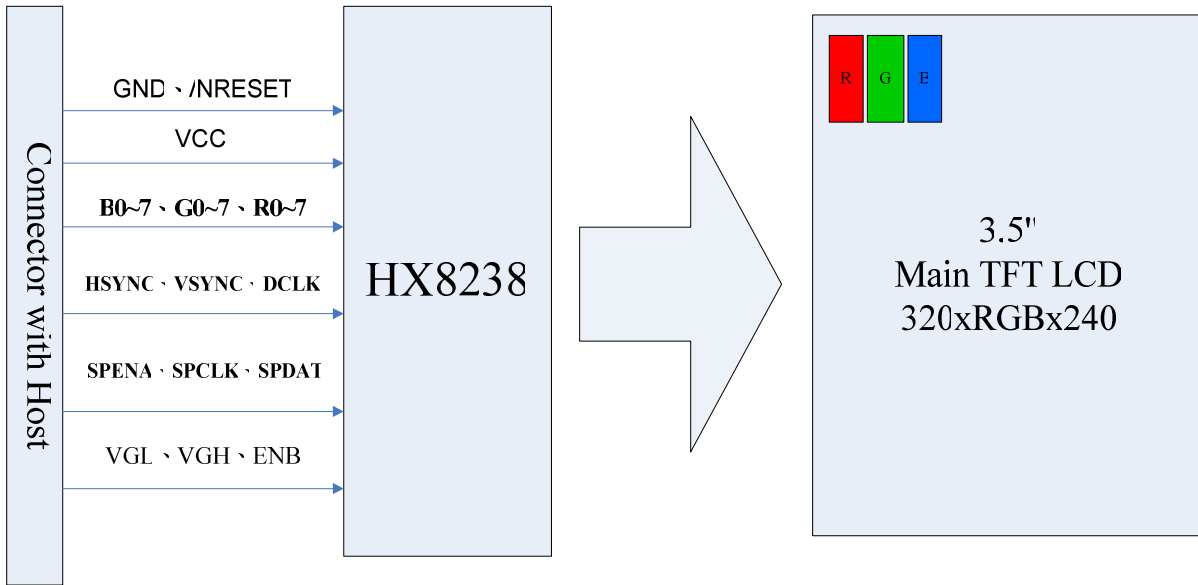

5.1 Back-Light Unit

IF=20mA

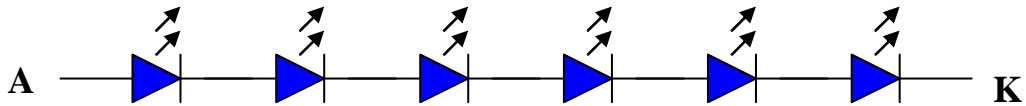

6.INTERNAL PIN CONNECTION

NO	pin name	Description	I/O
1	VBL-	LED_Cathode	P
2	VBL-	LED_Cathode	P
3	VBL+	LED_Anode	P
4	VBL+	LED_Anode	P
5	NC		-
6	/RESET	RESET Signal	I
7	NC		-
8	NC		-
9	NC		-
10	NC		-
11	NC		-
12	B0	Blue Data (LSB)	I
13	B1	Blue Data	I
14	B2	Blue Data	I
15	B3	Blue Data	I
16	B4	Blue Data	I
17	B5	Blue Data	I
18	B6	Blue Data	I
19	B7	Blue Data (MSB)	I
20	G0	Green Data (LSB)	I
21	G1	Green Data	I
22	G2	Green Data	I
23	G3	Green Data	I
24	G4	Green Data	I
25	G5	Green Data	I
26	G6	Green Data	I
27	G7	Green Data (MSB)	I
28	R0	Red Data (LSB)	I
29	R1	Red Data	I
30	R2	Red Data	I
31	R3	Red Data	I

32	R4	Red Data	I
33	R5	Red Data	I
34	R6	Red Data	I
35	R7	Red Data (MSB)	I
36	HSYNC	Horizontal Synchronous Signal	I
37	VSYNC	Vertical Synchronous Signal	I
38	DCLK	Data Clock	I
39	NC		-
40	NC		-
41	VCC	Digital Voltage(2.5~3.6V)	P
42	VCC	Digital Voltage(2.5~3.6V)	P
43	SPENA	Chip Select for Serial port use	I
44	NC		-
45	NC		-
46	NC		-
47	NC		-
48	GND	GROUND	P
49	SPCLK	Serial port Clock.	I
50	SPDAT	Serial port Data input/output.	I/O
51	NC		-
52	ENB	Data enable signal	I
53	GND	GROUND	P
54	GND	GROUND	P

7.SERIAL INTERFACE

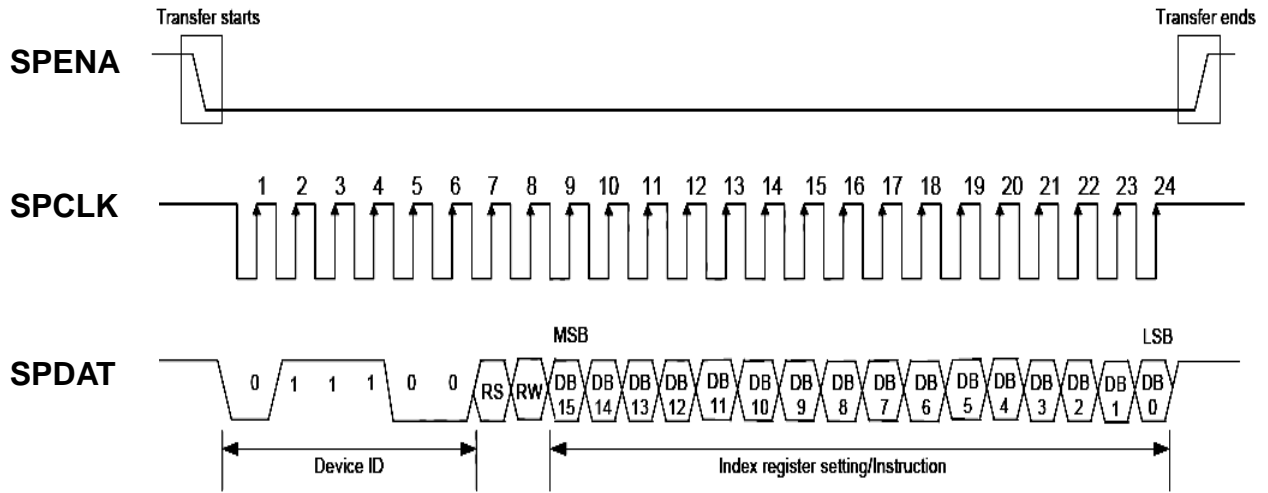

SPI Timing

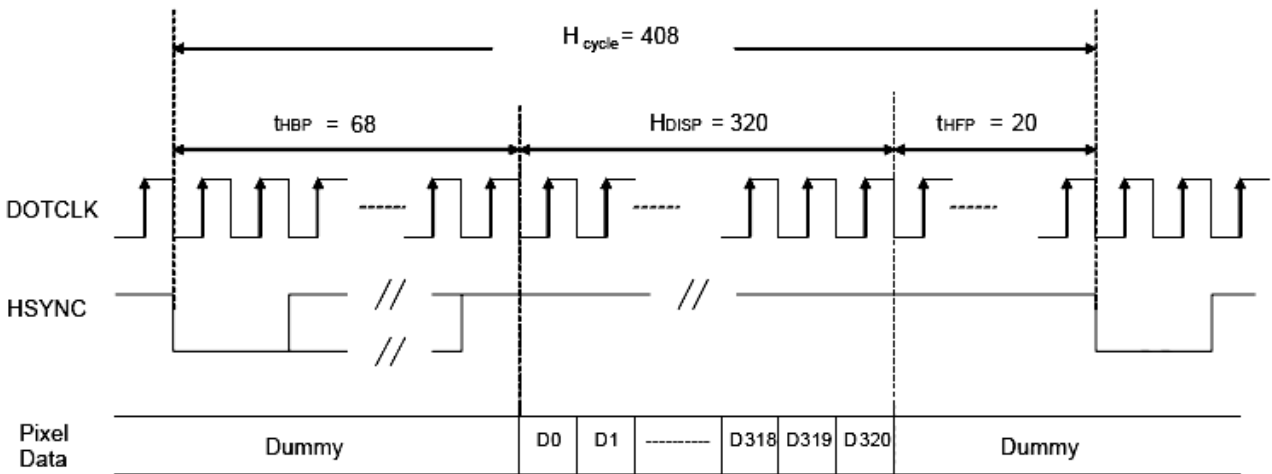

a) Horizontal Data Transaction Timing

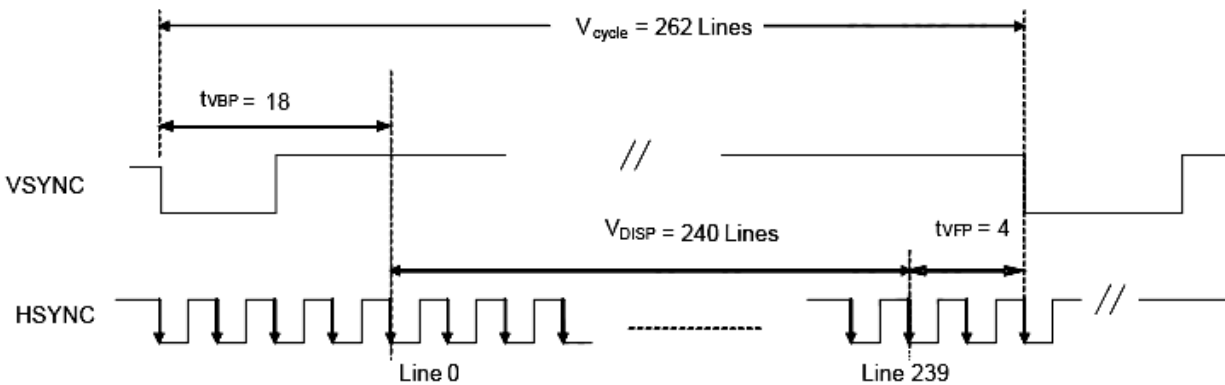

b) Vertical Data Transaction Timing

Data transaction timing in parallel RGB (24 bit) interface (SYNC mode)

Characteristics	Symbol	Min		Typ		Max		Unit
		24 bit	8 bit	24 bit	8 bit	24 bit	8 bit	
DOTCLK Frequency	fDOTCLK	-	-	6.5	19.5	10	30	MHz
DOTCLK Period	tDOTCLK	100	33.3	154	51.3	-	-	ns
Horizontal Frequency (Line)	fH	-	-	14.9		22.35		KHz
Vertical Frequency (Refresh)	fV	-	-	60		90		Hz
Horizontal Back Porch	tHBP	-	-	68	204	-	-	tDOTCLK
Horizontal Front Porch	tHFP	-	-	20	60	-	-	tDOTCLK
Horizontal Data Start Point	tHBP	-	-	68	204	-	-	tDOTCLK
Horizontal Blanking Period	tHBP + tHFP	-	-	88	264	-	-	tDOTCLK
Horizontal Display Area	HDISP	-	-	320	960	-	-	tDOTCLK
Horizontal Cycle	Hcycle	-	-	408	1224	450	1350	tDOTCLK
Vertical Back Porch	tVBP	-	-	18		-		Lines
Vertical Front Porch	tVFP	-	-	4		-		Lines
Vertical Data Start Point	tVBP	-	-	18		-		Lines
Vertical Blanking Period	tVBP + tVFP	-	-	22		-		Lines
Vertical Display Area	VDISP	-	-	240		-		Lines
Vertical Cycle	Vcycle	-	-	262		350		Lines

8. RELIABILITY

NO	ITEM	CONDITION			STANDARD	NOTE
1	High Temp. Storage	70°C	120Hrs		Appearance without defect	
2	Low Temp. Storage	-20°C	120Hrs		Appearance without defect	
3	High Temp. & High Humi. Storage	50°C 90%RH	120Hrs		Appearance without defect	
4	High Temp. Operating Display	60°C	120Hrs		Appearance without defect	
5	Low Temp. Operating Display	-10°C	120Hrs		Appearance without defect	
6	Thermal Shock	-20°C, 30min → 70°C, 30min  (1cycle)			Appearance without defect	10 cycles

9. LCM outgoing inspection criteria

9.1 Definition

(1) Dot : Single pixel

(2) Defect size definition : $D = ((L) + (W)) / 2$

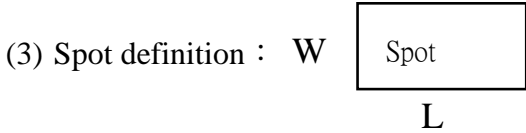

(5) Visual area definition : 0.5mm extended from active area.

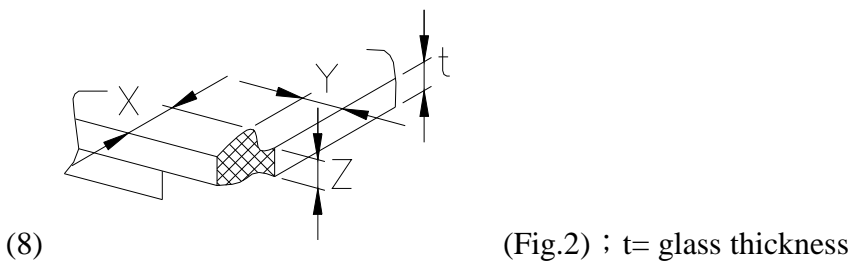
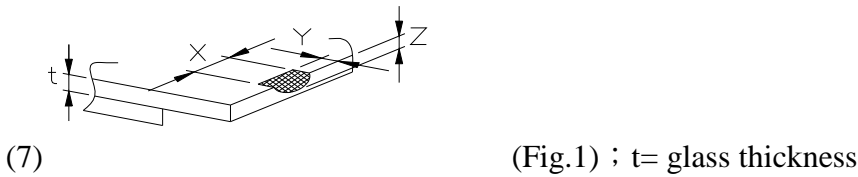
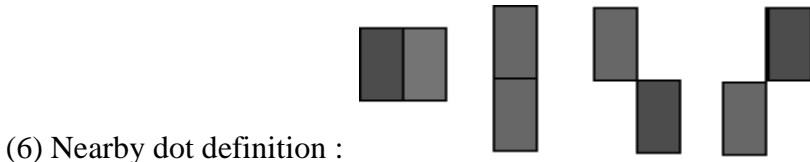

9.2 Procedure/content

(1) Equipment and material :

check samples	limit sample
check tools	magnifier 、 magnification lamp 、 tool 、 B/L lamp 、 air ionizer
check rulers	wire gauges 、 caliper rules
Wiper	Clean Cloth
Solvent(Cell 、 COG 、 OLB)	ethanol (for Cell 、 COG 、 OLB)
Power Supply	--

(2) Inspection Environment :

- a. Temperature : 15°C~25°C ; Humidity : 55 ±15%
- b. Visual Inspection : Distance between the panel and eyes is about 20~30cm, and the illumination is larger than 500Lux for product inspection.
- c. Electrical Characteristic : Distance between the panel and eyes is about 20~30cm, and the illumination is smaller than 300Lux, B/L illumination is between 2500~2800 cd/m² for product inspection.

(3) Sampling Method :

- a. Outline Size Specification : 5pcs/Lot , 0Ac/1Re.
- b. Electrical Inspection : Sampling of Inspection ANSI/ASQC Z1.4(AQL 0.65) Normal Inspection Level II, Single Sampling.
- c. Visual Inspection : Sampling of Inspection ANSI/ASQC Z1.4(AQL 1.0) Normal Inspection Level II, Single Sampling.

(4). LCM outgoing inspection criteria

Category	Item	Defect specification description	Method	SPEC	Criteria	Note	
Visual Inspection	FPC	bend	Visual	Scar bend are not allow			
		scratch		PAD area:	Not allow		
				Non PAD area: can not damage protection film			
	dirty 、broken 、lack parts 、plate peeling		Not allow				
	B/L	Black spot, white spot, other defect	Magnifier	D ≤ 0.2mm		Ignore	Ignore the spot distance while bright dot is in spec.
				0.2mm < D ≤ 0.5mm		2	
				D > 0.5mm		0	
		Scratch, line defect		W ≤ 0.03mm	L ignore	Ignore	
				0.03mm < W ≤ 0.08mm	L ≤ 4mm	4	
				W > 0.08mm	L > 4mm	0	
	The distance between two spot should be larger than 5mm						
	Bezel	Dirty, oil sludge, corrosion	Visual	Not allow			
		scratch		W > 0.1mm	L > 10mm	3	
				W ≤ 0.1mm	L ≤ 10mm	Ignore	

SPECIFICATION

Category	Item	Defect specification description	Method	SPEC	Criteria	Note
Visual Inspection	Panel	surface crack	Visual	X ignore ; $Y \leq 0.4 \text{ mm}$; $Z \leq t$	Ignore	Fig.1
				$X \leq 2 \text{ mm}$; $0.4 \text{ mm} \leq Y \leq 1.3 \text{ mm}$; $Z \leq t$		
		Crack		Any crack:	Not allow	
	Silicone Coating	Glue		Panel area: Glue over polarizer is not allowed		
				Around panel area :	Not allow	
				Not allow		
		Coating		IC area : Coating all IC		
				Pad area : Coating all the circuits		
	Polarizer	Stab 、 scratch 、 dent		Active area:	Not allow	
		Polarizer bubble		Outside visual area:	Ignore	
		Concave 、 protruding		Active area:	Not allow	
				Outside visual area:		
		Shift		Active area : $D \leq 0.75 \text{ mm}$	Ignore	
				Outside visual area:	Ignore	
Total line defect					4	
Total dot defect					4	

SPECIFICATION

Category	Item	Defect specification description	Method	SPEC	Criteria	Note			
Electrical Inspection	Display	No display	Visual	Not allow					
	Line defect	Any line defect	Visual	Not allow					
	Mura	Mura/gap/rubbing	Visual	Limit sample	Can not worse than limit sample				
		White/black spot		Not allow					
		Flicker 、 noise		Not allow					
	Bright dot	BM hole	Magnifier	D ≤ 1/2 Dot		Ignore	Ignore the spot distance while bright dot is in spec.		
				1/2 Dot < D ≤ 1Dot		2			
				Visual area	D ≤ 0.1mm	Ignore			
					0.1mm < D ≤ 0.15mm	2			
					D > 0.15mm	0			
				Outside visual area:	D ≤ 0.3mm	Ignore			
					0.3mm < D ≤ 0.5mm	1			
					D > 0.5mm	0			
				The distance between two BM hole should be larger than 5mm					
				Nearby bright dot				Not allow	
	Total bright dot				3				
	Dark dot	RGB dark dot	Magnifier	D ≤ 1 Dot		2			
				1 Dot ≤ D ≤ 2 Dot		1			
		Nearby dark dot		1 Dot ≤ D ≤ 2 Dot		1Pair			
		Total dark dot		2 nearby dark dot counted as 2 points		3			
Polarizer defect	Spot, line defect	Magnifier	D ≤ 0.15 mm		Ignore				
			0.15mm < D ≤ 0.25mm		3				
			The distance between two spot should be larger than 5mm						
Total dot(dark +bright)				4	Include bright dot, dark dot, CF bright dot, BM hole, polarizer bright dot				
Distance	Distance between 2 bright dot 、 bright and dark dot 、 2 dark dot	check rulers	The distance between two spot should be larger than 5mm						

10. GENERAL PRECAUTIONS

10.1. Handling

- (a) When the module is assembled, it should be attached to the system firmly. Be careful not to twist and bend the module.
- (b) Refrain from strong mechanical shock and / or any force to the module. In addition to damage, this may cause improper operation or damage to the module and back-light unit.
- (c) Note that polarizers are very fragile and could be easily damaged. Do not press or scratch the surface harder than a HB pencil lead.
- (d) Wipe off water droplets or oil immediately. If you leave the droplets for a long time, Staining and discoloration may occur.
- (e) If the surface of the polarizer is dirty, clean it using some absorbent cotton or soft cloth.
- (f) The desirable cleaners are water, Isopropyl Alcohol or Hexane.
- (g) If the liquid crystal material leaks from the panel, it should be kept away from the eyes or mouth. In case of contact with hands, legs or clothes, it must be washed away thoroughly with soap.
- (h) Use finger-stalls with soft gloves in order to keep display clean during the incoming inspection and assembly process.
- (i) Do not disassemble the module.
- (j) Protection film for polarizer on the module shall be slowly peeled off just before use so that the electrostatic charge can be minimized.

10.2. Storage

- (a) Do not leave the Panel in high temperature, and high humidity for a long time. It is highly recommended to store the module with temperature from 0 to 35°C and relative humidity of less than 70%.
- (b) Do not store the TFT-LCD module in direct sunlight.
- (c) The module shall be stored in a dark place. It is prohibited to apply sunlight or fluorescent light during the store.

10.3. Applicable warrant period

- (a) The period is within twelve months since the date of shipping out under normal using and storage conditions.

10.4. Other

- (b) When in operations, do not connect; disconnect the module in the "Power on" condition.
- (c) The liquid crystal is deteriorated by ultraviolet; do not leave it in direct sunlight and strong ultraviolet ray for hours.
- (d) Avoid condensation of water. It may result in improper operation or disconnection of electrode.
- (e) Do not exceed the absolute maximum rating value. Otherwise the panel may be damaged.
- (f) If the panel displays the same pattern continuously for a long period of time, it can be the situation when the image "Stick" to the screen
- (g) The max temperature / continuous time of FPC soldering are 320°C / 5 seconds.

11. OUTLINE DIMENSION

