



NAN YA PLASTICS CORPORATION

SPECIFICATION OF LCD MODULE

PRODUCT NO.: LVC46Z806YS_

SPEC. NO.: LM806-0-△

CUSTOMER
APPROVED BY
DATE:

LCD DEPARTMENT
ELECTRONIC MATERIALS DIVISION
NAN YA PLASTIC CORPORATION
201, TUNG HWA N. ROAD, TAIPEI
TEL:886-2-27122211 EXT.5993~5996
FAX:886-2-27178253
E-mail:lcdsales@npc.com.tw

EDITED ON : Feb. 12, 2008

Q.C. DEPT.	DESIGN MANAGER	DESIGN CHECK	DESIGNER
			W.R.HSU

1.MECHANICAL SPECIFICATION

1.1 Description

The module is a transmissive type's TFT (Thin Film Transistor) active matrix color liquid crystal display (LCD) comprising an amorphous silicon TFT attached to each signal electrode. This model is consisting of TFT-LCD module, a driver circuit and a back-light unit. The resolution of a 2.4" contains 240×320 pixels and can display up to 262K colors.

1.2 Features

- Transmissive type and back-light with Four LEDs (Light Emitting Diodes)
- RGB 16-bit interface
- Source and Gate Driver IC: R61505U
- Full, Still, Sleep & Stand-by modes are available
- Line inversion mode
- Low Power consumption

1.3 Applications

Display terminals for mobile phone application products.

1.4 General Information

Items	Main-Panel	Unit
LCD type	2.4" TFT-LCD	
Active Area	36.72(H)*48.96(V)	mm
LCD type	Transmissive type	
Driving IC	R61505U	
Display Color	262K	color
Number of Pixel	240(H)*RGB*320(V)	pixel
Pixel Pitch	0.153(H)*0.153(V)	mm
Display mode	Normally White	
Viewing direction	12	o'clock

1.5 Mechanical Information

Items		Min.	Typ.	Max.	Unit	Note
Module size	Horizontal(H)	42.52	42.72	42.92	mm	
	Vertical(V)	64.26	61.46	61.66	mm	
	Depth(D)	-	-	2.9	mm	含焊厚
Weight		-	12	-	g	

2.ABSOLUTE MAXIMUM RATINGS

2-1. Absolute Ratings of Environment

Item	Symbol	Value	Unit	Note
Operating temperature	Topr	-20 to 70	°C	
Storage temperature	Tstg	-30 to 80	°C	

Ta = 25 ± 2°C

2-2. Electrical Absolute Ratings

2-2-1 TFT-LCD Module

Item	Symbol	Value	Unit	Note
Power supply voltage (1)	VCC,IOVCC	-0.3 to 4.6	V	
Power supply voltage (2)	VCI-AGND	-0.3 to 4.6	V	
Power supply voltage (3)	DDVDH-AGND	-0.3 to 6.5	V	
Power supply voltage (4)	AGND-VCL	-0.3 to 4.6	V	
Power supply voltage (5)	DDVDH-VCL	-0.3 to 9.0	V	
Power supply voltage (7)	AGND-VGL	-0.3 to 13	V	
Power supply voltage (8)	VGH-VGL	-0.3 to 30	V	
Input voltage	V _t	-0.3 to IOVCC +0.3	V	

Ta = 25 ± 2°C

2-2-2 Back-Light Unit

Item	Symbol	Min.	Max.	Unit	Note
Current	I _F	-	20	mA	(1)

Note:

(1) One LED current maximum absolute ratings.

3.ELECTRICAL CHARACTERISTICS

3.1 TFT-LCD Module Operating conditions :

Items	Symbol	Min.	Typ.	Max.	Unit	Note	
Logic supply voltage	V_{CC}	2.5	2.8	3.3	V		
DC/DC supply voltage	V_{CI}	2.5	2.8	3.3	V		
Dissipation current	Stand-by	$(I_{CC}+I_{CI})_{STB}$	-	-	TBD	mA	(1)
	Sleep	$(I_{CC}+I_{CI})_{SLP}$	-	-	TBD		(2)
	Still	$(I_{CC}+I_{CI})_S$	-	-	TBD		(3) (5)
	Full	$(I_{CC}+I_{CI})_F$	-	-	TBD		(4) (5)
Frame frequency	f_{Frame}	-	60	-	Hz		

$T_a = 25 \pm 2^\circ C$

- Note (1) $V_{CC}=V_{CI}=2.8V$, Stand-by mode & No input signals
 (2) $V_{CC}=V_{CI}=2.8V$, Sleep mode & No input signals
 (3) $V_{CC}=V_{CI}=2.8V$, Internal mode & No input signals
 (4) $V_{CC}=V_{CI}=2.8V$, $f_{Vsync}=60Hz$, $R_{frame}=15Frame$
 (5)Dissipation current check pattern

Black Pattern 

3.2 Back-Light Unit

Back-Light Unit Electrical Characteristics ($T_a = 25 \pm 2^\circ C$)

Item	Symbol	Min.	Typ.	Max.	Unit	Condition
Forward Voltage	V_F	-	3.2	-	V	$I_F = 60mA$
Power Consumption	P_{WF}	-	192	-	mW	-

4.OPTICAL CHARACTERISTICS

Item	Symbol	Condition	Min.	Typ.	Max.	Unit	Note	
Contrast ratio (center point)	CR		180	200	-	-	(1) BM-7f	
Luminance of white (Center point)	YL		180	200	-	cd / m ²	(4)BM-7f	
Response time	T _R	$\theta = 0$	-	15	-	ms	(2)	
	T _F	$\phi = 0$	-	35	-	ms		
Color chromaticity (CIE 1931)	White	W _x	(Normal Viewing Angle) B / L on	0.257	0.287	0.317	-	(4) BM-7f
		W _y		0.259	0.289	0.319		
	Red	R _x		0.597	0.627	0.657		
		R _y		0.293	0.323	0.353		
	Green	G _x		0.296	0.326	0.356		
		G _y		0.574	0.604	0.634		
	Blue	B _x		0.113	0.143	0.173		
		B _y		0.029	0.059	0.089		
Viewing angle	Hor.	θL	CR ≥ 10 B / L on	-	45	-	Degrees	(3)
		θR		-	45	-		
	Ver	ϕH		-	35	-		
		ϕL		-	15	-		

T_a = 25 ± 2°C

Note (1) Contrast ratio is defined as follows

$$CR = \frac{\text{Luminance (brightness) all pixels "White"}}{\text{Luminance (brightness) all pixels "dark"}}$$

(2) Response time is defined as follows

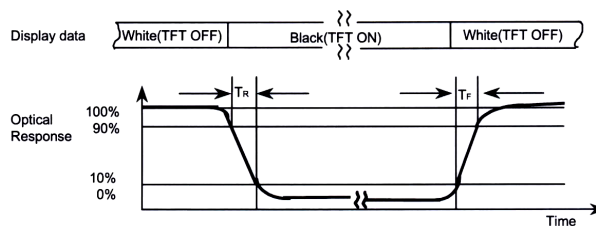

(3) Definition of Viewing Angle

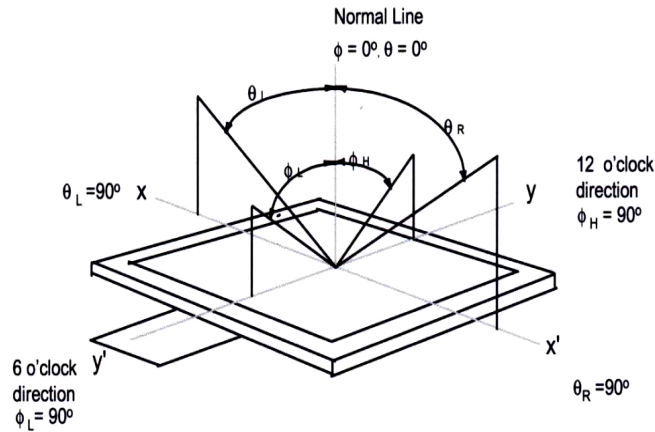

(4) Optical measurement equipment setup

- Measurement should be executed in a stable, windless, and dark room. After lighting the backlight for 30mins.
- Environment condition : Common air conditioner cleanness 、 $T_a=23\pm 5^\circ\text{C}$ 、 Humidity= $60\pm 15\%$
- Distance : 50cm
- Photodetector : BM-7f (Field 1°)

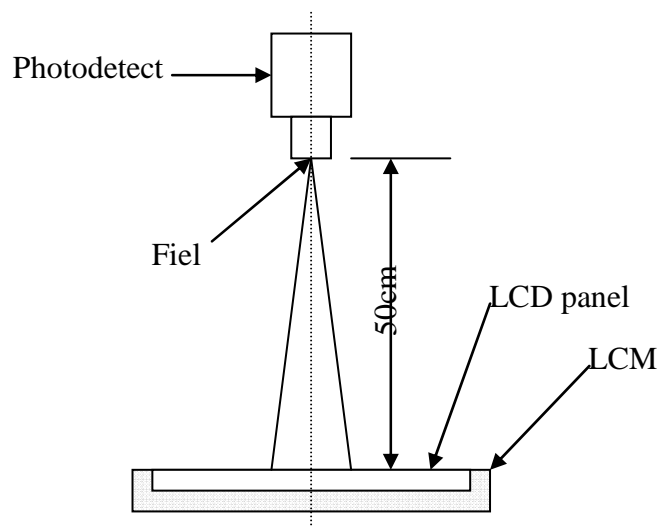

5.BLOCK DIAGRAM

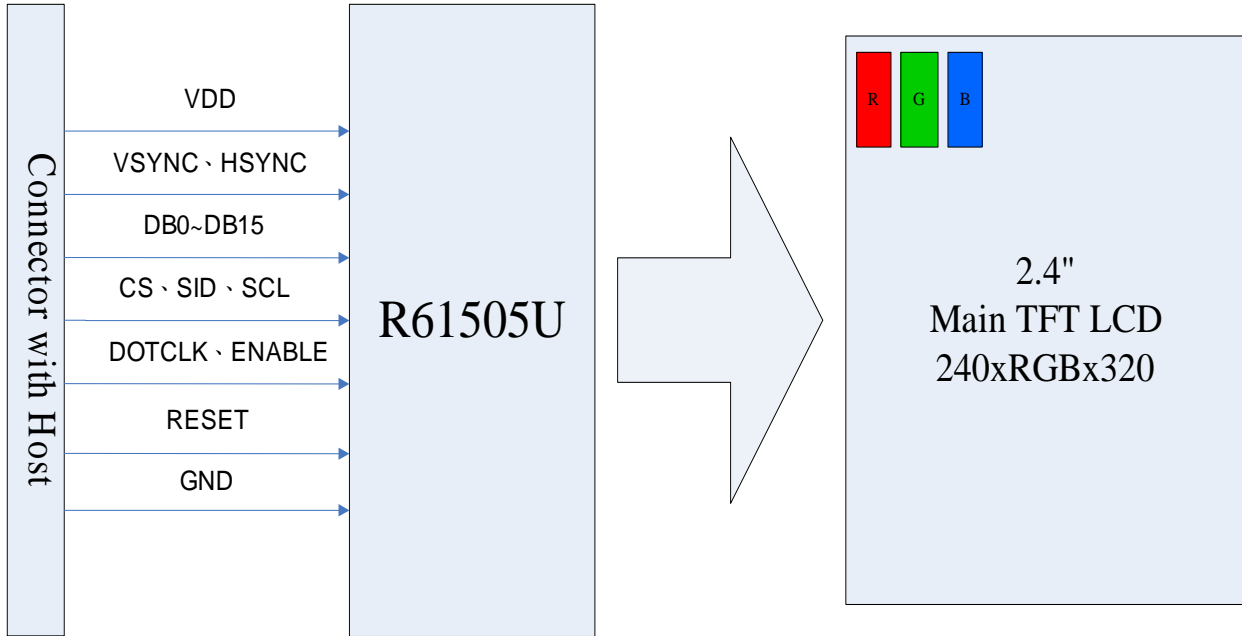

5.1 Back-Light Unit

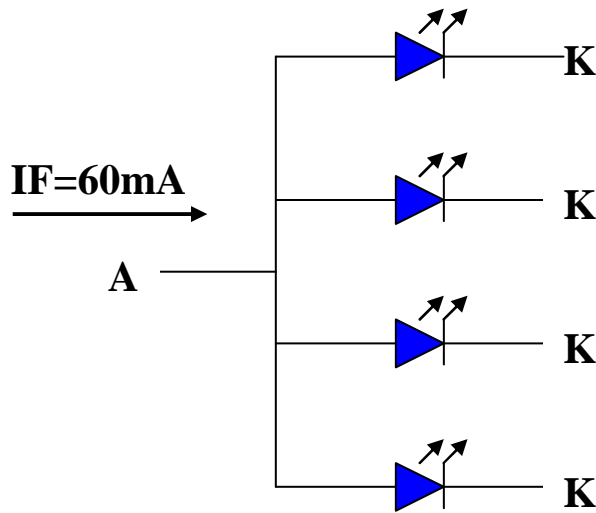

6.INTERNAL PIN CONNECTION

NO.	pin name	Description	Input/Output	Note
1	GND	Ground	I	
2	DB15	Data bus	I	R Data MSB
3	DB14	Data bus	I	R Data
4	DB13	Data bus	I	R Data
5	DB12	Data bus	I	R Data
6	DB11	Data bus	I	R Data LSB
7	DB10	Data bus	I	G Data MSB
8	DB09	Data bus	I	G Data
9	DB08	Data bus	I	G Data
10	DB07	Data bus	I	G Data
11	DB06	Data bus	I	G Data
12	DB05	Data bus	I	G Data LSB
13	DB04	Data bus	I	B Data MSB
14	DB03	Data bus	I	R Data
15	DB02	Data bus	I	R Data
16	DB01	Data bus	I	R Data
17	DB00	Data bus	I	B Data LSB
18	NC	NO USE		
19	NC	NO USE		
20	CS	A chip select signal	I	
21	SDI	Serial data input pin	I	
22	SCL	Synchronous Clock Signal	I	
23	DOTCLK	Clock signal of external interface	I	
24	RESET	System reset	I	
25	HSYNC	Horizontal Synchronous Signal	I	

SPECIFICATION

26	VSYNC	Vertical Synchronous Signal	I	
27	ENABLE	Data enable signal pin	I	
28	GND	Ground	I	
29	NC (X+)XL	T/P Connection pad	I	
30	NC (Y+)YD	T/P Connection pad	I	
31	NC (X-)XR	T/P Connection pad	I	
32	NC (Y-)YU	T/P Connection pad	I	
33	VDD	Voltage: 2.5~3.3	P	
34	VDD	Voltage: 2.5~3.3	P	
35	LED1+	B/L power pin	P	
36	LED2+	B/L power pin	P	
37	LED3+	B/L power pin	P	
38	LED4+	B/L power pin	P	
39	LED-	B/L power pin	P	

7.INTERFACE SPECIFICATIONS

7.1. System Interface

Please refer to **R61505U** datasheet for more details.

7.2. DC characteristics

TFT LCD

Item	Symbol	Test Condition	Min	Max	Unit
Input high voltage	V _{IH}	V _{CC} = 2.5 to 3.3V, Ta =25 ± 2°C	0.8 V _{CC}	V _{CC}	V
	V _{IL}		-	0.2 V _{CC}	
Logic output voltage	V _{OH}	V _{CC} = 2.5 to 3.3V, Ta =25 ± 2°C	0.8 V _{CC}	-	V
	V _{OL}		-	0.2 V _{CC}	

V_{CC}= 2.2 to 3.3V, Ta =25±2°C

7.3. AC Characteristics

TFT LCD

● RGB interface timing characteristics

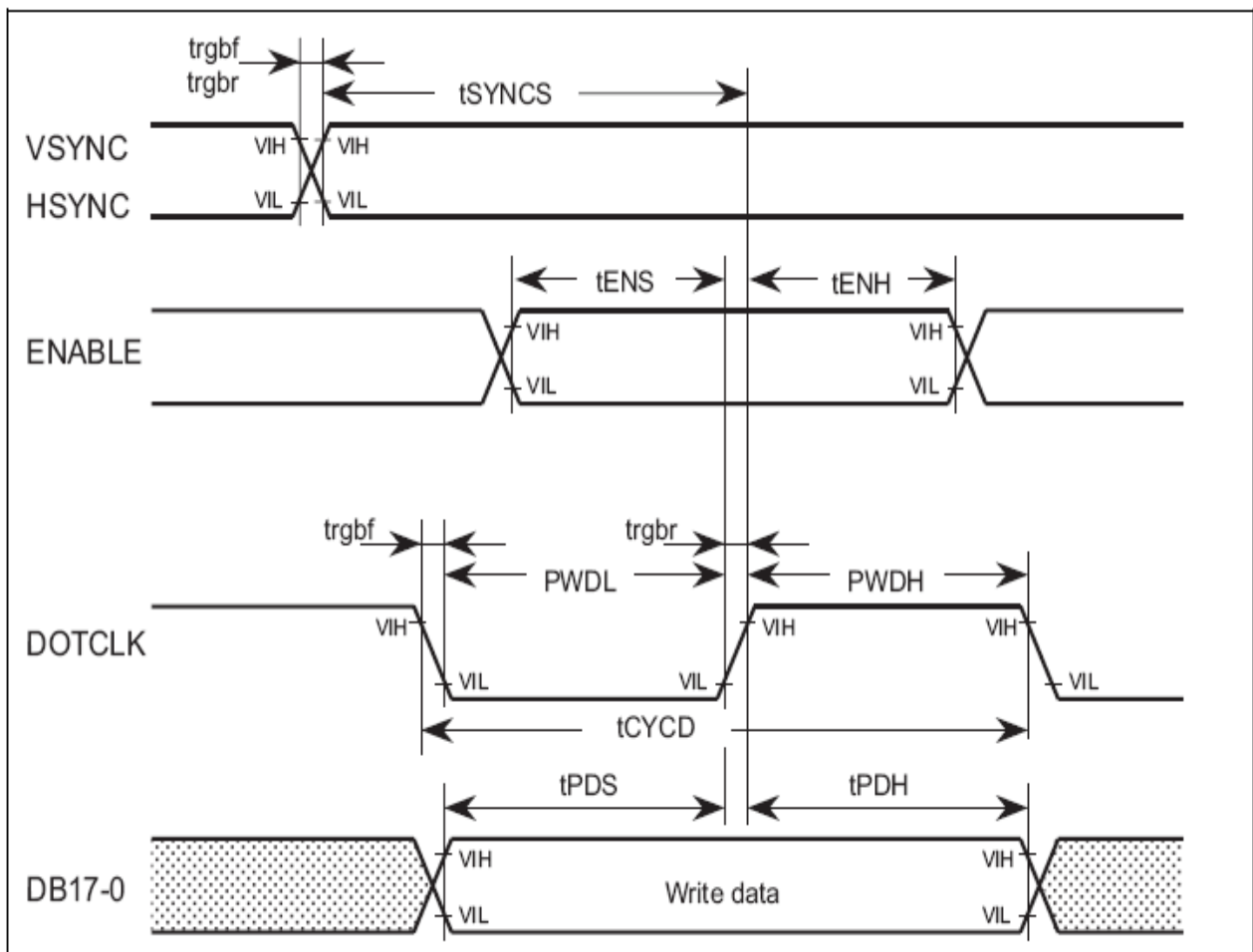

Figure 1

18-/ 16- bit RGB interface (HWM=1) , (V_{cc}=2.4~3.3V ; T_a=25±2°C)

Item	Symbol	Unit	Min.	Typ.	Max.	Timing diagram
VS _{YNC} /HS _{YNC} setup time	t _{SYNCS}	clock	0	-	1	Figure 1
ENABLE setup time	t _{ENS}	ns	10	-	-	Figure 1
ENABLE hold time	t _{ENH}	ns	20	-	-	Figure 1
DOTCLK low-level pulse width	PW _{DL}	ns	40	-	-	Figure 1
DOTCLK high-level pulse width	PW _{DH}	ns	40	-	-	Figure 1
DOTCLK cycle time	t _{CYCD}	ns	100	-	-	Figure 1
Data setup time	t _{PDS}	ns	10	-	-	Figure 1
Data hold time	t _{PDH}	ns	40	-	-	Figure 1
DOTCLK, VS _{YNC} and HS _{YNC} rise/fall time	tr _{gbr} , tr _{gbf}	ns	-	-	25	Figure 1

Item	Symbol	Unit	Min.	Typ.	Max.
Reset low-level width	t _{RES}	ms	1	-	-
Reset rise time	tr _{RES}	µs	-	-	10

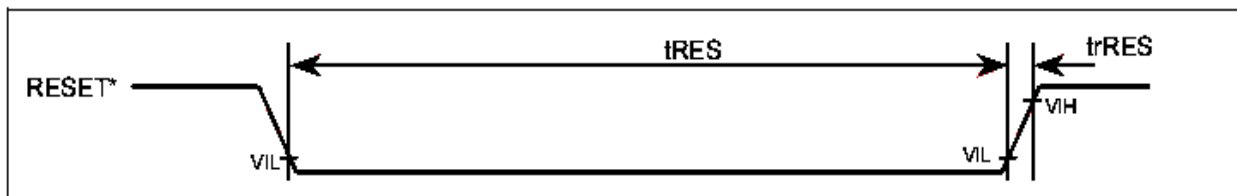
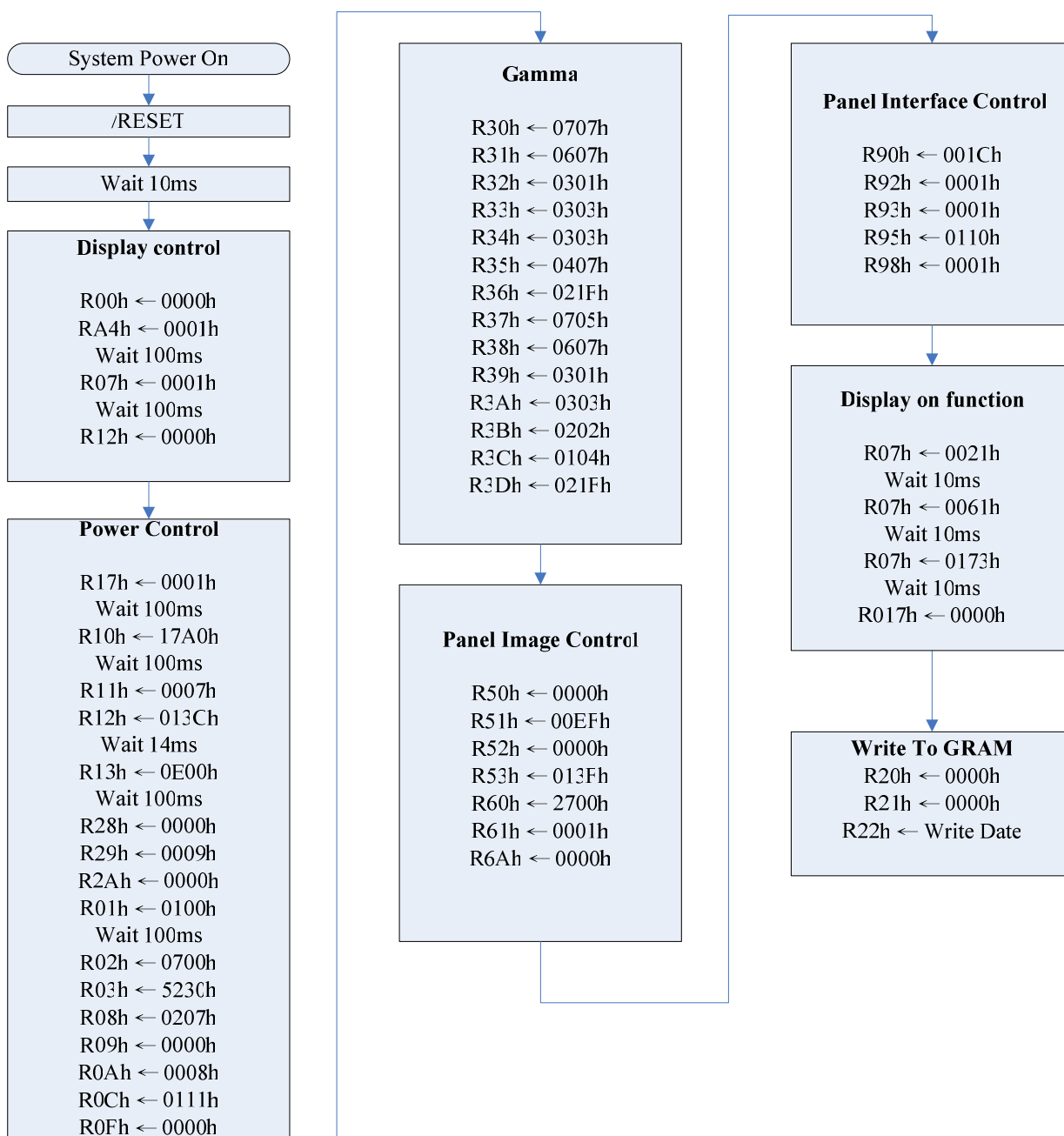

Figure 2

8.INITIAL CODE

8.1. Initial & Power Setting Sequence

< Power Setting Sequence >



緯晶在External Display Interface Control所設的參數值

此值僅供參考，需依據客戶端的設定再做修改

R0Fh ← 0000h

DPL=0 Input data on the rising edge of DOTCLK

EPL=0 Writes data DB17~0 when ENABLE= 0

HSPL=0 Low active

VSPL=0 Low active

8.2. Sleep Mode Setting / Wake up Sequence

Sleep Mode Setting

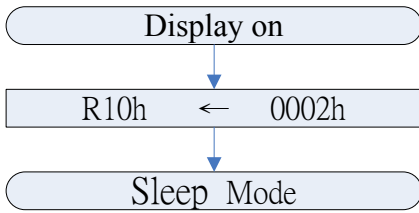

Sleep Mode Wake up

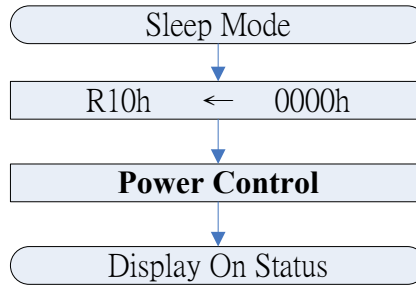

Deep Standby Mode

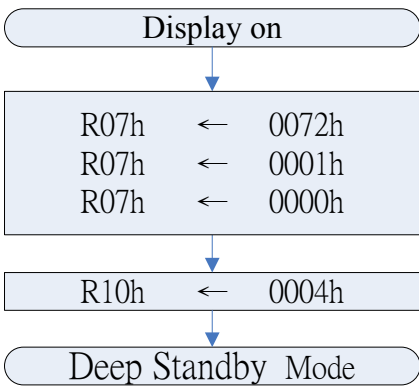

Deep Standby Mode Wake up

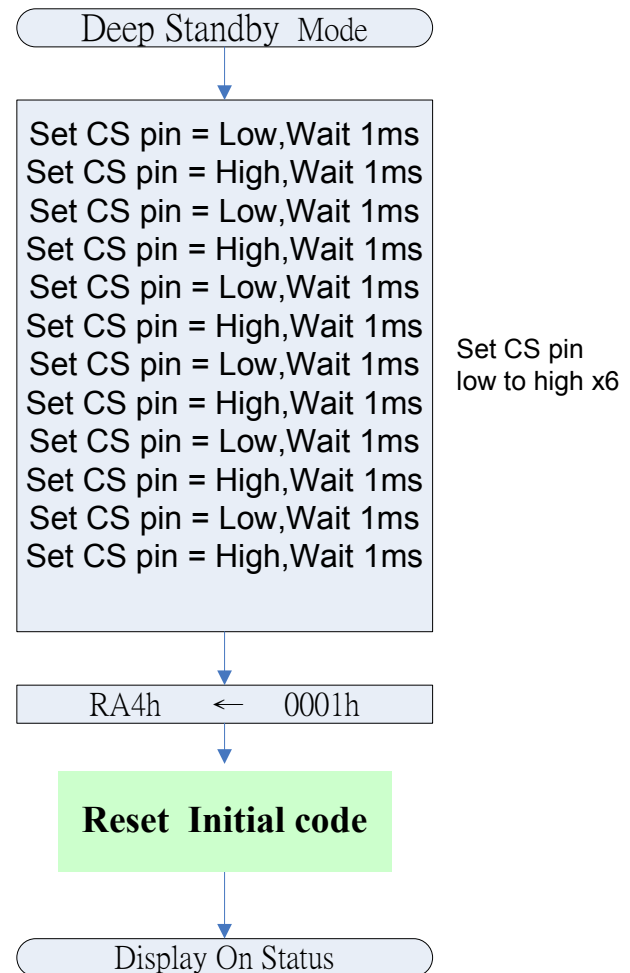

9. RELIABILITY

Contents of Reliability Tests

Item		Purpose	S/S	Conditions	Criterion
Environment Stress	High Temperature Storage	To check the product capability after long time high temperature environment stress.	≧ 5pcs	Ta = 80 ± 2°C 240 hours	Brightness should be within 70% of initial value Operational function is work
	High Temperature / Humidity Storage	To check the product capability after long time high temperature & high humidity environment stress.	≧ 5pcs	Ta = 60 ± 2°C RH = 90 ± 2% 240 hours	
	Thermal Shock	To check the product capability after rapidly stress of different high/low temperature environment change.	≧ 5pcs	-20°C /30 mins ⇔ 25°C /5 mins ⇔ 80°C /30 mins , 10 Cycles	

10. LCM outgoing inspection criteria

10.1 Definition

- (1) Dot : Single pixel
- (2) Defect size definition : $D = ((L) + (W)) / 2$

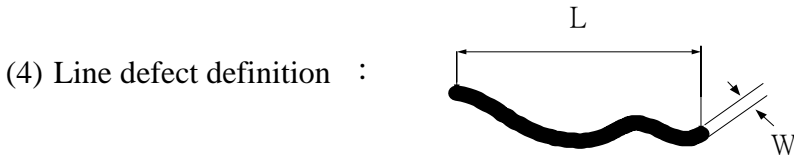
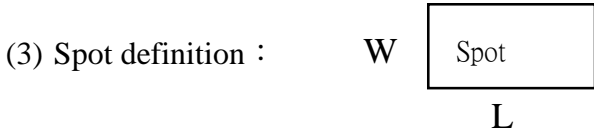

- (5) Visual area definition : 0.5mm extended from active area.

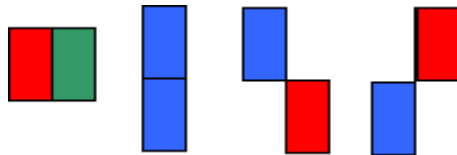

- (5) Nearby dot definition :

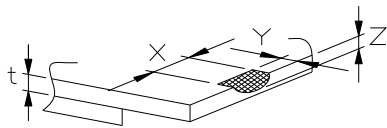

(6) (Fig.1) ; t= glass thickness

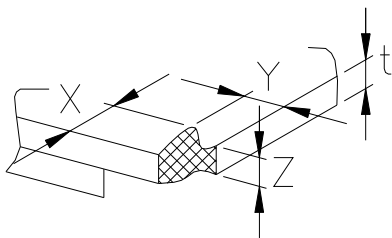

(7) (Fig.2) ; t= glass thickness

10.2 Procedure/content

- (1) Equipment and material :

check samples	limit sample
check tools	magnifier 、 magnification lamp 、 tool 、 B/L lamp 、 air ionizer
check rulers	wire gauges 、 caliper rules
Wiper	Clean Cloth
Solvent(Cell 、 COG 、 OLB)	ethanol (for Cell 、 COG 、 OLB)
Power Supply	--

(2) Inspection Environment :

- a. Temperature : 15°C~25°C ; Humidity : 55 ±15%
- b. Visual Inspection : Distance between the panel and eyes is about 20~30cm, and the illumination is larger than 500Lux for product inspection.
- c. Electrical Characteristic : Distance between the panel and eyes is about 20~30cm, and the illumination is smaller than 300Lux, B/L illumination is between 2500~2800 cd/m² for product inspection.

(3) Sampling Method :

- a. Outline Size Specification : 5pcs/Lot , 0Ac/1Re.
- b. Electrical Inspection : Sampling of Inspection ANSI/ASQC Z1.4(AQL 0.65) Normal Inspection Level II, Single Sampling.
- c. Visual Inspection : Sampling of Inspection ANSI/ASQC Z1.4(AQL 1.0) Normal Inspection Level II, Single Sampling.

(4). LCM outgoing inspection criteria

Category	Item	Defect specification description	Method	SPEC	Criteria	Note	
Visual Inspection	FPC	bend	Visual	Scar bend are not allow			
		scratch		PAD area:	Not allow		
				Non PAD area: can not damage protection film			
	dirty 、 broken 、 lack parts 、 plate peeling		Not allow				
	B/L	Black spot, white spot, other defect	Magnifier	D ≤ 0.2mm		Ignore	Ignore the spot distance while bright dot is in spec.
				0.2mm < D ≤ 0.5mm		2	
				D > 0.5mm		0	
		W ≤ 0.03mm		L ignore	Ignore		
		0.03mm < W ≤ 0.08mm		L ≤ 4mm	4		
		W > 0.08mm		L > 4mm	0		
	Bezel	Dirty, oil sludge, corrosion	Visual	Not allow			
		scratch		W > 0.1mm	L > 10mm	3	
W ≤ 0.1mm				L ≤ 10mm	Ignore		
			The distance between two spot should be larger than 5mm				

SPECIFICATION

Category	Item	Defect specification description	Method	SPEC	Criteria	Note
Visual Inspection	Panel	surface crack	Visual	X ignore ; $Y \leq 0.4 \text{ mm}$; $Z \leq t$	Ignore	Fig.1
		Crack		$X \leq 2 \text{ mm}$; $0.4 \text{ mm} \leq Y \leq 1.3 \text{ mm}$; $Z \leq t$		
	Silicone Coating	Glue		Panel area: Glue over polarizer is not allowed		
		No foam and fringe		Around panel area :	Not allow	
		Coating		Not allow		
				IC area : Coating all IC		
	Polarizer	Stab 、 scratch 、 dent		Pad area : Coating all the circuits		
				Active area:	Not allow	Fig.1
		Polarizer bubble		Outside visual area:	Ignore	
				Active area:	Not allow	
		Concave 、 protruding		Outside visual area:		
				Active area : $D \leq 0.75 \text{ mm}$	Ignore	
	Shift	Outside visual area:		Ignore		
	Total line defect					4
Total dot defect					4	

SPECIFICATION

Category	Item	Defect specification description	Method	SPEC	Criteria	Note	
Electrical Inspection	Display	No display	Visual	Not allow			
	Line defect	Any line defect	Visual	Not allow			
	Mura	Mura/gap/rubbing	Visual	Limit sample	Can not worse than limit sample		
		White/black spot					
		Flicker 、 noise		Not allow			
	Bright dot	RGB bright dot 、 color filter scratch	Magnifier		$D \leq 1/2 \text{ Dot}$	Ignore	Ignore the spot distance while bright dot is in spec.
					$1/2 \text{ Dot} < D \leq 1\text{Dot}$	2	
		Active area		$D \leq 0.1\text{mm}$	Ignore		
				$0.1\text{mm} < D \leq 0.15\text{mm}$	2		
				$D > 0.15\text{mm}$	0		
		Outside visual area:		$D \leq 0.3\text{mm}$	Ignore		
				$0.3\text{mm} < D \leq 0.5\text{mm}$	1		
		$D > 0.5\text{mm}$	0				
		The distance between two BM hole should be larger than 5mm					
		Nearby bright dot			Not allow		
		Total bright dot				3	
	Dark dot	RGB dark dot	Magnifier		$D \leq 1 \text{ Dot}$	2	
					$1 \text{ Dot} \leq D \leq 2 \text{ Dot}$	1	
Nearby dark dot				$1 \text{ Dot} \leq D \leq 2 \text{ Dot}$	1Pair		
Total dark dot				2 nearby dark dot counted as 2 points	3		
Polarizer defect	Spot, line defect	Magnifier		$D \leq 0.15 \text{ mm}$	Ignore	Ignore the spot distance while bright dot is in spec.	
				$0.15\text{mm} < D \leq 0.25\text{mm}$	3		
				The distance between two spot should be larger than 5mm			
Total dot(dark +bright)					4	Include bright dot, dark dot, CF bright dot, BM hole, polarizer bright dot	
Distance	Distance between 2 bright dot 、 bright and dark dot 、 2 dark dot	check rulers		The distance between two spot should be larger than 5mm.			

11. GENERAL PRECAUTIONS

11.1. Handling

- (a) When the module is assembled, it should be attached to the system firmly. Be careful not to twist and bend the module.
- (b) Refrain from strong mechanical shock and / or any force to the module. In addition to damage, this may cause improper operation or damage to the module and back-light unit.
- (c) Note that polarizers are very fragile and could be easily damaged. Do not press or scratch the surface harder than a HB pencil lead.
- (d) Wipe off water droplets or oil immediately. If you leave the droplets for a long time, Staining and discoloration may occur.
- (e) If the surface of the polarizer is dirty, clean it using some absorbent cotton or soft cloth.
- (f) The desirable cleaners are water, Isopropyl Alcohol or Hexane.
- (g) If the liquid crystal material leaks from the panel, it should be kept away from the eyes or mouth. In case of contact with hands, legs or clothes, it must be washed away thoroughly with soap.
- (h) Use finger-stalls with soft gloves in order to keep display clean during the incoming inspection and assembly process.
- (i) Do not disassemble the module.
- (j) Protection film for polarizer on the module shall be slowly peeled off just before use so that the electrostatic charge can be minimized.

11.2. Storage

- (a) Do not leave the Panel in high temperature, and high humidity for a long time. It is highly recommended to store the module with temperature from 0 to 35°C and relative humidity of less than 70%.
- (b) Do not store the TFT-LCD module in direct sunlight.
- (c) The module shall be stored in a dark place. It is prohibited to apply sunlight or fluorescent light during the store.

11.3. Other

- (a) When in operations, do not connect; disconnect the module in the "Power on" condition.
- (b) The liquid crystal is deteriorated by ultraviolet; do not leave it in direct sunlight and strong ultraviolet ray for hours.
- (c) Avoid condensation of water. It may result in improper operation or disconnection of electrode.
- (d) Do not exceed the absolute maximum rating value. Otherwise the panel may be damaged.
- (e) If the panel displays the same pattern continuously for a long period of time, it can be the situation when the image "Stick" to the screen
- (f) The max temperature / continuous time of FPC soldering are 320°C / 5 seconds.

12. OUTLINE DIMENSION

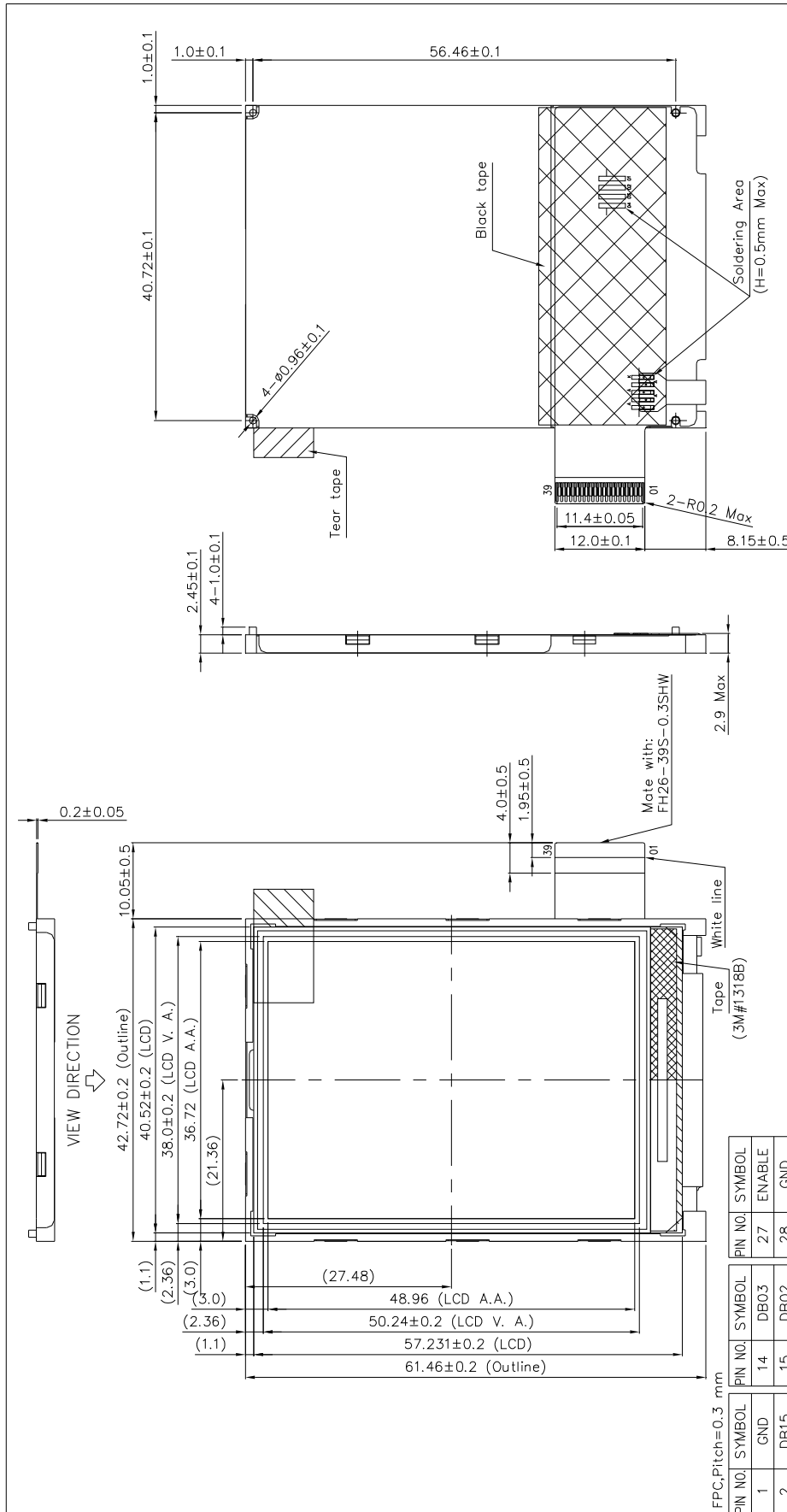

Notes:
1.Resolution : (240x3) x 320 Dots
2.Backlight : LED (White)
3.Driver IC: R6i505U or Compatible

GENERAL TOLERANCE LIST

DIMENSION	TOLERANCE
L ≤ 6	±0.25 (mm)
6 < L ≤ 18	±0.3 (mm)
18 < L ≤ 50	±0.4 (mm)
50 < L ≤ 125	±0.5 (mm)
125 < L	±0.6 (mm)
ANGLE	±1° (DEG)

南亞塑膠工業股份有限公司
NAN YA PLASTICS CORPORATION
製 品 圖
LVC46Z806YS

APPROVE	NAME	DATE	THIRD ANGLE P.
CHECK	Compos Chen	97.01.17	SCALE
DESIGN	Compos Chen	97.01.17	UNIT
DRAWN	Compos Chen	97.01.17	mm

REV. NO.	DESCRIPTION	DATE	DESIGN	CHECK	APPROVE

DWG NO. M806-D10A

FPC Pitch=0.3 mm

PIN NO.	SYMBOL	PIN NO.	SYMBOL	PIN NO.	SYMBOL
1	GND	14	DB03	27	ENABLE
2	DB15	15	DB02	28	GND
3	DB14	16	DB01	29	NC
4	DB13	17	DB00	30	NC
5	DB12	18	NC	31	NC
6	DB11	19	NC	32	NC
7	DB10	20	CS	33	VDD
8	DB09	21	SDI	34	VDD
9	DB08	22	SCL	35	LED1+
10	DB07	23	DOTCLK	36	LED2+
11	DB06	24	RESET	37	LED3+
12	DB05	25	HSYNC	38	LED4+
13	DB04	26	VSNC	39	LED-