

# NAN YA PLASTICS CORPORATION

SPECIFICATION OF  
LCD MODULE  
PRODUCT NO.: LCBHBTB61MS

SPEC. NO: LMB61-0C-0

CUSTOMER
APPROVED BY
DATE:

LCD DEPARTMENT  
ELECTRONIC MATERIALS DIVISION  
NAN YA PLASTICS CORPORATION  
201, TUNG HWA N. ROAD, TAIPEI  
TEL: 886-2-27122211 EXT. 5993~5995  
FAX: 886-2-27178253  
E-mail: lcdsales@npc.com.tw

EDITED ON : Mar. 03. 2006

Q.C. DEPT.	DESIGN MANAGER	DESIGN CHECK	DESIGNER
			W.R.HSU



# 1. MECHANICAL DATA

NO	ITEM	CONTENTS	UNIT
1	Product No.	LCBHBTB61MS	-
2	Module Size	168.0 (W) x 111.0 (H) x 7.4 (D)	mm
3	Dot Size	0.10 (W) x 0.34 (H)	mm
4	Dot Pitch	0.12 (W) x 0.36 (H)	mm
5	Number of Dots	320 x RGB (W) x 240 (H)	Dot
6	Duty	1/240	-
7	LCD Display Mode	FSTN, Color STN Module	-
8	Rear Polarizer	Color Transmissive Type	-
9	Viewing Direction	6	O'clock
10	Backlight	CCFL	-
11	Controller	Excluded	-
12	DC/DC Converter	Excluded	-
13	Touch Panel	Excluded	-
14	Weight	280 (Approx.)	g

Note :

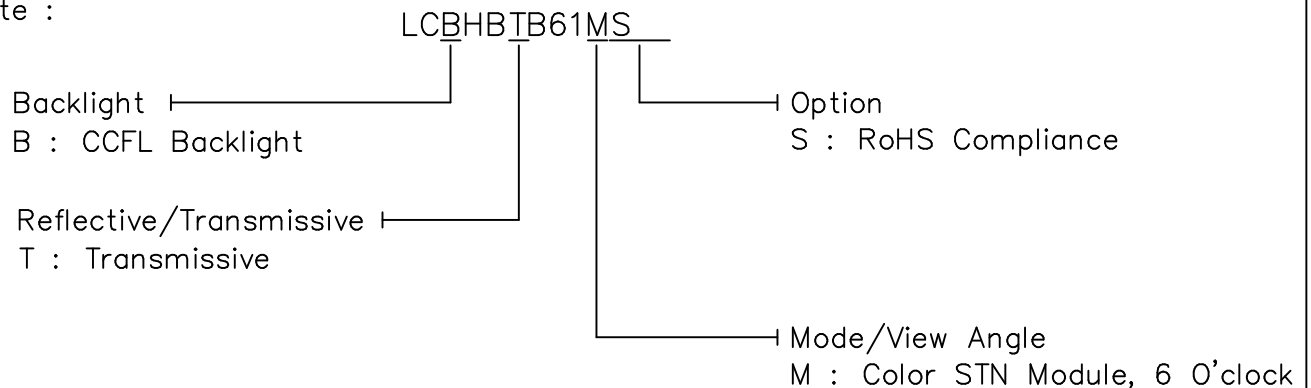

**RoHS Compliance.**

Nan Ya guarantees that this project doesn't include any materials (6 materials) or includes less than specified quantities which are regulated by RoHS Compliance.

## 2. ABSOLUTE MAXIMUM RATINGS

### (1) ELECTRICAL ABSOLUTE RATINGS

VSS=0V

	SYMBOL	MIN.	MAX.	UNIT	COMMENT
Power Supply for Logic	VDD-VSS	-0.3	5.5	V	
Input Voltage	VI	-0.3	VDD	V	
Static Electricity	-	-	-	-	Note 1

Note 1 LCM should be grounded during handling LCM.

### (2) ENVIRONMENTAL ABSOLUTE MAXIMUM RATINGS

ITEM	WIDE TEMP.			
	OPERATING		STORAGE	
	MIN.	MAX.	MIN.	MAX.
Ambient Temperature	-20	70	-40	80
Humidity (Without Condensation)	Note 2,4		Note 3,4	

Note 2  $T_a \leq 70^{\circ}\text{C}$  : 75%RH max

Note 3 Please refer to item of reliability test

Note 4 Background color will change slightly depending on ambient temperature.  
That phenomenon is reversible.

### 3. ELECTRICAL CHARACTERISTICS

#### 3-1. ELECTRICAL CHARACTERISTICS OF LCM

ITEM	SYMBOL	CONDITION	MIN.	TYP.	MAX.	UNIT	
Logic Circuit Power Supply	VDD-VSS	Ta= 25°C	4.5	5.0	5.5	V	
Logic Circuit Power Supply	VDD-VSS	Ta= 25°C	2.7	3.0	3.3	V	
Input Voltage	VIH	H level	0.8VDD	-	VDD	V	
	VIL	L level	0	-	0.2VDD		
Recommended LCD Driving Voltage	VLCD-VSS	Duty=1/240 VDD=3V/5V	-20°C	24.6	25.0	25.4	V
			0°C	23.2	23.6	24.0	
			25°C	22.2	22.6	23.0	
			50°C	21.1	21.5	21.9	
			70°C	20.5	20.9	21.3	
Supply Current for Logic	IDD	VDD-VSS = 5.0V VLCD-VSS = 22.6V Ta= 25°C	-	1	6	mA	
Supply Current for LCD	ILCD	PATTERN: □ ■ □ ■ □ ■ □ ■ ■ □ ■ □ ■ □ ■ □	-	10	20		
Supply Current for Logic	IDD	VDD-VSS = 3.0V VLCD-VSS = 22.6V Ta= 25°C	-	2	6	mA	
Supply Current for LCD	ILCD	PATTERN: □ ■ □ ■ □ ■ □ ■ ■ □ ■ □ ■ □ ■ □	-	10	20		
LCM	Surface Luminance	L	PATTERN: (Dots All On of White Color)	60	90	-	cd/m <sup>2</sup>
			PATTERN: (Dots All Off)	-	6	10	
Recommended Frame Frequency for Optimum Cocontrast	FLM	-	115	120	125	Hz	

### 3-2.ELECTRICAL CHARACTERISTICS OF BACKLIGHT

Used Lamp Rating

Temp.=25°C

ITEM	SYMBOL	MIN.	TYP.	MAX.	UNIT	REMARK
Lamp Voltage	$V_L$	-	296	-	Vrms	-
Lamp current	$I_L$	-	5	-	mArms	-
Lamp power consumption	$P_L$	-	1.48	-	W	(*1)
Starting voltage	$V_s$	-	-	460	Vrms	$T_a=25^\circ\text{C}$
		-	-	580	Vrms	$T_a=0^\circ\text{C}$
Lamp life time	$L_L$	-	20000	-	hrs	at $I_L = 5 \text{ mArms}$ $T_a=25^\circ\text{C}$ (*2)

(\*1) Power consumption excluded inverter loss .

(\*2) Lamp life time is defined as follows : The final brightness is at 50% of original brightness

### 3-3.ELECTRICAL CHARACTERISTICS OF RECOMMENDED INVERTER TDK CXA-L10L

#### 3-3-1 GENERAL SPECIFICATIONS

OPERATION TEMPERATURE : -10°C~60°C

STORAGE TEMPERATURE : -20°C~85°C

DIMENSION : 44.0(L)mm x 21.0(W)mm x MAX 18.0(H)mm

#### 3-3-2 PIN ASSIGNMENTS

INPUT (CN1) CONNECTOR :

OUTPUT (CN2) CONNECTOR :

NO.	FUNCTION
1	VIN
2	GND

NO.	FUNCTION
3	OUT1
4	OUT2
5	OUT GND

#### 3-3-3 RELATIONSHIP BETWEEN VIN & TUBE CURRENT

ITEM	SYMBOL	MIN.	TYP.	MAX.	UNIT	REMARK
Input Voltage	VIN	-	10.1	-	V	
Tube Current	IL	-	5	-	mA	

## 4. OPTICAL CHARACTERISTICS

### 4-1. Optical Char. of Wide Temp. Mode

AT V<sub>OP</sub>

ITEM MODE		Cr(Contrast Ratio)										$\theta$ (Viewing Angle)		$\theta$ (Viewing Angle)	
		-20°C		0°C		25°C		50°C		70°C		25°C		25°C	
		MIN.	TYP.	MIN.	TYP.	MIN.	TYP.	MIN.	TYP.	MIN.	TYP.	MIN.	TYP.	MIN.	TYP.
T	M	12	18	14	20	17	25	3.5	5	1.4	2	-	F: 45 R: 40	-	L: 35 R: 35
NOTE		NOTE 6										NOTE 5			

NOTE :

T : Transmissive

V : Color STN Module, 6 O'clock

AT  $\phi=0^\circ$   $\theta=0^\circ$

ITEM	SYMBOL	CONDITION	MIN.	TYP.	MAX.	UNIT	NOTE
Response Time (rise)	Tr	-20°C	2300	2900	4300	ms	NOTE 2
		0°C	640	800	1200		
		25°C	240	300	450		
		50°C	80	100	150		
		70°C	45	55	80		
Response Time (fall)	Tf	-20°C	1500	1800	2700	ms	NOTE 2
		0°C	360	450	670		
		25°C	80	100	150		
		50°C	48	60	90		
		70°C	32	40	60		

4-2. Color of CIE Coordinate

Ta = 25°C

ITEM		SYMBOL	CONDITION	VALUE	NOTE
Color of CIE Coordinate	Red	X	$\phi=0^\circ, \theta=0^\circ$	0.55	Note*
		y		0.33	
	Green	X	$\phi=0^\circ, \theta=0^\circ$	0.30	
		y		0.55	
	Blue	X	$\phi=0^\circ, \theta=0^\circ$	0.16	
		y		0.11	
	White	X	$\phi=0^\circ, \theta=0^\circ$	0.30	
		y		0.31	

Note\* Measuring at position 3 on Fig.1  
 CIE chromaticity diagram

Tolerance :  $\pm 0.05$

Fig.1

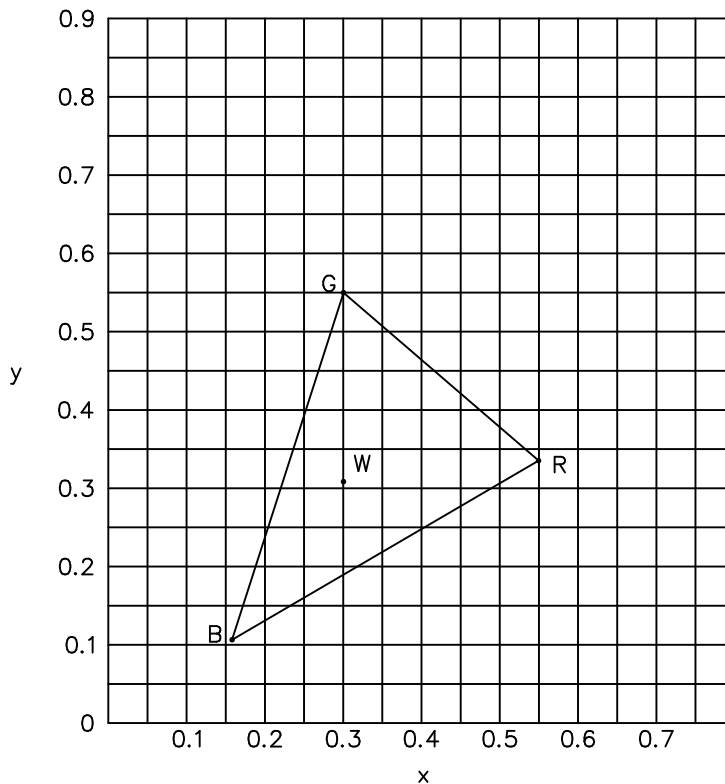

(NOTE 1)

Definition of Operation Voltage(Vop)

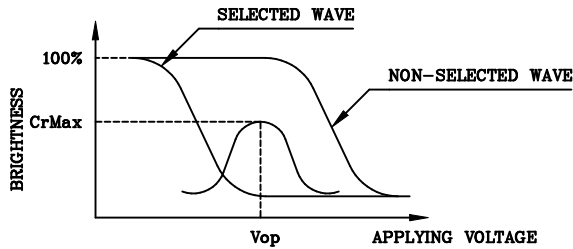

(positive type)

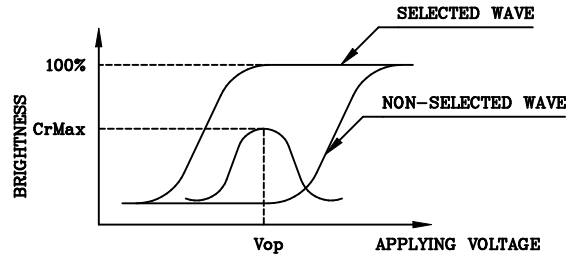

(negative type)

\*Conditions

Viewing Angle : 0  
Frame Frequency : 120Hz  
Applying Waveform : 1/N duty 1/a bias

(NOTE 2)

Definition of Response Time(Tr,Tf)

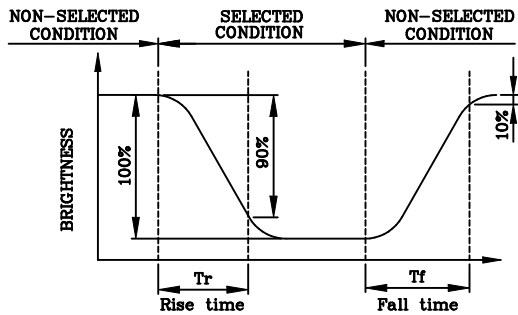

(positive type)

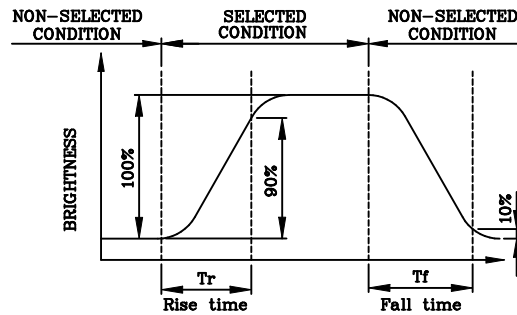

(negative type)

\*Conditions

Operating Voltage : Vop  
Viewing Angle (θ,φ) : (0,0)  
Frame Frequency : 120Hz  
Applying Waveform : 1/N duty 1/a bias

(NOTE 3)

Description of Measuring Equipment and Driving Waveforms

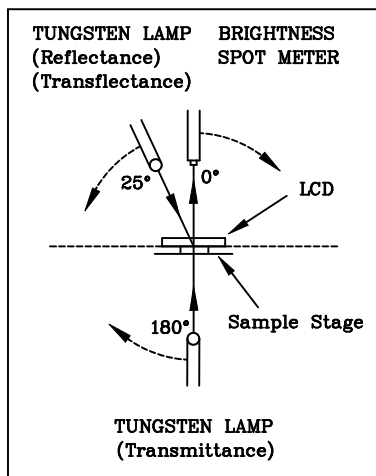

CONST.  
TEMP.  
CHAMBER

Multiplex Driving ( 1/N duty 1/a bias )

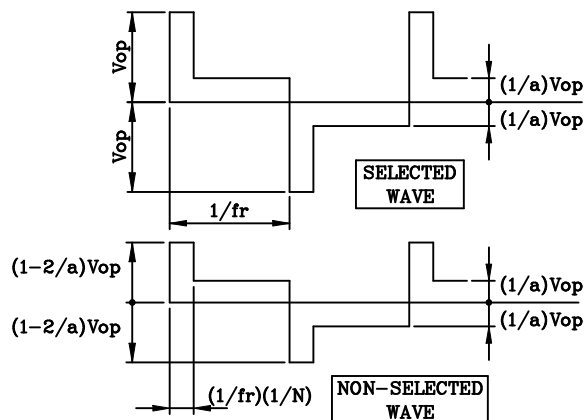

(NOTE 4)

Definition of Viewing Direction

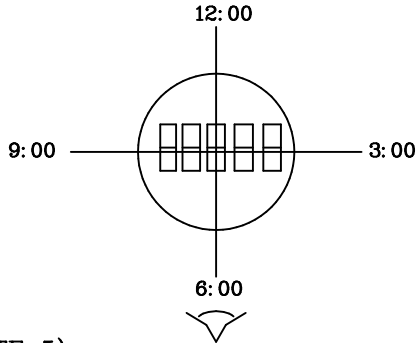

(NOTE 5)

Definition of Viewing Angle

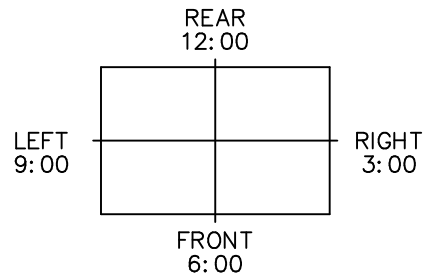
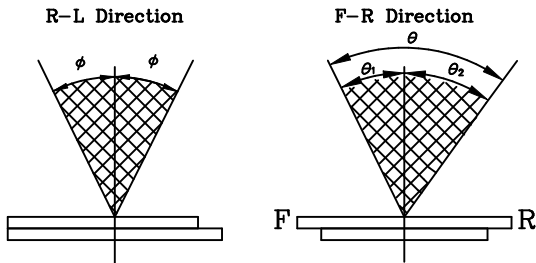

\*For This Product  
 The Viewing Direction Is 6 O'clock  
 So  $\theta_1 > \theta_2$

$$\theta = \theta_1 + \theta_2$$

\*Conditions

Operating Voltage :  $V_{op}$   
 Frame Frequency : 120Hz  
 Applying Waveform : 1/N duty 1/a bias  
 Contrast Ratio : larger than 2

(NOTE 6)

Definition of Contrast Ratio (Cr)

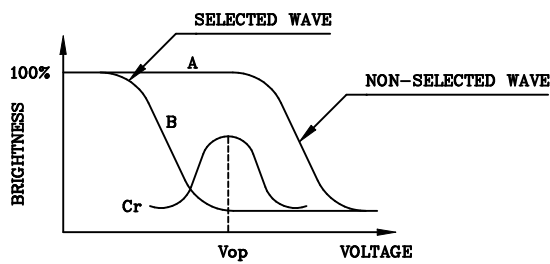

(positive type)

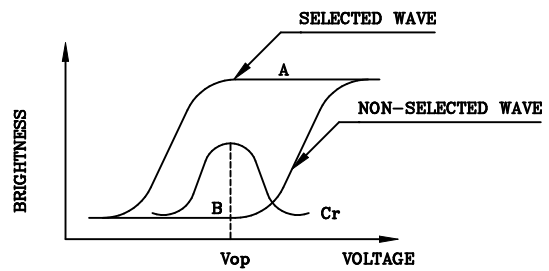

(negative type)

$$\text{Contrast Ratio : } Cr = A/B$$

\*Conditions

Viewing Angle : 0  
 Frame Frequency : 120Hz  
 Applying Waveform : 1/N duty 1/a bias

## 5. BLOCK DIAGRAM

LCD

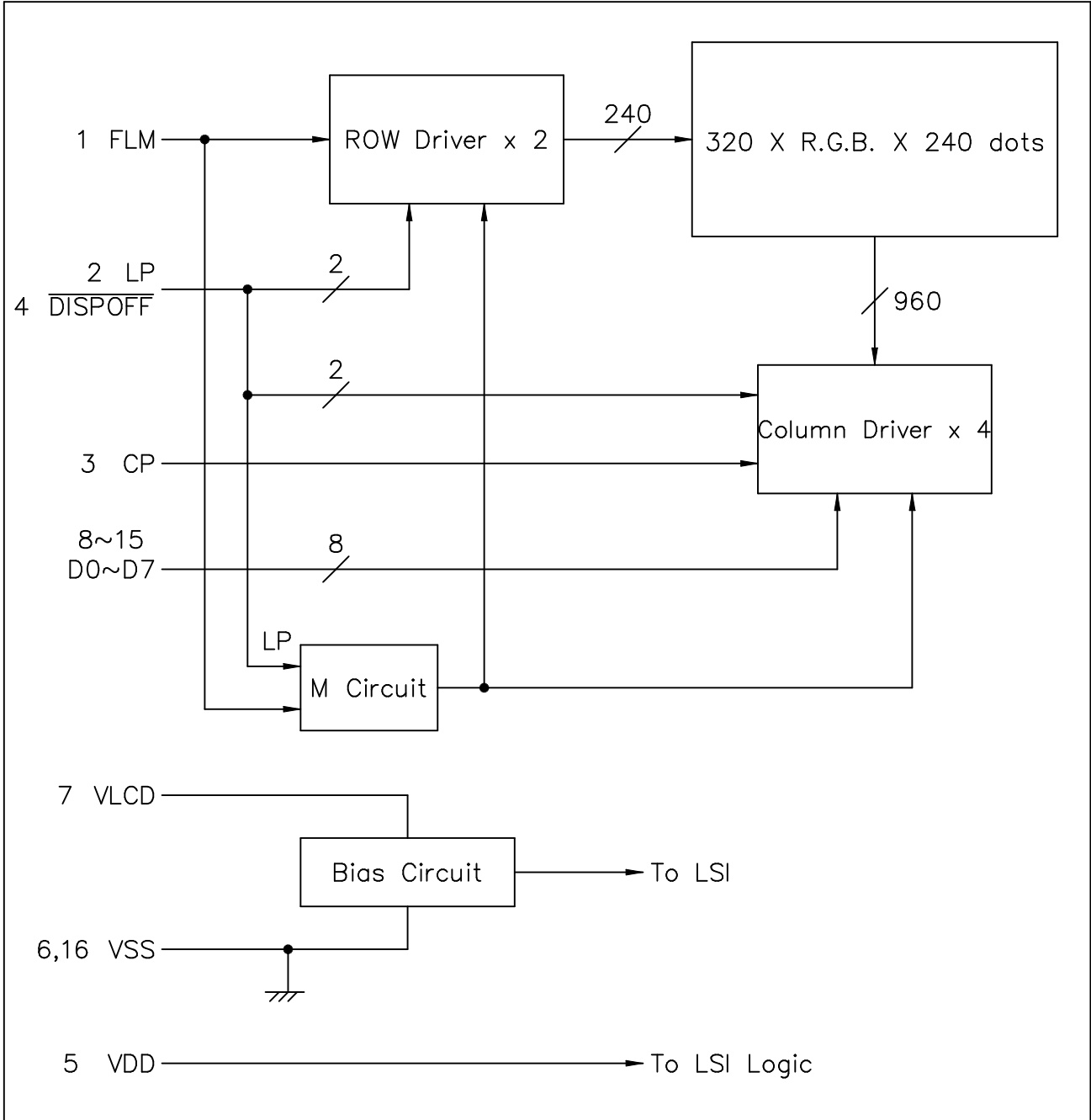

CCFL

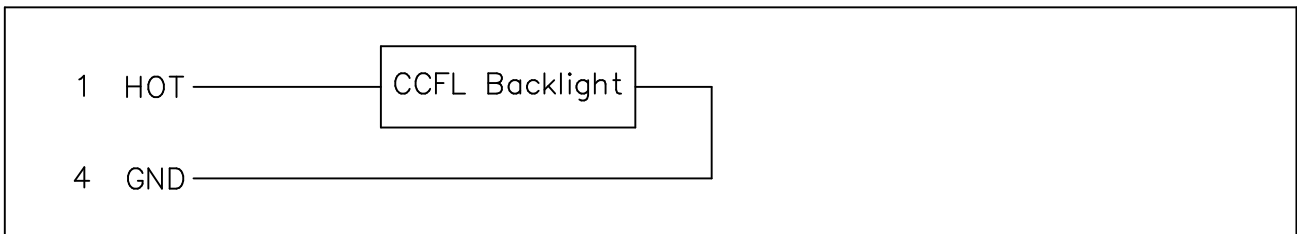

## 6. INTERNAL PIN CONNECTION

### LCD

Pin No.	Symbol	Level	Function
1	FLM	H/L	First Line Marker
2	LP	H→L	Data Latch Signal
3	CP	H→L	Clock Signal for Shifting Data
4	$\overline{\text{DISPOFF}}$	H/L	Display Control Signal, H :Display on L :Display off
5	VDD	—	Power Supply for Logic
6	VSS	—	Power Supply (0V,GND)
7	VLCD	—	Power Supply for LCD Drive
8	D0	H/L	Display Data
9	D1	H/L	Display Data
10	D2	H/L	Display Data
11	D3	H/L	Display Data
12	D4	H/L	Display Data
13	D5	H/L	Display Data
14	D6	H/L	Display Data
15	D7	H/L	Display Data
16	VSS	—	Power Supply (0V,GND)

### CCFL

Pin No.	Symbol	Level	Function
1	HOT	—	Power Supply for CCFL(HOT)
2	NC	—	Non-connection
3	NC	—	Non-connection
4	GND	—	Power Supply for CCFL(GND)

LCD INTERFACE CABLE :

FFC,N16,Pitch 1.0 mm (Thickness = 0.3 mm)

CORRESPONDABLE LCD CONNECTOR :

MOLEX 52207-1685 or COMPATIBLE

CCFL CONNECTOR :

M63M83-04 (MITSUMI)

CORRESPONDABLE CCFL CONNECTOR :

M60-04-30-134P or M60-04-30-114P or M61M73-04 (MITSUMI)

## 7. POWER SUPPLY

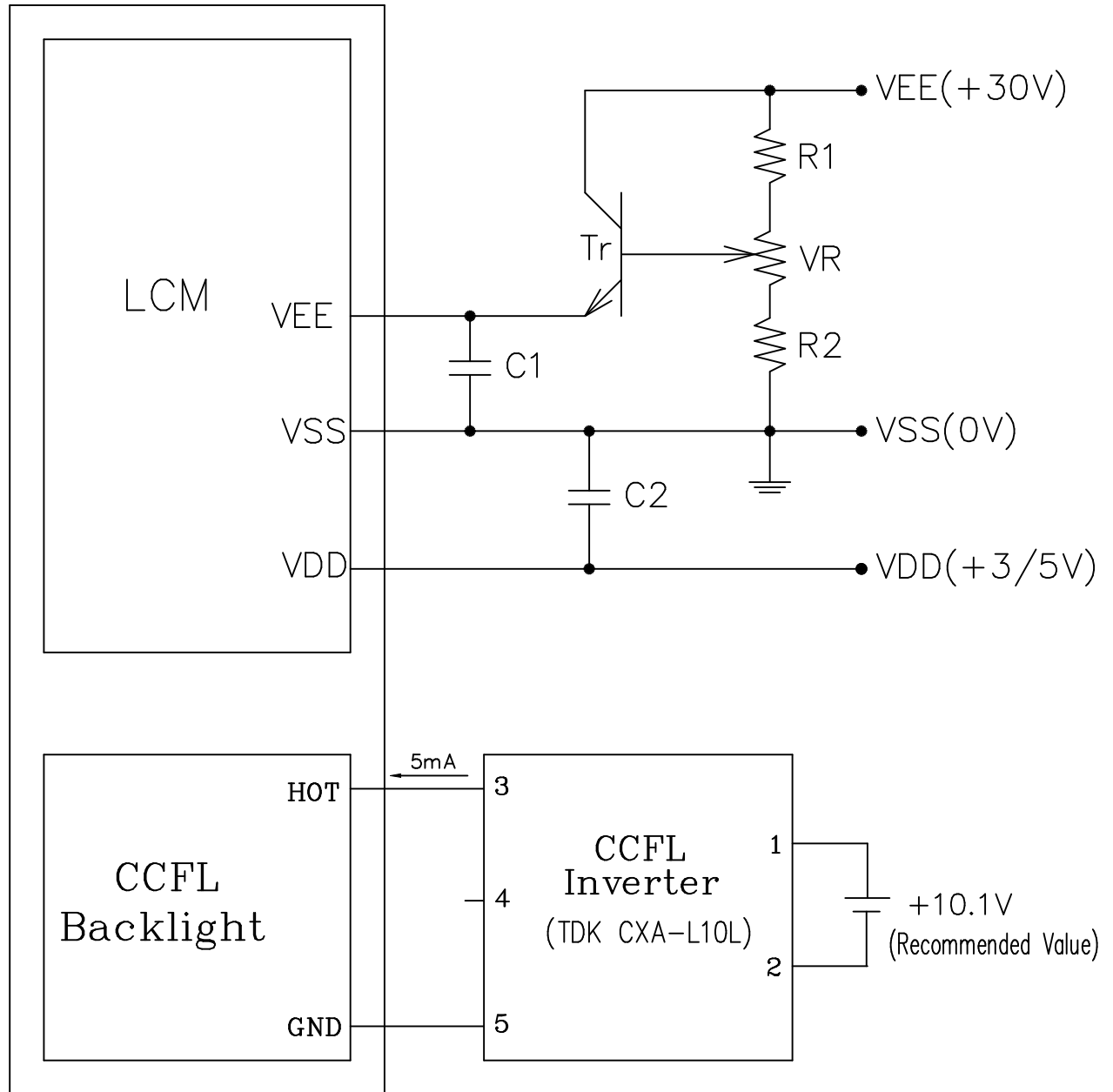

$$1. R1 + R2 + VR = 10 \sim 20K \Omega$$

$$C1, C2 = 10 \mu F$$

## 8. TIMING CHARACTERISTICS

### 8-1. INTERFACE TIMING

VDD=3.3V ± 10%

Parameter	SYMBOL	MIN.	MAX.	UNIT
CLOCK PULSE CYCLE TIME	$t_{wck}$	66	—	ns
CLOCK PULSE HIGH LEVEL WIDTH	$t_{wckH}$	23	—	ns
CLOCK PULSE LOW LEVEL WIDTH	$t_{wckL}$	23	—	ns
LATCH PULSE HIGH LEVEL WIDTH	$t_{wLPH}$	30	—	ns
CP→LP RISE TIME	$t_{LD}$	10	—	ns
CP→LP FALL TIME	$t_{SL}$	30	—	ns
LP→CP RISE TIME	$t_{LS}$	30	—	ns
LP→CP FALL TIME	$t_{LH}$	30	—	ns
CLOCK PULSE RISE/FALL TIME	$t_r, t_f$	—	30	ns
DATA SETUP TIME	$t_{DS}$	10	—	ns
DATA HOLD TIME	$t_{DH}$	25	—	ns
DISPOFF LOW LEVEL WIDTH	$t_{WDL}$	1.2	—	μs
DISPOFF CANCELLATION TIME	$t_{SD}$	100	—	ns

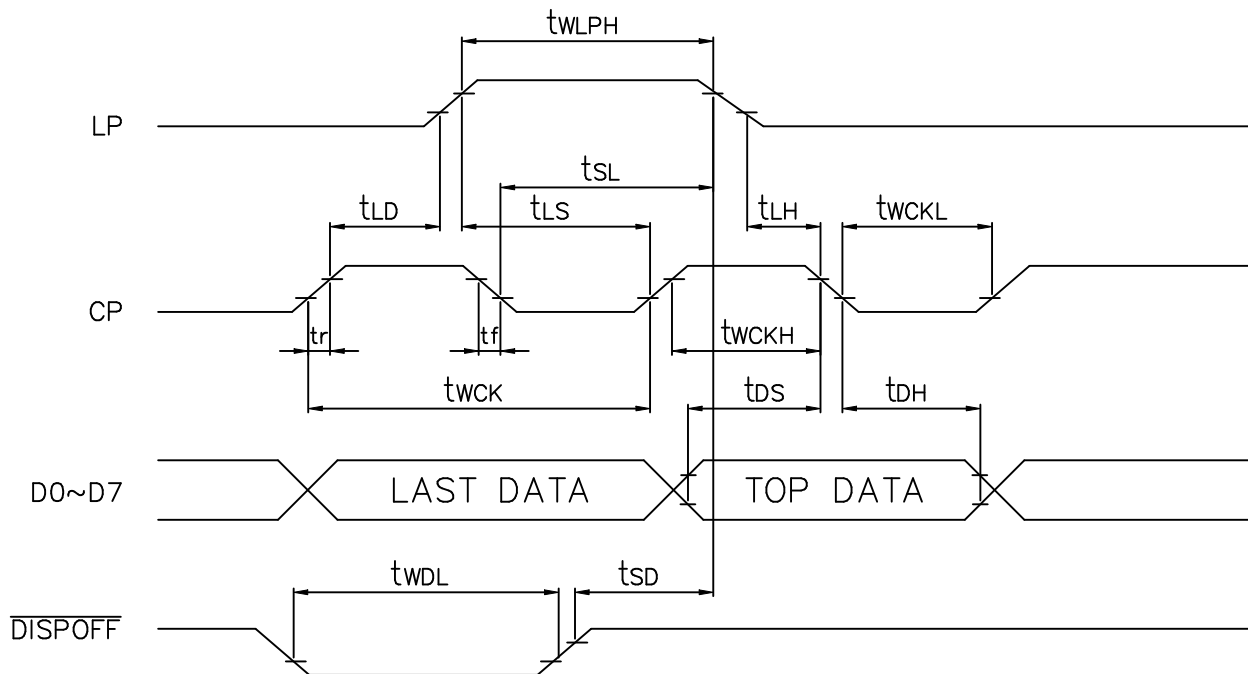

## 8-2. TIMING CHART OF INPUT SIGNAL

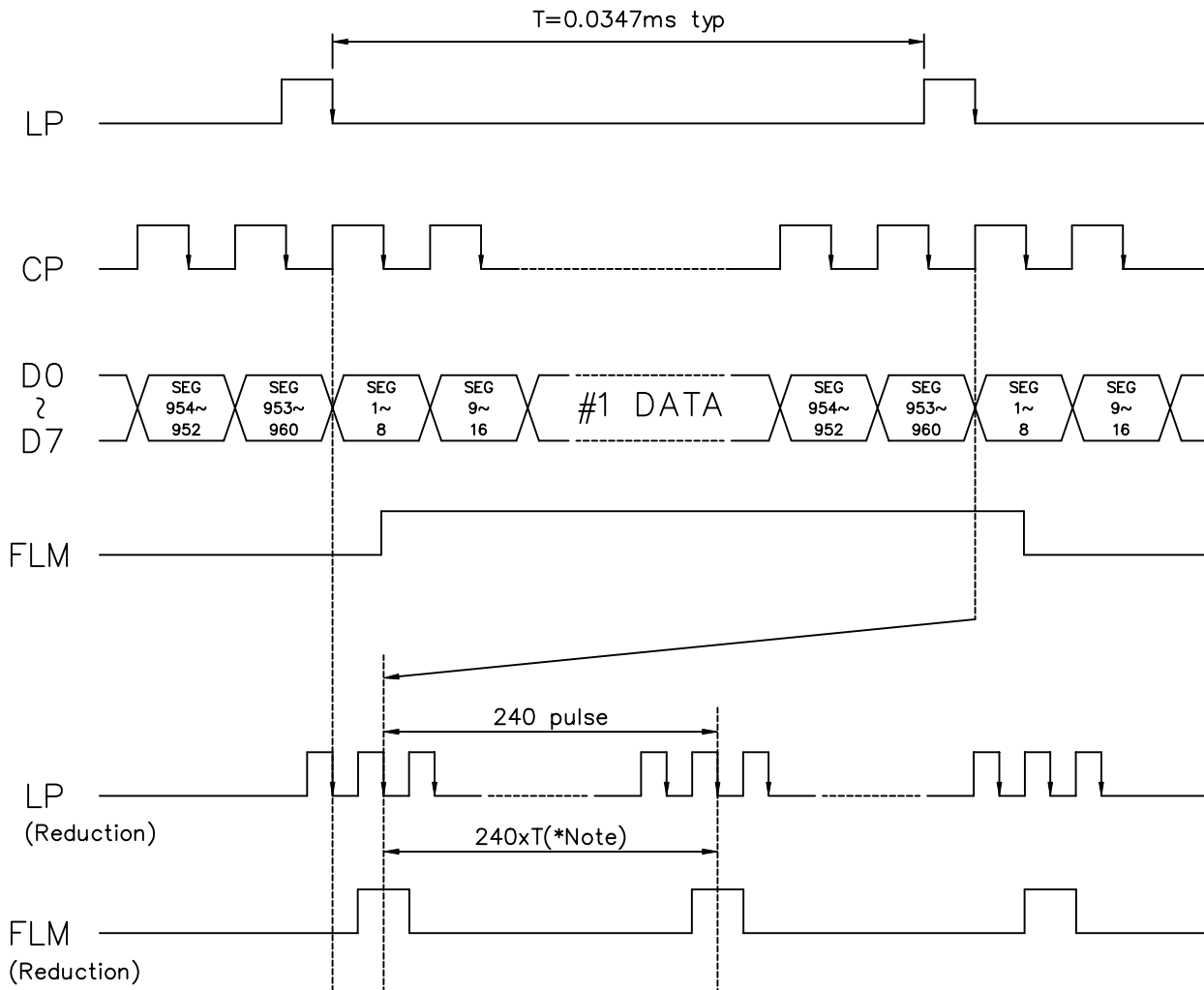

\*Note :

If you have problem of display quality , you may modify the LP pulse to improve .

Method : 1. Increase one pulse of LP.

2. Check the display quality.

3. If display quality N.G. , redo item 1.

4. If you try many value (ex: 240~260) , you can't get the best quality . The display error may cause by others.

### 8-3. POWER ON/OFF TIMING

#### ON SEQUENCE

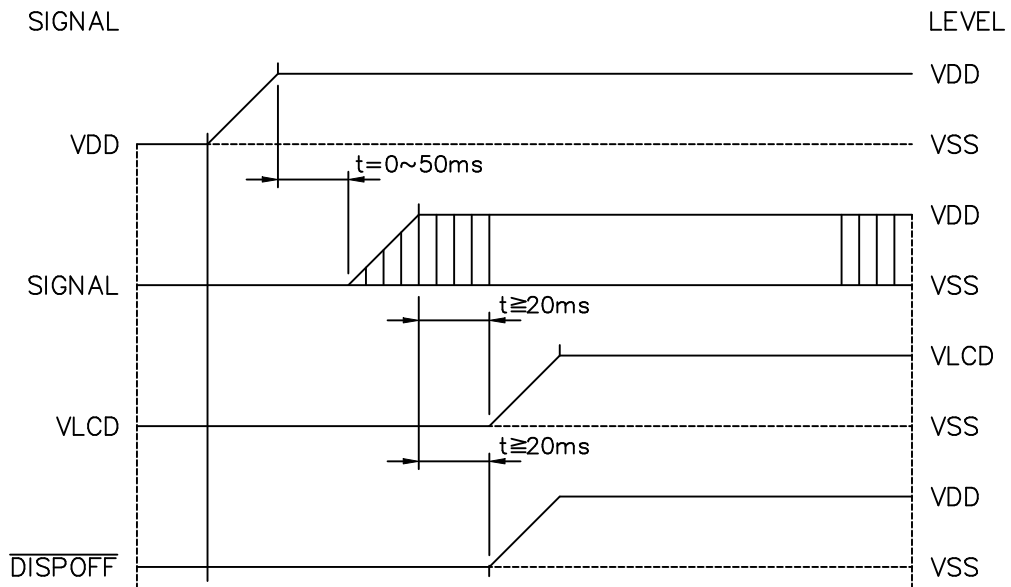

#### OFF SEQUENCE

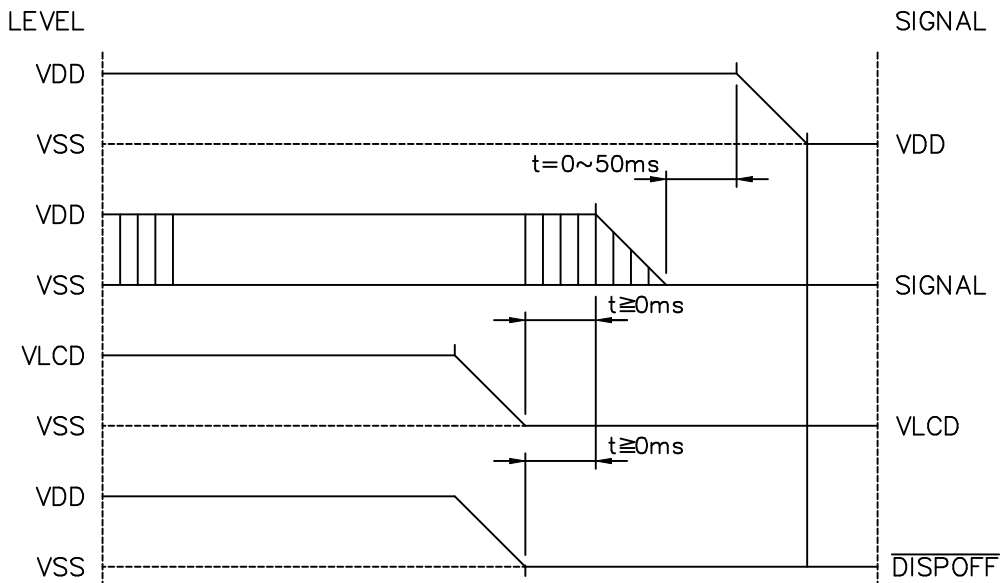

Please maintain the above sequence when turning on and off the power supply of the module. If  $\overline{\text{DISPOFF}}$  is supplied to the module while internal alternate signal for LCD driving(M) is unstable, DC component will be supplied to the LCD panel. This may cause damage the LCD module.

### 8-4.DISPLAY PATTERN

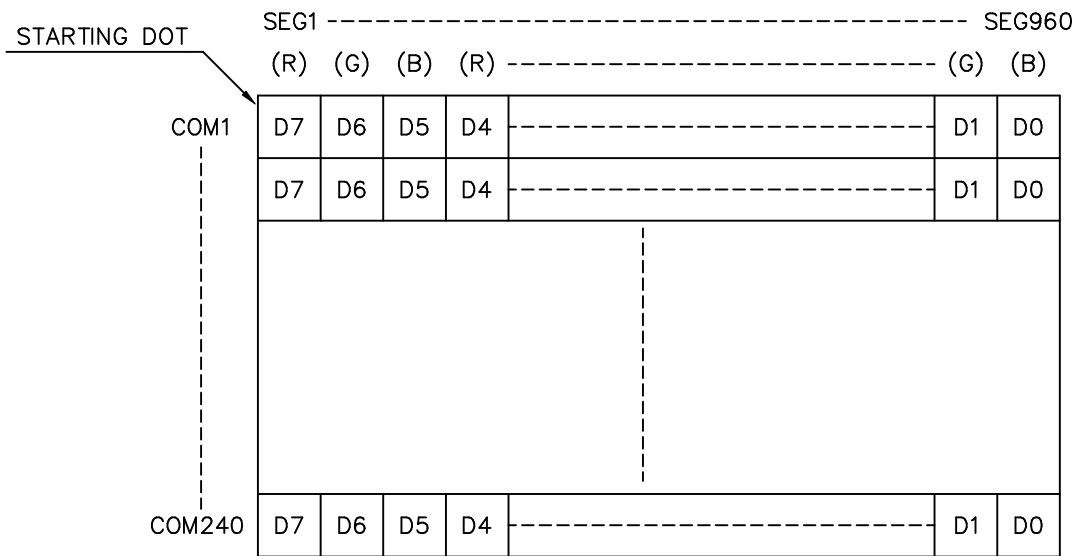

D0~D7 are 8 bits transmitted data, where D0 is LSB and D7 is MSB.

## 9. RELIABILITY TEST

### WIDE TEMPERATURE RELIABILITY TEST

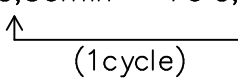
NO	ITEM	CONDITION			STANDARD	NOTE
1	High Temp. Storage	80°C	120Hrs		Appearance without defect	
2	Low Temp. Storage	-40°C	120Hrs		Appearance without defect	
3	High Temp. & High Humi. Storage	60°C 90%RH	120Hrs		Appearance without defect	
4	High Temp. Operating Display	70°C	120Hrs		Appearance without defect	
5	Low Temp. Operating Display	-20°C	120Hrs		Appearance without defect	
6	Thermal Shock	-20°C, 30min → 70°C, 30min  (1cycle)			Appearance without defect	10 cycles

Inspection Provision

1. Purpose

The NAN YA inspection provision provides outgoing inspection provision and its expected quality level based on our outgoing inspection of NAN YA LCD produces.

2. Applicable Scope

The NAN YA inspection provision is applicable to the arrangement in regard to outgoing inspection and quality assurance after outgoing.

3. Technical Terms

3-1 NAN YA Technical Terms

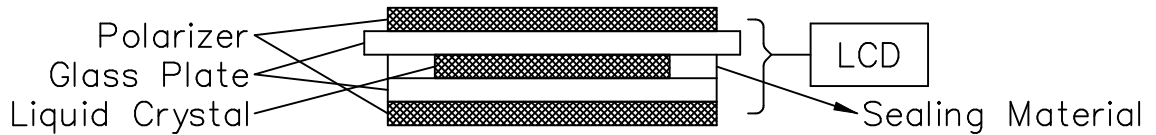

4. Outgoing Inspection

4-1 Inspection Method

MIL-STD-105E Level II Regular inspection

4-2 Inspection Standard

	Item		AQL(%)	Remarks
Major Defect	Dots	Opens Shorts Erroneous operation	0.4	faults which substantially lower the practicality and the initial purpose difficult to achieve.
	Solder appearance	Shorts Loose		
	Cracks	Display surface cracks		

	Dimensions	External from Dimensions	0.4	
Minor Defect	Inside the glass	Black spots	0.65	faults which appear to pose almost no obstacle to the practicality, effective use, and operation.
	Polarizing plate	Scratches, foreign Matter, air bubbles, and peeling		
	Dots	Pinhole, deformation		
	Color tone	Color unevenness		
	Solder appearance	Cold solder Solder projections		

4-3 Inspection Provisions  
\*Viewing Area Definition

Fig. 1

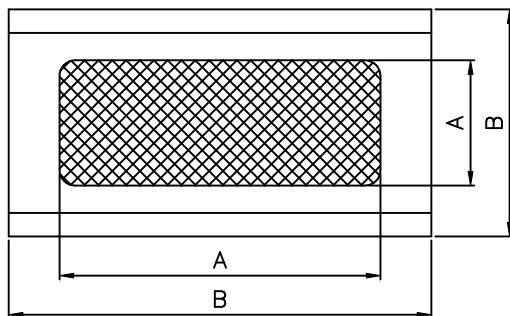

A : Zone Viewing Area  
B : Zone Glass Plate Outline

\*Inspection place to be 500 to 1000 lux illuminance uniformly without glaring.  
The distance between luminous source(daylight fluorescent lamp and cool white fluorescent lamp) and sample to be 30cm to 50cm.

\*Test and measurement are performed under the following conditions, unless otherwise specified.

Temperature            20± 15°C  
Humidity                65± 20%R.H.  
Pressure                860~1060hPa(mmbar)

In case of doubtful judgment, it is performed under the following conditions.

Temperature            20± 2°C  
Humidity                65± 5%R.H.  
Pressure                860~1060hPa(mmbar)

5.Specification for quality check  
5-1 Electrical characteristics

NO.	Item	Criterion
1	Non operational	Fail
2	Miss operating	Fail
3	Missing dot	Fail
4	Contrast irregular	Fail
5	Response time	Within Specified value
6	Backlight turn on/off	Within Specified value

5-2 External Appearance Defect

NO.	Item	Criterion																							
1	Black spots, foreign matter, and white spots (Including light leakage due to pinholes of polarizing plates, etc.)	<p>(1)-1-Spots</p> <table border="1" data-bbox="703 490 1398 819"> <thead> <tr> <th>Average Diameter(mm):D</th> <th>Number of pieces permitted</th> <th>Minimum Space</th> </tr> </thead> <tbody> <tr> <td><math>D \leq 0.2</math></td> <td>Ignore</td> <td>-</td> </tr> <tr> <td><math>0.2 &lt; D \leq 0.3</math></td> <td>5</td> <td>10mm</td> </tr> <tr> <td><math>0.3 &lt; D \leq 0.4</math></td> <td>2</td> <td>30mm</td> </tr> <tr> <td><math>0.4 &lt; D</math></td> <td>0</td> <td></td> </tr> </tbody> </table> <p>Number of total pieces is set to within 5 pieces.</p> <p>Note that when there are 2 pieces or more, they are not to be concentrated. Set as: Average diameter = (Long diameter + Short diameter)/2</p> <p>(1)-2-Blurred Spots(At lighting condition)</p> <table border="1" data-bbox="703 1234 1334 1469"> <thead> <tr> <th>Average Diameter(mm):D</th> <th>Number of pieces permitted</th> </tr> </thead> <tbody> <tr> <td><math>D \leq 0.3</math></td> <td>Ignore</td> </tr> <tr> <td><math>0.3 &lt; D \leq 0.75</math></td> <td>5</td> </tr> <tr> <td><math>0.75 &lt; D</math></td> <td>0</td> </tr> </tbody> </table> <p>Number of total pieces is set to within 5 pieces.</p> <p>Note that when there are 2 pieces or more, they are not to be concentrated. Set as: Average diameter = (Long diameter + Short diameter)/2</p>	Average Diameter(mm):D	Number of pieces permitted	Minimum Space	$D \leq 0.2$	Ignore	-	$0.2 < D \leq 0.3$	5	10mm	$0.3 < D \leq 0.4$	2	30mm	$0.4 < D$	0		Average Diameter(mm):D	Number of pieces permitted	$D \leq 0.3$	Ignore	$0.3 < D \leq 0.75$	5	$0.75 < D$	0
Average Diameter(mm):D	Number of pieces permitted	Minimum Space																							
$D \leq 0.2$	Ignore	-																							
$0.2 < D \leq 0.3$	5	10mm																							
$0.3 < D \leq 0.4$	2	30mm																							
$0.4 < D$	0																								
Average Diameter(mm):D	Number of pieces permitted																								
$D \leq 0.3$	Ignore																								
$0.3 < D \leq 0.75$	5																								
$0.75 < D$	0																								

1	Line	<p>(1)-1-Lines</p> <table border="1" data-bbox="703 443 1431 721"> <thead> <tr> <th>Width(mm): W</th> <th>Length(mm): L</th> <th>Number of pieces permitted</th> </tr> </thead> <tbody> <tr> <td><math>W \leq 0.03</math></td> <td>Ignore</td> <td>Ignore</td> </tr> <tr> <td><math>0.03 &lt; W \leq 0.08</math></td> <td><math>L \leq 4</math></td> <td>2</td> </tr> <tr> <td><math>0.08 &lt; W \leq 0.1</math></td> <td><math>L \leq 1</math></td> <td>1</td> </tr> </tbody> </table> <p>Object exceeding 0.1mm follow the standards of the spots form. Note that when there are 2 pieces or more, they are not to be concentrated.</p> <p>(1)-2-Blurred Lines(At lighting condition)</p> <table border="1" data-bbox="703 1021 1431 1299"> <thead> <tr> <th>Width(mm): W</th> <th>Length(mm): L</th> <th>Number of pieces permitted</th> </tr> </thead> <tbody> <tr> <td><math>W \leq 0.03</math></td> <td>Ignore</td> <td>Ignore</td> </tr> <tr> <td><math>0.03 &lt; W \leq 0.08</math></td> <td><math>L \leq 3</math></td> <td>6</td> </tr> <tr> <td><math>0.08 &lt; W</math></td> <td><math>3 &lt; L</math></td> <td>None</td> </tr> </tbody> </table> <p>Object exceeding 0.1mm follow the standards of the spots form. Note that when there are 2 pieces or more, they are not to be concentrated.</p>	Width(mm): W	Length(mm): L	Number of pieces permitted	$W \leq 0.03$	Ignore	Ignore	$0.03 < W \leq 0.08$	$L \leq 4$	2	$0.08 < W \leq 0.1$	$L \leq 1$	1	Width(mm): W	Length(mm): L	Number of pieces permitted	$W \leq 0.03$	Ignore	Ignore	$0.03 < W \leq 0.08$	$L \leq 3$	6	$0.08 < W$	$3 < L$	None
Width(mm): W	Length(mm): L	Number of pieces permitted																								
$W \leq 0.03$	Ignore	Ignore																								
$0.03 < W \leq 0.08$	$L \leq 4$	2																								
$0.08 < W \leq 0.1$	$L \leq 1$	1																								
Width(mm): W	Length(mm): L	Number of pieces permitted																								
$W \leq 0.03$	Ignore	Ignore																								
$0.03 < W \leq 0.08$	$L \leq 3$	6																								
$0.08 < W$	$3 < L$	None																								
2	Scratches(Glass, reflection plates, and polarizing plates)	In accordance with black spots. (At non lighting condition)																								
3	Color irregular	Not remarkable color irregular.																								

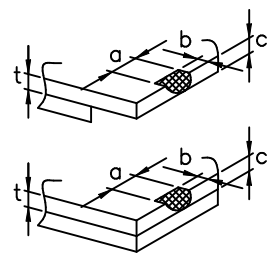
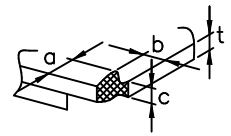
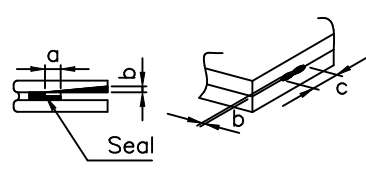
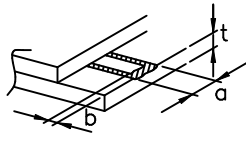
4	Air bubbles polarizing plates, and reflection plates	<table border="1" data-bbox="702 392 1204 683"> <tr> <td data-bbox="702 392 954 537">Average Diameter (mm): D</td> <td data-bbox="954 392 1204 537">Number of pieces permitted</td> <td data-bbox="1204 392 1450 683" rowspan="2">Average diameter = (Long diameter + Short diameter)/2</td> </tr> <tr> <td data-bbox="702 537 954 683">D ≤ 0.3 0.3 &lt; D</td> <td data-bbox="954 537 1204 683">Ignore 0</td> </tr> </table> <p data-bbox="702 694 1450 772">Note that when there are 4 pieces or more, they are not to be concentrated.</p>		Average Diameter (mm): D	Number of pieces permitted	Average diameter = (Long diameter + Short diameter)/2	D ≤ 0.3 0.3 < D	Ignore 0
Average Diameter (mm): D	Number of pieces permitted	Average diameter = (Long diameter + Short diameter)/2						
D ≤ 0.3 0.3 < D	Ignore 0							
5	Cracks	<p data-bbox="654 784 1045 840">(1) General crack</p> 	<p data-bbox="1045 784 1450 840"><math>a \leq 5</math></p> <p data-bbox="1045 840 1450 884"><math>b \leq 2</math></p> <p data-bbox="1045 884 1450 929"><math>c \leq t</math></p> <p data-bbox="1045 929 1450 1164">Where, a and b are ignored when less than or equal to 0.5 The numbers of pieces are set at up to 5 pieces.</p>					
		<p data-bbox="654 1164 1045 1220">(2) Corner crack</p> 	<p data-bbox="1045 1164 1450 1220"><math>a \leq 2.5</math></p> <p data-bbox="1045 1220 1450 1265"><math>b \leq 2.5</math></p> <p data-bbox="1045 1265 1450 1310"><math>c \leq t</math></p> <p data-bbox="1045 1310 1450 1355"><math>a + b \leq 4</math></p>					
		<p data-bbox="654 1355 1045 1411">(3) Seal portion crack</p> 	<p data-bbox="1045 1355 1450 1400"><math>a \leq</math> The seal width <math>\times 1/3</math></p> <p data-bbox="1045 1400 1450 1444"><math>b \leq t \times 2/3</math></p> <p data-bbox="1045 1444 1450 1489"><math>c \leq 5</math></p> <p data-bbox="1045 1489 1450 1624">The numbers of pieces are set at up to 5 pieces.</p>					
		<p data-bbox="654 1624 1045 1680">(4) ITO Pin crack</p> 	<p data-bbox="1045 1624 1450 1668"><math>a \leq 5</math></p> <p data-bbox="1045 1668 1450 1713"><math>b \leq 1/3</math> pin length</p> <p data-bbox="1045 1713 1450 1758"><math>c \leq t</math></p>					
		<p data-bbox="654 1848 1045 1904">(5) Progressive cracks</p>	<p data-bbox="1045 1848 1450 1946">All taken to be unacceptable.</p>					

6	Outer dimensions	Should be within the tolerance.
7	Newton ring(touch panel)	Orbicular of interference fringes is not allowed in the optimum contrast within the active area under viewing angle.
8	Soldering	Should be no defective soldering such as shorting, loose terminal cold solder, peeling of printed circuit board pattern, improper mounting position, etc.

5-3 Dot Appearance Defect

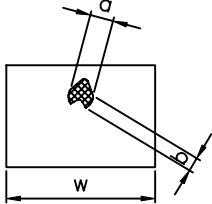
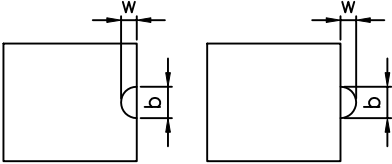
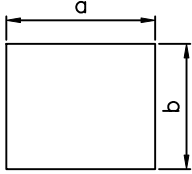
NO.	Item	Criteria
1	Pinhole	 <p>Dot display a and b are each <math>\leq 0.2\text{mm}</math> The overall total is taken be with in 10 units. Note that they are not to be concentrated.</p>
2	Missing	 <p>Dot display a and b are each <math>\leq 0.2\text{mm}</math> The overall total is taken to be with in 10 units.</p>
3	Thick and thin display	 <p>Taken to be within <math>\pm 1.5\%</math> of display character width(a) and height(b).</p>

NOTICE:

- SAFETY

- 1.If the LCD panel breaks, be careful not to get the liquid crystal to touch your skin.
- 2.If the liquid crystal touches your skin or clothes, please wash it off immediately by using soap and water.

- HANDLING

- 1.Avoid static electricity which can damage the CMOS LSI.
- 2.Do not remove the panel or frame from the module.
- 3.The polarizing plate of the display is very fragile. So, please handle it very carefully.
- 4.Do not wipe the polarizing plate with a dry cloth, as it may easily scratch the surface of plate.
- 5.Do not use ketonics solvent & Aromatic solvent. Use a soft cloth soaked with a cleaning naphtha solvent.

- STORAGE

- 1.Store the panel or module in a dark place where the temperature is  $25^{\circ}\text{C}\pm 5^{\circ}\text{C}$  and the humidity is below 65% RH.
- 2.Do not place the module near organics solvents or corrosive gases.
- 3.Do not crush, shake, or jolt the module.

- TERMS OF WARRANT

- 1.Acceptance inspection period  
The period is within one month after the arrival of contracted commodity at the buyer's factory site.
- 2.Applicable warrant period  
The period is within twelve months since the date of shipping out under normal using and storage conditions.

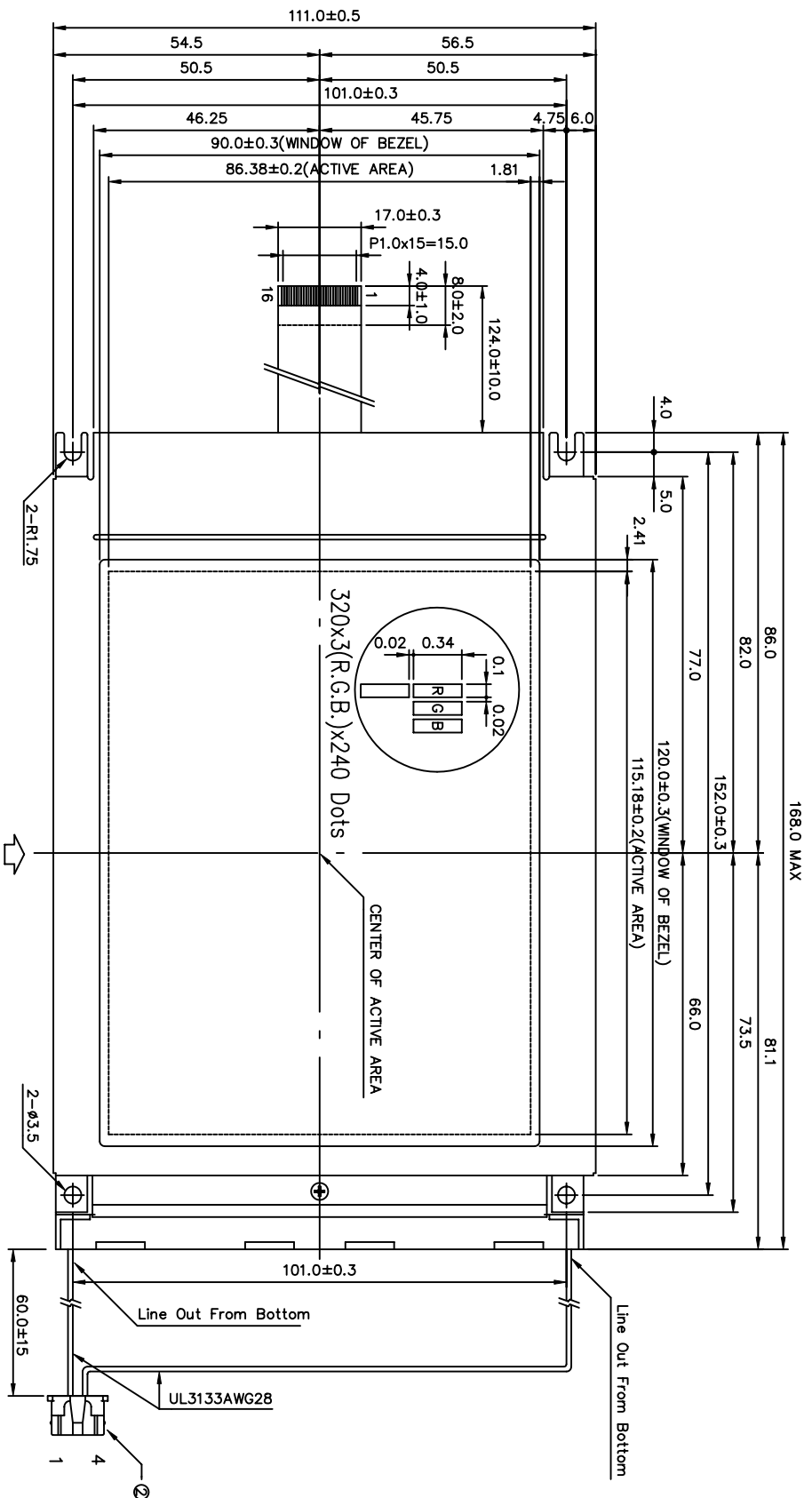

PIN ASSIGNMENT OF I/O CONNECTION

Pin No.	SYMBOL	LEVEL	FUNCTION
1	FLM	H/L	First Line Marker
2	LP	H+L	Data Latch Signal
3	CP	H+L	Data Shift Clock Signal
4	DISP-ON	H/L	H : Display On L : Display Off
5	VDD	-	Power Supply for Logic
6	VSS	-	Power Supply(GV/GND)
7	VDD	-	Power Supply for LCD Drive
8	D0	H/L	Display Data
9	D1	H/L	Display Data
10	D2	H/L	Display Data
11	D3	H/L	Display Data
12	D4	H/L	Display Data
13	D5	H/L	Display Data
14	D6	H/L	Display Data
15	D7	H/L	Display Data
16	VSS	-	Power Supply(GV/GND)

PIN ASSIGNMENT OF CCFL CONNECTION

Pin No.	SYMBOL	LEVEL	FUNCTION
1	HOT	-	Power Supply for CCFL(HOT)
2	NC	-	No Connection
3	NC	-	No Connection
4	GND	-	Power Supply for CCFL(GND)

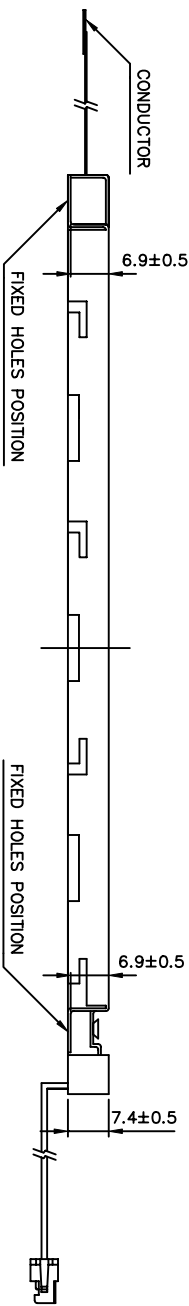

NOTE :

1. RESOLUTION : 320 X 3(R.G.B.) X 240 DOTS
2. CONTROLLER : EXCLUDED
3. DC/DC CONVERTER : EXCLUDED
4. ① INTERFACE CONNECTOR  
FFC, N16 P1.0mm
5. TOLERANCE NO SPECIFIED : ±0.5mm

② CCFT CONNECTOR

M63M83-04 (MITSUMI)



南亞塑膠工業股份有限公司  
NAN YA PLASTICS CORPORATION

製品圖

LCBHPTB61MS

REV. NO.	DESCRIPTION	DATE	DESIGN	CHECK	APPROVE

DWG NO.	NAME	DATE	THIRD ANGLE P.
M/B 61D/D10A	Campus Chen	95.02.21	1/1
	Campus Chen	95.02.21	

# THE NOTES OF LCM USING

LCM is easy to damage.

Please follow the notes as bellows, and be careful of handling!

## Correct handling

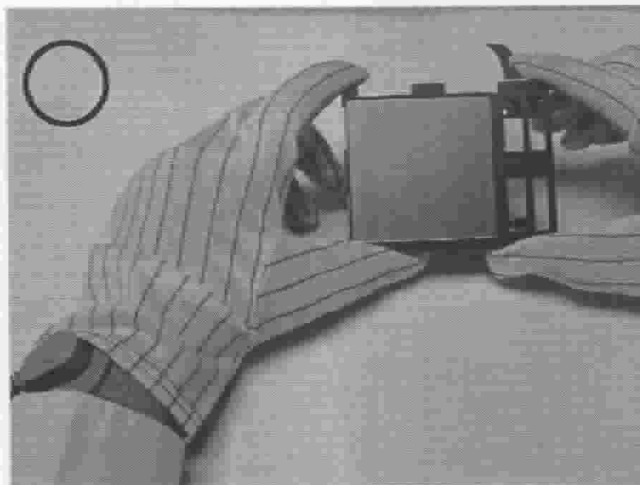
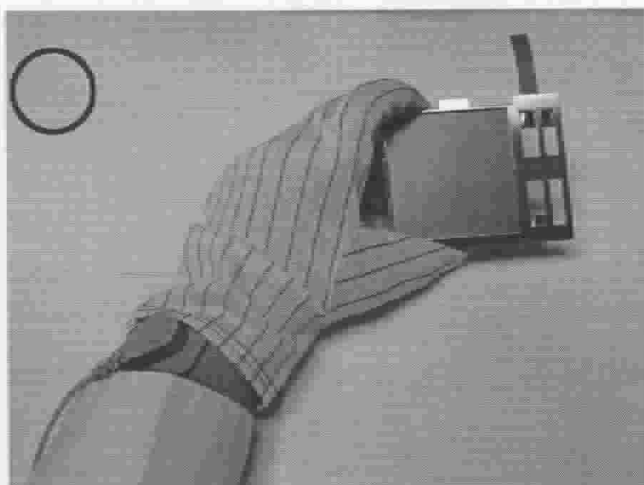

As above picture, please handle with glove by LCM edges and full EOS/ESD protection.

## Incorrect handling

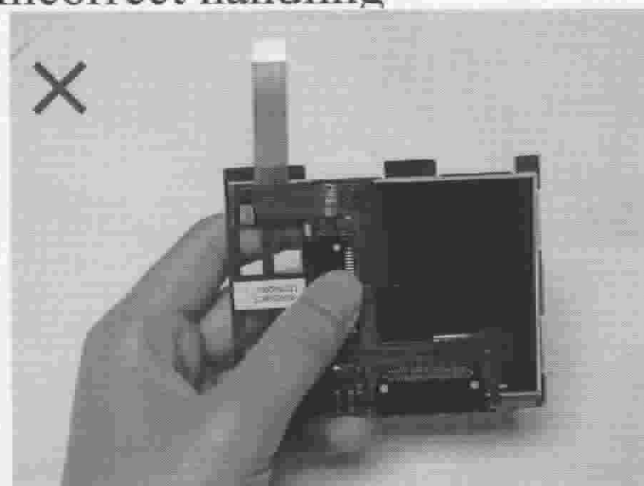

Please don't touch IC directly.

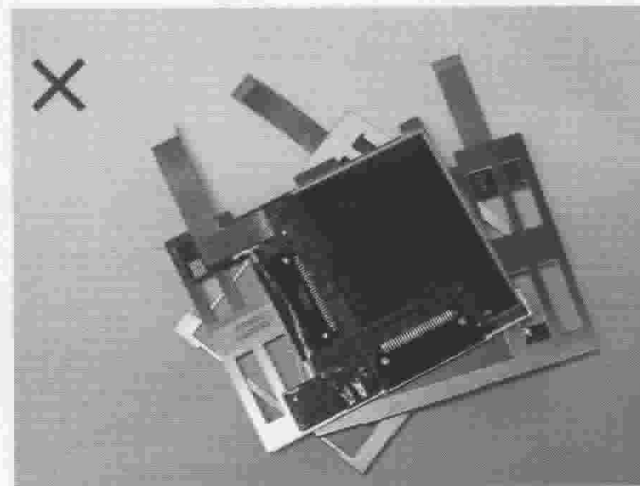

Please don't put one on another LCM.

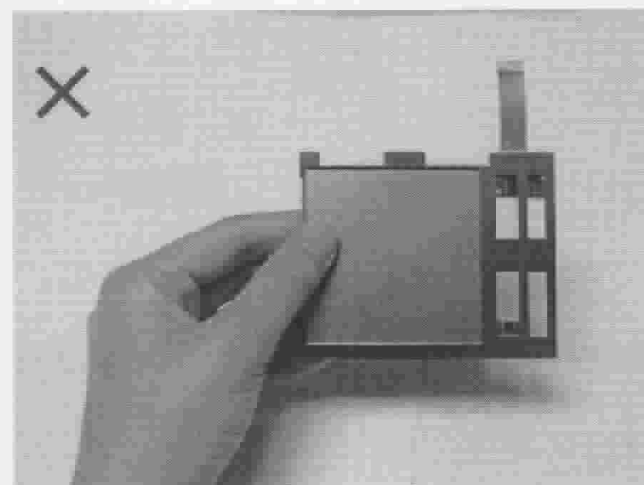

Please don't hold the surface of LCM.

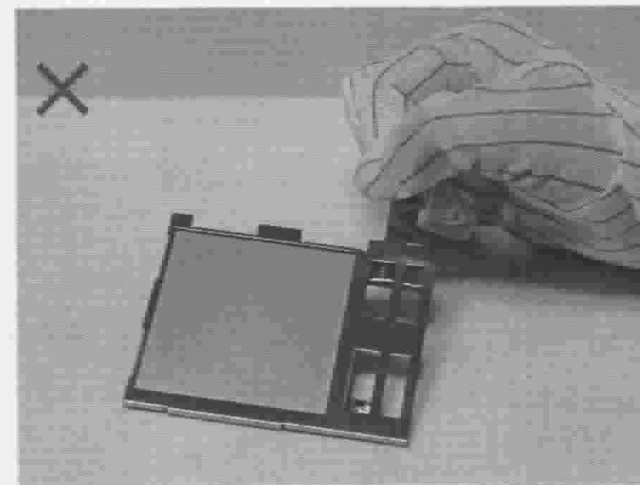

Please don't stretch interface of output.

# THE NOTES OF LCD USING

LCD is easy damage.

Please follow notes as bellows, and be careful of handling!

## Correct handling

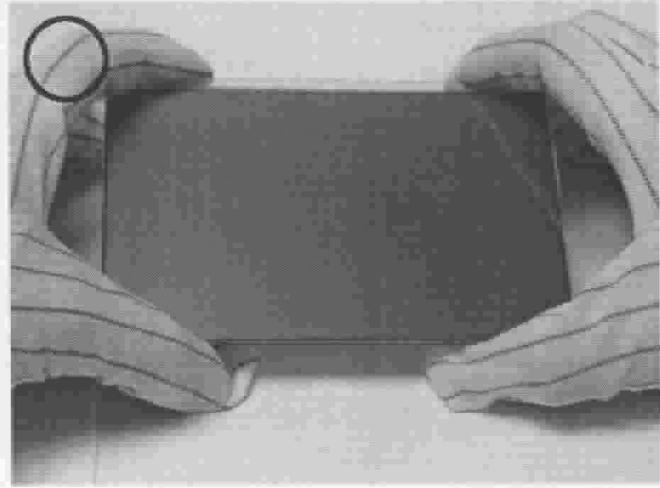
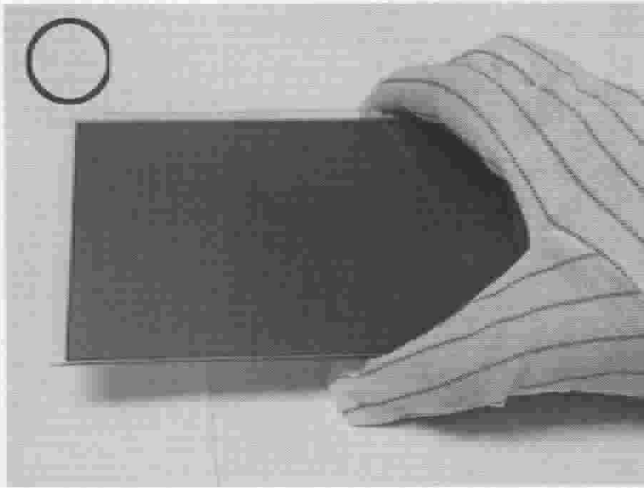

As above picture, please handle with glove by LCD edges and full EOS/ESD protection.

## Incorrect handling

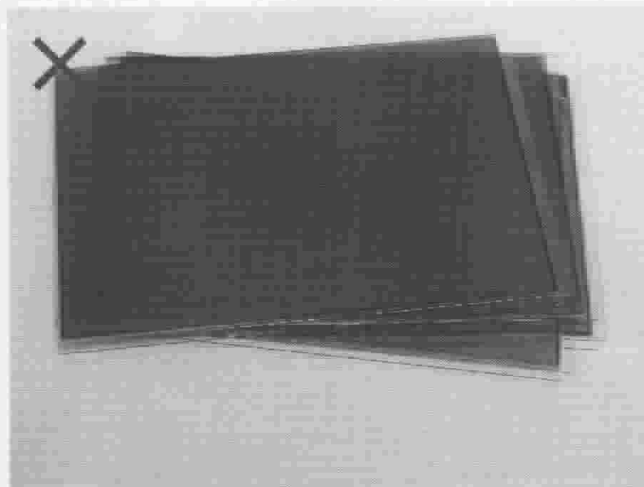

Please don't put one on another LCD.

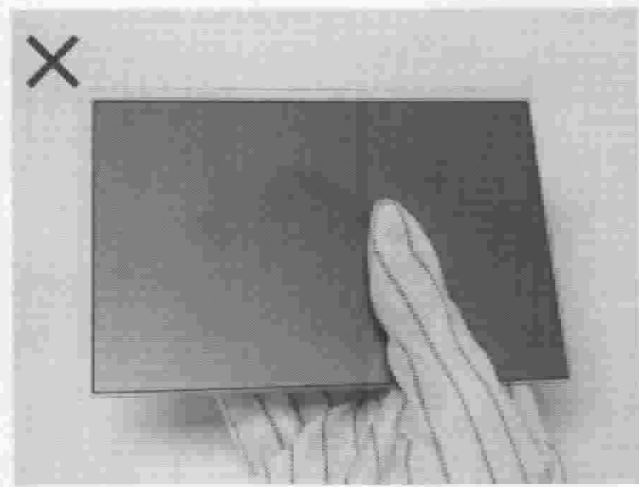

Please don't hold the surface of LCD.

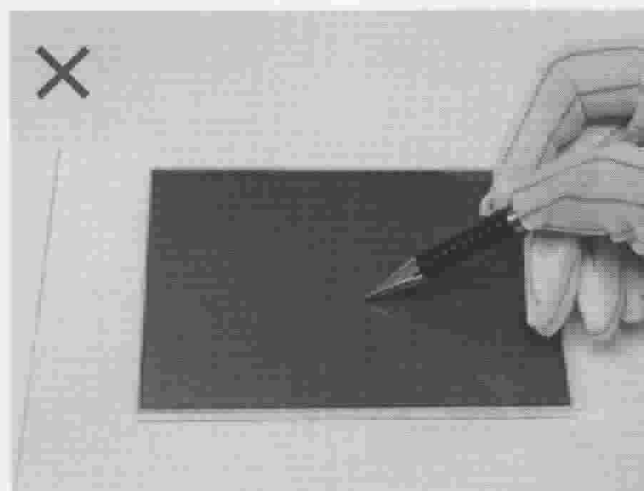

Please don't operate with sharp stick such as sharp pencil.

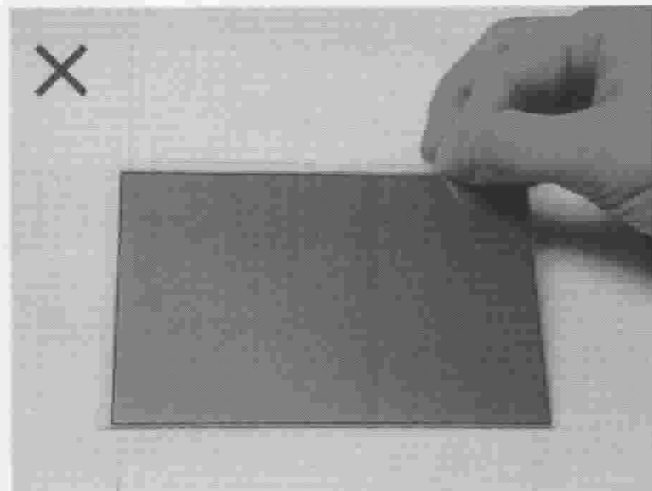

Please don't touch ITO glass without anti-static gloves.

