



NAN YA PLASTICS CORPORATION

SPECIFICATION OF
LCD MODULE
PRODUCT NO. : LCBLET163W23S_

SPEC. NO. : LM163-23-0

CUSTOMER
APPROVED BY
DATE:

EDITED ON : Nov. 02, 2007

LCD DEPARTMENT
ELECTRONIC MATERIALS DIVISION
NAN YA PLASTICS CORPORATION
201, TUNG HWA N. ROAD, TAIPEI
TEL:886-2-27122211 EXT. 5993~5995
FAX:886-2-27178253
E-mail:lcdsales@npc.com.tw

Q.C. DEPT.	DESIGN MANAGER	DESIGN CHECK	DESIGNER
			W.R.HSU

NAN YA PLASTICS CORP. ELEC. MATERIALS DIV. LCD DEPARTMENT	SPECIFICATION	SPEC. NO. : LM163-23 DATE : Nov. 02, 2007 SHEET NO. : 1
---	---------------	---

1.MECHANICAL DATA

NO.	ITEM	CONTENTS	UNIT
1	Product No.	LCBLET163W23S_	—
2	Module Size	203.0 (W) x 142.5 (H) x 6.0 (D)	mm
3	Dot Size	0.058 (W) x 0.215 (H)	mm
4	Dot Pitch	0.078 (W) x 0.235 (H)	mm
5	Number of Dots	640 RGB (W) x 480 (H)	Dot
6	Duty	1/240	—
7	LCD Display Mode	FSTN, Color STN Module	—
8	Rear Polarizer	Color Transmissive Type	—
9	Viewing Direction	9	O'clock
10	Backlight	CCFL	—
11	Controller	Excluded	—
12	DC/DC Converter	Included	—
13	Touch Panel	Excluded	—
14	Weight	185 (Approx.)	g

NOTE:

L C B L E T 1 6 3 W 23 S
 (1) (2) (3) (4) (5) (6)

NO.	ITEM	SYMBOL	DEFINITION
(1)	Backlight	B	CCFL Backlight
(2)	Reflective/Transmissive	T	Transmissive
(3)	Mode/View Angle	W	Color STN Module, 9 O'clock
(4)	Option	23	Module Version Number
(5)		S	RoHS Compliance
(6)		T	Testing Sample

Nan Ya guarantees that this project doesn't include
 any materials (6 materials) or includes less than specified
 quantities which are regulated by RoHS Compliance.

REV/DATE	R0/ 11.02.07'						BY W.R.HSU
----------	------------------	--	--	--	--	--	---------------

NAN YA PLASTICS CORP. ELEC. MATERIALS DIV. LCD DEPARTMENT	SPECIFICATION	SPEC. NO. : LM163-23 DATE : Nov. 02, 2007 SHEET NO. : 2
---	---------------	---

2.ABSOLUTE MAXIMUM RATINGS

2-1.ELECTRICAL ABSOLUTE RATINGS

VSS=0V

ITEM	SYMBOL	MIN.	MAX.	UNIT	COMMENT
Power Supply for Logic	VDD-VSS	-0.3	6.5	V	
Contrast Adjustment Voltage	VCON-VSS	0	VDD	V	
Input Voltage	VI	-0.3	VDD+0.3	V	
Static Electricity	—	—	—	—	Note 1

Note 1 LCM should be grounded during handling LCM.

2-2.ENVIRONMENTAL ABSOLUTE MAXIMUM RATINGS

ITEM	NORMAL TEMP.			
	OPERATING		STORAGE	
	MIN.	MAX.	MIN.	MAX.
Ambient Temperature(°C)	0	50	-20	70
Humidity (Without Condensation)	Note 2,4		Note 3,4	
Vibration	Note 5			

Note 2 $T_a \leq 50^\circ\text{C}$: 80%RH MAX.

Note 3 Please refer to item of reliability test.

Note 4 Background color will change slightly depending on ambient temperature.
That phenomenon is reversible.

Note 5

Frequency	5 Hz~13.95 Hz	13.95 Hz~33 Hz	33 Hz~51 Hz	51 Hz~500 Hz
Vibration Level	—	2 x 9.8 m/s ²	—	5 x 9.8 m/s ²
Vibration Width	0.2 inch	—	0.036 inch	—
Vibration Direction	X/Y/Z			
Vibration Time	20 min./cycle x 3 directions			

REV/DATE	R0/ 11.02.07'						BY W.R.HSU
----------	------------------	--	--	--	--	--	---------------

NAN YA PLASTICS CORP. ELEC. MATERIALS DIV. LCD DEPARTMENT	SPECIFICATION	SPEC. NO. : LM163-23 DATE : Nov. 02, 2007 SHEET NO. : 3-1
---	----------------------	---

3.ELECTRICAL CHARACTERISTICS

3-1.ELECTRICAL CHARACTERISTICS OF LCM

ITEM	SYMBOL	CONDITION		MIN.	TYP.	MAX.	UNIT
Power Supply for Logic	VDD-VSS	—		3.15	3.3	3.45	V
Input Voltage	VIH	H Level		0.8VDD	—	VDD	V
	VIL	L Level		0	—	0.2VDD	
Contrast Adjustment Voltage	VCON-VSS	Duty = 1/240	0°C	1.2	1.6	2.0	V
			25°C	1.4	1.8	2.2	
			50°C	1.6	2.0	2.4	
Power Supply Current (Ta=25°C)	IDD	VDD-VSS=3.3V VCON-VSS=1.8V Pattern: 		—	110.0	170.0	mA
LCM Surface Luminance (Ta=25°C)	L	VDD-VSS = 3.3V VCON-VSS=1.8V IL=5mArms	Dots All On (White)	45	70	—	cd/m ²
			Dots All Off (Black)	—	5	—	
Recommended Frame Frequency for Optimum Contrast	FLM	—		115	120	125	Hz

REV/DATE	R0/ 11.02.07'						BY W.R.HSU
----------	------------------	--	--	--	--	--	---------------

NAN YA PLASTICS CORP. ELEC. MATERIALS DIV. LCD DEPARTMENT	SPECIFICATION	SPEC. NO. : LM163-23 DATE : Nov. 02, 2007 SHEET NO. : 3-2
---	---------------	---

3-2.ELECTRICAL CHARACTERISTICS OF BACKLIGH'

Used Lamp Rating

Ta=25°C

ITEM	SYMBOL	MIN.	TYP.	MAX.	UNIT	REMARK
Lamp Voltage	VL	—	434	—	Vrms	—
Lamp Current	IL	—	5	—	mArms	—
Lamp Power Consumption	PL	—	2.17	—	W	(*1)
Starting Voltage	VS	—	—	950	Vrms	Ta=25°C
		—	—	1240	Vrms	Ta=0°C
Lamp life time	LL	20000	—	—	Hrs	at IL=5 mArms Ta=25°C(*2)

(*1) Power consumption excluded inverter loss.

(*2) Lamp life time is defined as follows : The final brightness is at 50% of original brightness.

(*3) a. Please follow the table of lamp characteristics shown above if not to use the inverter tested by Nan Ya.
 b. If customers want to design inverter by themselves, please inform Nan Ya to offer the detail lamp specification.

REV/DATE	R0/ 11.02.07'							BY	W.R.HSU
----------	------------------	--	--	--	--	--	--	----	---------

NAN YA PLASTICS CORP. ELEC. MATERIALS DIV. LCD DEPARTMENT	SPECIFICATION	SPEC. NO. : LM163-23 DATE : Nov. 02, 2007 SHEET NO. : 3-3
---	----------------------	---

3-3.ELECTRICAL CHARACTERISTICS OF TESTED INVERTER

TDK TAD250

(If the inverter output "CP2" couldn't mating CCFL connector, please refer to specification "INTERNAL PIN CONNECTION" page to fit it.)

3-3-1 GENERAL SPECIFICATIONS

OPERATION TEMPERATURE : 0°C ~50°C
 STORAGE TEMPERATURE : -20°C ~80°C
 DIMENSION : 95.0(L)mm x 19.5(W)mm x MAX. 8.8(H)mm

3-3-2 PIN ASSIGNMENTS

INPUT(CP1) CONNECTOR :
 MOLEX 53261-0590

NO.	FUNCTION
1	VIN
2	GND
3	^{V_{rmt}} ON/OFF CONTROL
4	Vctrl
5	NC

OUTPUT(CN2) CONNECTOR :
 MITSUMI M60-04-30-134P

NO.	FUNCTION
1	RTN
2	NC
3	NC
4	HV

3-3-3 RELATIONSHIP BETWEEN VIN & TUBE CURRENT

- (1) Backlight measurement brightness based on the TDK TAD250 inverter.
- (2) Test condition : Turn on the module CCFL backlight with TAD250.

ITEM	SYMBOL	MIN.	TYP.	MAX.	UNIT	REMARK
Input Voltage	VIN	10	12	15	V	
Control Terminal Input Voltage	V _{rmt}	3.5	5	10	V	ON State
		-0.5	0	0.4		OFF State
Tube Current Control Voltage	Vctrl	—	1.2	—	V	
Tube Current	IL	—	5	—	mA	

Note 1. Inverter must be used in the range of VIN Input Voltage.
 If it doesn't used in this range, the electrical characteristics of backlight would not be to guarantee.

REV/DATE	R0/ 11.02.07'								BY W.R.HSU
----------	------------------	--	--	--	--	--	--	--	---------------

NAN YA PLASTICS CORP. ELEC. MATERIALS DIV. LCD DEPARTMENT	SPECIFICATION	SPEC. NO. : LM163-23 DATE : Nov. 02, 2007 SHEET NO. : 4-1
---	---------------	---

4.OPTICAL CHARACTERISTICS

4-1.Optical Char. of Normal Temp. Mode

at Vop

ITEM		Cr(Contrast Ratio)						θ (Viewing Angle)		φ (Viewing Angle)	
		0 °C		25 °C		50 °C		25 °C		25 °C	
MODE		MIN.	TYP.	MIN.	TYP.	MIN.	TYP.	Viewing Direction	TYP.	Viewing Direction	TYP.
T	W	12.5	17	14	20	5.5	8	6 O'Clock	35	9 O'Clock	40
								12 O'Clock	35	3 O'Clock	30
NOTE		NOTE 3,6									

NOTE :

T : Transmissive

W : Color STN Module, 9 O'clock

at $\varphi = 0^\circ, \theta = 0^\circ$

ITEM	SYMBOL	CONDITION	MIN.	TYP.	MAX.	UNIT	NOTE
Response Time (rise)	Tr	0 °C	680	840	1250	ms	NOTE 2,3
		25 °C	280	350	525		
		50 °C	150	190	285		
Response Time (fall)	Tf	0 °C	360	450	675	ms	NOTE 2,3
		25 °C	110	140	210		
		50 °C	70	85	125		

REV/DATE	R0/ 11.02.07'						BY W.R.HSU
----------	------------------	--	--	--	--	--	---------------

4-2.Color of CIE Coordinate

Ta=25°C

ITEM	SYMBOL	CONDITION	VALUE			NOTE	
			MIN.	TYP.	MAX.		
Color of CIE Coordinate	Red	x	$\varphi = 0^\circ, \theta = 0^\circ$	0.45	0.5	0.55	Note※
		y		0.26	0.31	0.36	
	Green	x	$\varphi = 0^\circ, \theta = 0^\circ$	0.24	0.29	0.34	
		y		0.46	0.51	0.56	
	Blue	x	$\varphi = 0^\circ, \theta = 0^\circ$	0.12	0.17	0.22	
		y		0.1	0.15	0.2	
	White	x	$\varphi = 0^\circ, \theta = 0^\circ$	0.24	0.29	0.34	
		y		0.28	0.33	0.38	

Note※ Measuring at position 3 on Fig.1 CIE chromaticity diagram

Fig.1

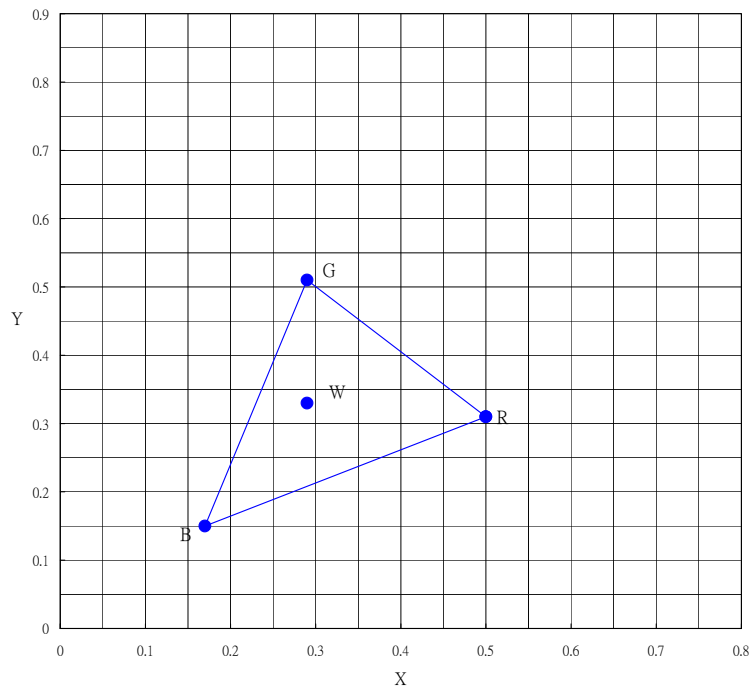

(NOTE 1)

Definition of Operation Voltage(Vop)

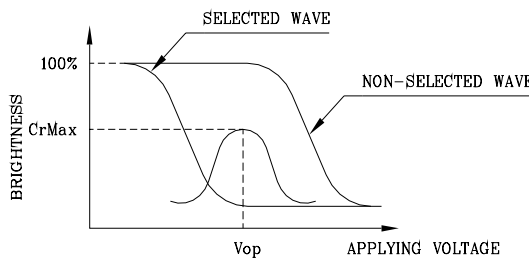

(positive type)

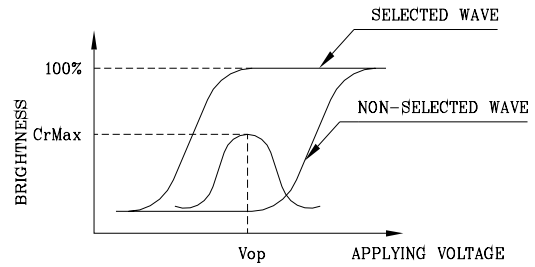

(negative type)

*Conditions

Viewing Angle : 0
 Frame Frequency : 120Hz
 Applying Waveform : 1/N duty 1/a bias

(NOTE 2)

Definition of Response Time(Tr,Tf)

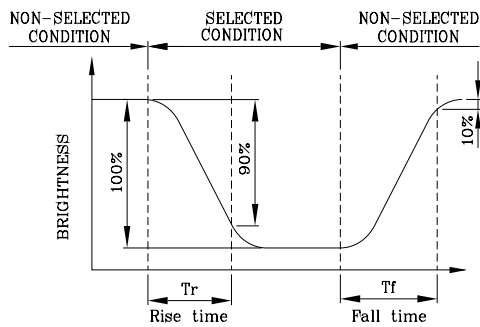

(positive type)

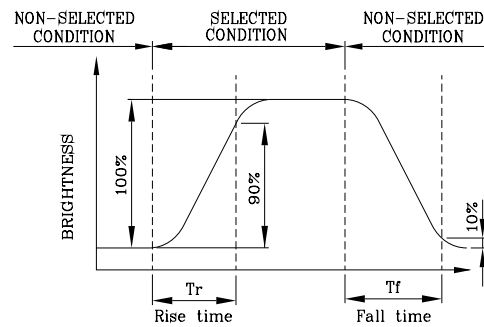

(negative type)

*Conditions

Operating Voltage : Vop
 Viewing Angle (θ,φ) : (0,0)
 Frame Frequency : 120Hz
 Applying Waveform : 1/N duty 1/a bias

(NOTE 3)

Description of Measuring Equipment and Driving Waveforms

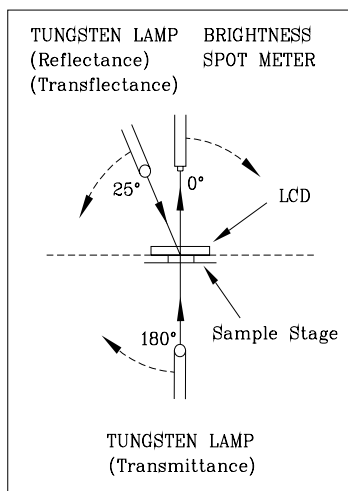

CONST.
 TEMP.
 CHAMBER

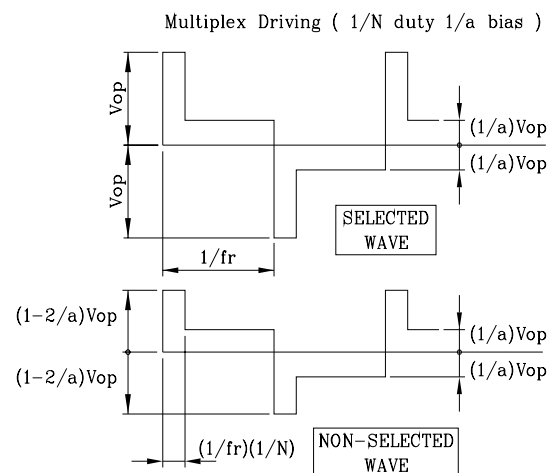

(NOTE 4)

Definition of Viewing Direction

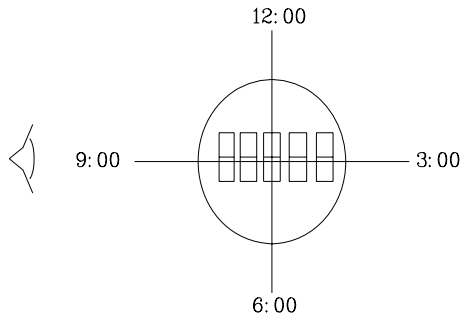

(NOTE 5)

Definition of Viewing Angle

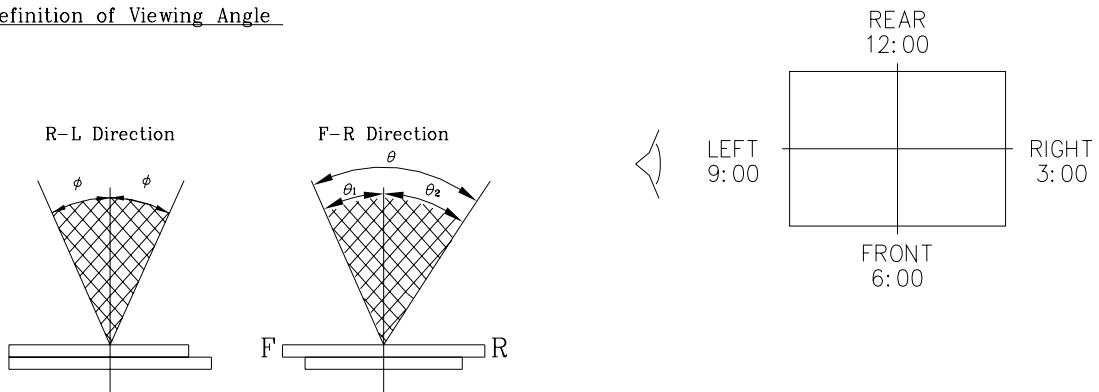

$$\theta = \theta_1 + \theta_2$$

*Conditions

Operating Voltage : V_{op}
 Frame Frequency : 120Hz
 Applying Waveform : 1/N duty 1/a bias
 Contrast Ratio : larger than 2

(NOTE 6)

Definition of Contrast Ratio (Cr)

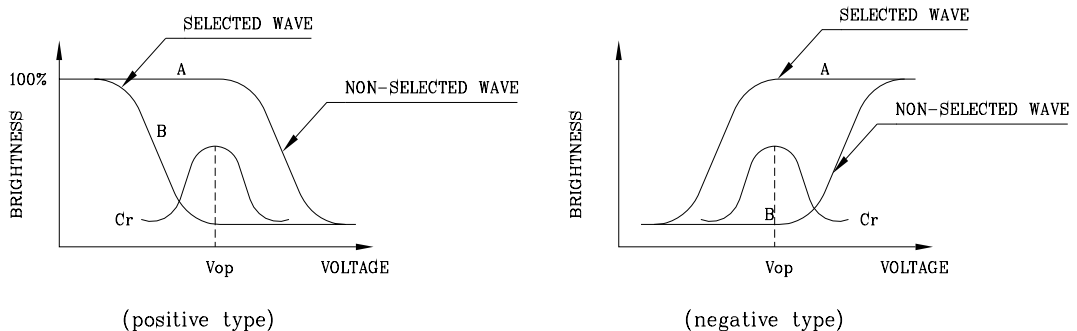

Contrast Ratio : $Cr = A/B$

*Conditions

Viewing Angle : 0
 Frame Frequency : 120Hz
 Applying Waveform : 1/N duty 1/a bias

REV/DATE	R0/ 11.02.07'						BY W.R.HSU
----------	------------------	--	--	--	--	--	---------------

5. BLOCK DIAGRAM

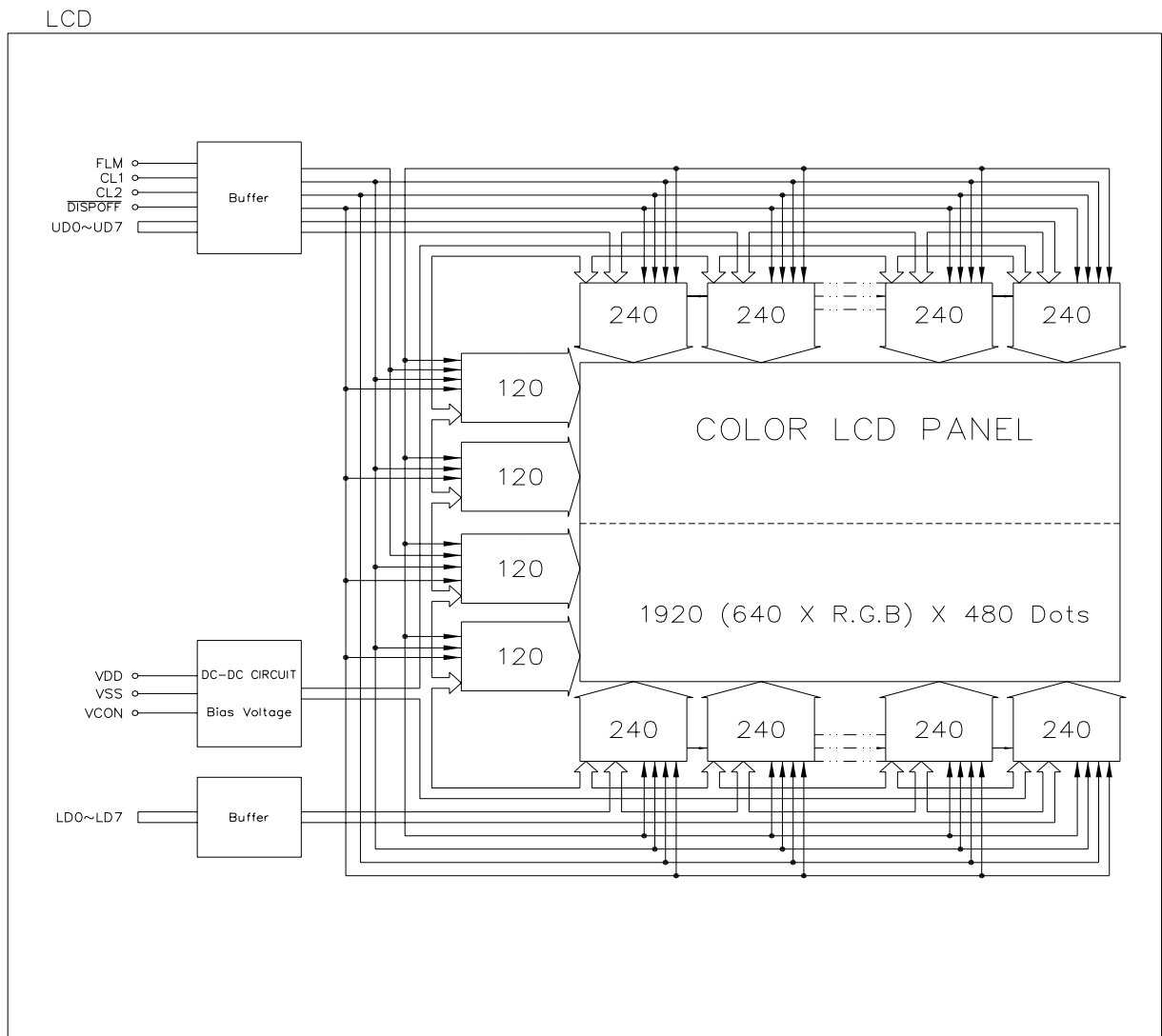

REV/DATE	R0/ 11.02.07'						BY W.R.HSU
----------	------------------	--	--	--	--	--	---------------

6.INTERNAL PIN CONNECTION

LCD

Pin No.	Symbol	Level	Function	Pin No.	Symbol	Level	Function
1	LD0	H/L	Display Data (Lower Column)	19	VCON	—	Contrast Adjust
2	LD1	H/L	Display Data (Lower Column)	20	VSS	—	GND
3	LD2	H/L	Display Data (Lower Column)	21	VSS	—	GND
4	LD3	H/L	Display Data (Lower Column)	22	UD0	H/L	Display Data (Upper Column)
5	VSS	—	GND	23	UD1	H/L	Display Data (Upper Column)
6	LD4	H/L	Display Data (Lower Column)	24	UD2	H/L	Display Data (Upper Column)
7	LD5	H/L	Display Data (Lower Column)	25	UD3	H/L	Display Data (Upper Column)
8	LD6	H/L	Display Data (Lower Column)	26	VSS	—	GND
9	LD7	H/L	Display Data (Lower Column)	27	UD4	H/L	Display Data (Upper Column)
10	VSS	—	GND	28	UD5	H/L	Display Data (Upper Column)
11	FLM	H	First Line Marker	29	UD6	H/L	Display Data (Upper Column)
12	/DISPOFF	H/L	H : ON / L : OFF	30	UD7	H/L	Display Data (Upper Column)
13	CL1	Level	Data Latch	31	VSS	—	GND
14	VSS	—	GND	32	NC	—	No Connection
15	CL2	Level	Data Shift	33	NC	—	No Connection
16	VSS	—	GND	34	NC	—	No Connection
17	VDD	—	Power Supply for Logic	35	NC	—	No Connection
18	VDD	—	Power Supply for Logic				

USED LCD CONNECTOR :

MOLEX 54104-3596 or COMPATIBLE

CORRESPONDABLE LCD CONNECTOR :

FFC/FPC,N35,Pitch 0.5 mm (Thickness = 0.3 mm)

CCFL

Pin No.	Symbol	Level	Function
1	VSS	—	GND for CCFL
2	NC	—	No Connection
3	NC	—	No Connection
4	VCFL	AC	Power Supply for CCFL (GND)

USED CCFL CONNECTOR :

JAE IL-G-4S-S3C2-SA or COMPATIBLE

CORRESPONDABLE CCFL CONNECTOR :

JAE IL-G-4P-S3T2-SA or COMPATIBLE

REV/DATE	R0/ 11.02.07'						BY W.R.HSU
----------	------------------	--	--	--	--	--	---------------

8.TIMING CHARACTERISTICS

8-1.INTERFACE TIMING

VDD=3.3V ± 5%

Parameter	SYMBOL	MIN.	MAX.	UNIT
CLOCK PULSE CYCLE TIME	t_{wck}	66	-	ns
CLOCK PULSE HIGH LEVEL WIDTH	t_{wckH}	23	-	ns
CLOCK PULSE LOW LEVEL WIDTH	t_{wckL}	23	-	ns
LATCH PULSE HIGH LEVEL WIDTH	t_{wLPH}	30	-	ns
CL2→CL1 RISE TIME	t_{LD}	10	-	ns
CL2→CL1 FALL TIME	t_{SL}	30	-	ns
CL1→CL2 RISE TIME	t_{LS}	30	-	ns
CL1→CL2 FALL TIME	t_{LH}	30	-	ns
CLOCK PULSE RISE/FALL TIME	t_r, t_f	-	50	ns
DATA SETUP TIME	t_{DS}	10	-	ns
DATA HOLD TIME	t_{DH}	25	-	ns
FLM SETUP TIME	t_{SU}	100	-	ns
FLM HOLD TIME	t_H	30	-	ns

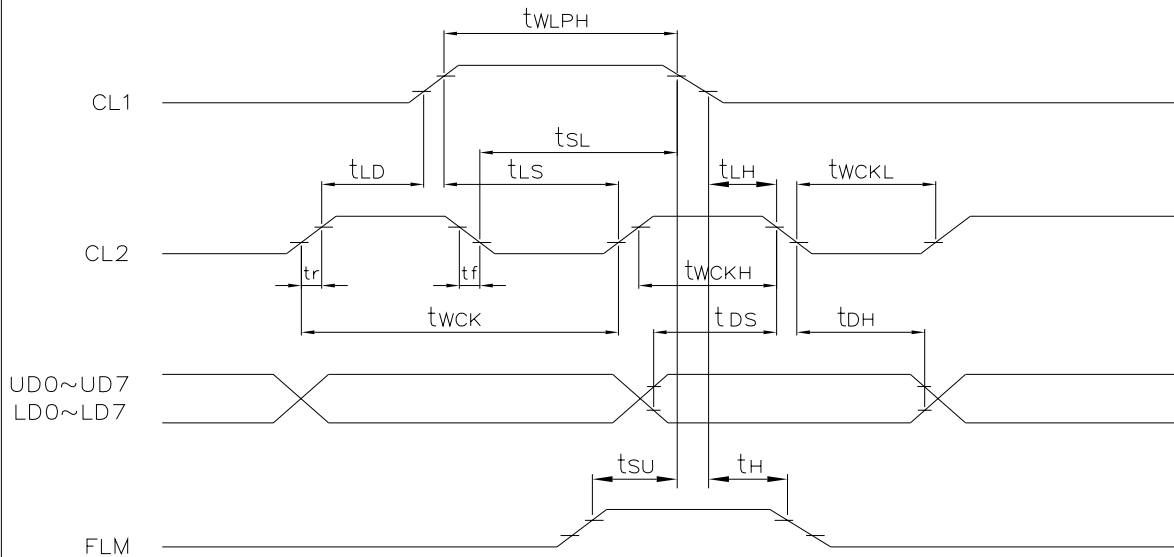

8-3.POWER ON/OFF TIMING

ON SEQUENCE

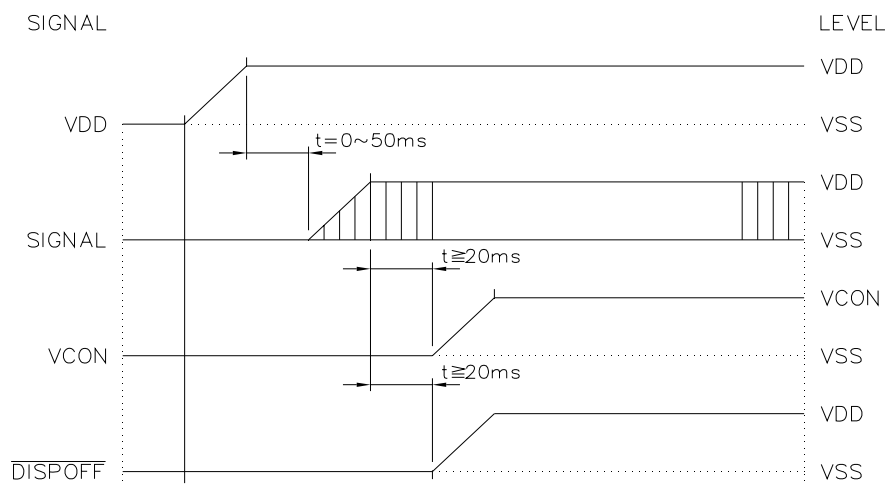

OFF SEQUENCE

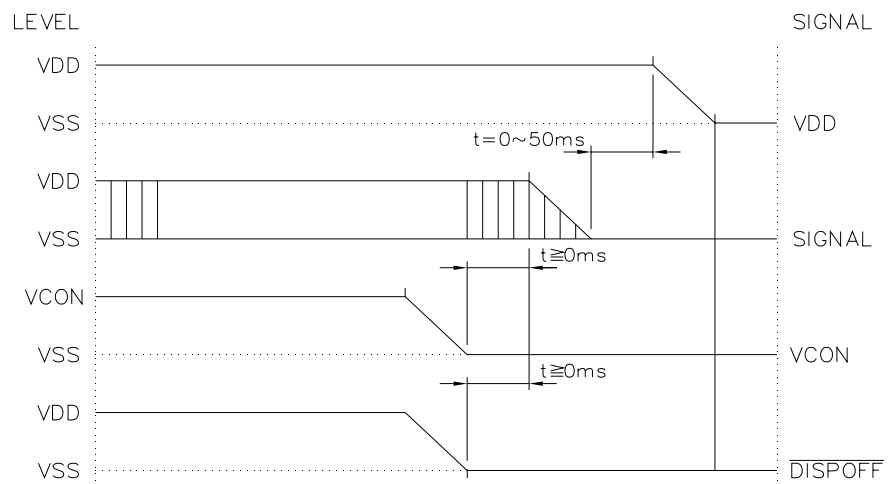

Please maintain the above sequence when turning on and off the power supply of the module. If $\overline{\text{DISPOFF}}$ is supplied to the module while internal alternate signal for LCD driving(M) is unstable, DC component will be supplied to the LCD panel. This may cause damage the LCD module.

NAN YA PLASTICS CORP. ELEC. MATERIALS DIV. LCD DEPARTMENT	SPECIFICATION	SPEC. NO. : LM163-23 DATE : Nov. 02, 2007 SHEET NO. : 9-1
---	---------------	---

9.RELIABILITY TEST

NORMAL TEMPERATURE RELIABILITY TEST

NO.	ITEM	CONDITION			STANDARD	NOTE
1	High Temp. Storage	70 °C	120 Hrs		Appearance without defect	
2	Low Temp. Storage	-20 °C	120 Hrs		Appearance without defect	
3	High Temp. & High Humi. Storage	50 °C 90%RH	120 Hrs		Appearance without defect	
4	High Temp. Operating Display	50 °C	120 Hrs		Appearance without defect	
5	Low Temp. Operating Display	0 °C	120 Hrs		Appearance without defect	
6	Thermal Shock	-20 °C, 30min. → 70°C, 30min. ↑ (1cycle) ↓			Appearance without defect	10 cycles

REV/DATE	R0/ 11.02.07'							BY	W.R.HSU
----------	------------------	--	--	--	--	--	--	----	---------

NAN YA PLASTICS CORP. ELEC. MATERIALS DIV. LCD DEPARTMENT	SPECIFICATION	SPEC. NO. : LM163-23 DATE : Nov. 02, 2007 SHEET NO. : 9-2
---	----------------------	---

Inspection Provision

1.Purpose

The NAN YA inspection provision provides outgoing inspection provision and its expected quality level based on our outgoing inspection of NAN YA LCD produces.

2.Applicable Scope

The NAN YA inspection provision is applicable to the arrangement in regard to outgoing inspection and quality assurance after outgoing.

3.Technical Terms

3-1 NAN YA Technical Terms



4.Outgoing Inspection

4-1 Inspection Method

MIL-STD-105E Level II Regular inspection

4-2 Inspection Standard

	Item		AQL(%)	Remarks
Major Defect	Dots	Opens	0.4	faults which substantially lower the practicality and the initial purpose difficult to achieve.
		Shorts		
	Erroneous operation			
Solder appearance	Shorts	0.4	faults which substantially lower the practicality and the initial purpose difficult to achieve.	
	Loose			
Cracks	Display surface cracks	0.4	faults which substantially lower the practicality and the initial purpose difficult to achieve.	

REV/DATE	R0/ 11.02.07'						BY W.R.HSU
----------	------------------	--	--	--	--	--	---------------

NAN YA PLASTICS CORP. ELEC. MATERIALS DIV. LCD DEPARTMENT	SPECIFICATION	SPEC. NO. : LM163-23 DATE : Nov. 02, 2007 SHEET NO. : 9-3
---	----------------------	---

	Dimensions	External from Dimensions	0.4	
Minor Defect	Inside the glass	Black spots	0.65	faults which appear to pose almost no obstacle to the practicality, effective use, and operation.
	Polarizing plate	Scratches, foreign Matter, air bubbles, and peeling		
	Dots	Pinhole, deformation		
	Color tone	Color unevenness		
	Solder appearance	Cold solder Solder projections		

4-3 Inspection Provisions

*Viewing Area Definition

Fig. 1

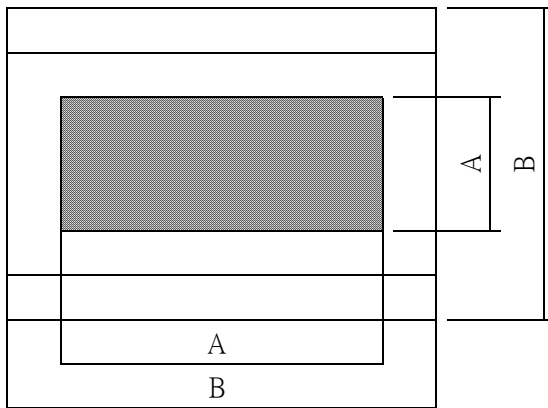

A : Zone Viewing Area
 B : Zone Glass Plate Outline

*Inspection place to be 500 to 1000 lux illuminance uniformly without glaring.
 The distance between luminous source(daylight fluorescent lamp and cool white fluorescent lamp) and sample to be 30 cm to 50 cm.

REV/DATE	R0/ 11.02.07'							BY	W.R.HSU
----------	------------------	--	--	--	--	--	--	----	---------

NAN YA PLASTICS CORP. ELEC. MATERIALS DIV. LCD DEPARTMENT	SPECIFICATION	SPEC. NO. : LM163-23 DATE : Nov. 02, 2007 SHEET NO. : 9-4
---	---------------	---

*Test and measurement are performed under the following conditions, unless otherwise specified.

Temperature $20 \pm 15^{\circ}\text{C}$
 Humidity $65 \pm 20\%\text{R.H.}$
 Pressure 860~1060hPa(mmbar)

In case of doubtful judgment, it is performed under the following conditions.

Temperature $20 \pm 2^{\circ}\text{C}$
 Humidity $65 \pm 5\%\text{R.H.}$
 Pressure 860~1060hPa(mmbar)

5.Specification for quality check

5-1 Electrical characteristics

NO.	Item	Criterion
1	Non operational	Fail
2	Miss operating	Fail
3	Missing dot	Fail
4	Contrast irregular	Fail
5	Response time	Within Specified value
6	Backlight turn on/off	Within Specified value

REV/DATE	R0/ 11.02.07'							BY	W.R.HSU
----------	------------------	--	--	--	--	--	--	----	---------

SPECIFICATION

5-2 External Appearance Defect

NO.	Item	Criterion																							
1	Black spots, foreign matter, and white spots (Including light leakage due to pinholes of polarizing plates, etc.)	<p>(1)-1-Spots</p> <table border="1" data-bbox="810 600 1358 913"> <thead> <tr> <th>Average Diameter (mm):D</th> <th>Number of pieces permitted</th> <th>Minimum Space</th> </tr> </thead> <tbody> <tr> <td>$D \leq 0.2$</td> <td>Ignore</td> <td>—</td> </tr> <tr> <td>$0.2 < D \leq 0.3$</td> <td>5</td> <td>10mm</td> </tr> <tr> <td>$0.3 < D \leq 0.4$</td> <td>2</td> <td>30mm</td> </tr> <tr> <td>$0.4 < D$</td> <td>0</td> <td>—</td> </tr> </tbody> </table> <p>Number of total pieces is set to within 5 pieces.</p> <p>Note that when there are 2 pieces or more, they are not to be concentrated. Set as: Average diameter = (Long diameter + Short diameter)/2</p> <p>(1)-2-Blurred Spots(At lighting condition)</p> <table border="1" data-bbox="810 1263 1358 1487"> <thead> <tr> <th>Average Diameter (mm):D</th> <th>Number of pieces permitted</th> </tr> </thead> <tbody> <tr> <td>$D \leq 0.3$</td> <td>Ignore</td> </tr> <tr> <td>$0.3 < D \leq 0.75$</td> <td>5</td> </tr> <tr> <td>$0.75 < D$</td> <td>0</td> </tr> </tbody> </table> <p>Number of total pieces is set to within 5 pieces.</p> <p>Note that when there are 2 pieces or more, they are not to be concentrated. Set as: Average diameter = (Long diameter + Short diameter)/2</p>	Average Diameter (mm):D	Number of pieces permitted	Minimum Space	$D \leq 0.2$	Ignore	—	$0.2 < D \leq 0.3$	5	10mm	$0.3 < D \leq 0.4$	2	30mm	$0.4 < D$	0	—	Average Diameter (mm):D	Number of pieces permitted	$D \leq 0.3$	Ignore	$0.3 < D \leq 0.75$	5	$0.75 < D$	0
Average Diameter (mm):D	Number of pieces permitted	Minimum Space																							
$D \leq 0.2$	Ignore	—																							
$0.2 < D \leq 0.3$	5	10mm																							
$0.3 < D \leq 0.4$	2	30mm																							
$0.4 < D$	0	—																							
Average Diameter (mm):D	Number of pieces permitted																								
$D \leq 0.3$	Ignore																								
$0.3 < D \leq 0.75$	5																								
$0.75 < D$	0																								

SPECIFICATION

1	Line	<p>(1)-1-Lines</p> <table border="1" data-bbox="810 465 1353 734"> <thead> <tr> <th>Width(mm):W</th> <th>Length(mm): L</th> <th>Number of pieces permitted</th> </tr> </thead> <tbody> <tr> <td>$W \leq 0.03$</td> <td>Ignore</td> <td>Ignore</td> </tr> <tr> <td>$0.03 < W \leq 0.08$</td> <td>$L \leq 4$</td> <td>2</td> </tr> <tr> <td>$0.08 < W \leq 0.1$</td> <td>$L \leq 1$</td> <td>1</td> </tr> </tbody> </table> <p>Object exceeding 0.1mm follow the standards of the spots form. Note that when there are 2 pieces or more, they are not to be concentrated.</p> <p>(1)-2-Blurred Lines(At lighting condition)</p> <table border="1" data-bbox="810 1003 1353 1272"> <thead> <tr> <th>Width(mm):W</th> <th>Length(mm): L</th> <th>Number of pieces permitted</th> </tr> </thead> <tbody> <tr> <td>$W \leq 0.03$</td> <td>Ignore</td> <td>Ignore</td> </tr> <tr> <td>$0.03 < W \leq 0.08$</td> <td>$L \leq 3$</td> <td>6</td> </tr> <tr> <td>$0.08 < W$</td> <td>$3 < L$</td> <td>None</td> </tr> </tbody> </table> <p>Object exceeding 0.1mm follow the standards of the spots form. Note that when there are 2 pieces or more, they are not to be concentrated.</p>	Width(mm):W	Length(mm): L	Number of pieces permitted	$W \leq 0.03$	Ignore	Ignore	$0.03 < W \leq 0.08$	$L \leq 4$	2	$0.08 < W \leq 0.1$	$L \leq 1$	1	Width(mm):W	Length(mm): L	Number of pieces permitted	$W \leq 0.03$	Ignore	Ignore	$0.03 < W \leq 0.08$	$L \leq 3$	6	$0.08 < W$	$3 < L$	None
Width(mm):W	Length(mm): L	Number of pieces permitted																								
$W \leq 0.03$	Ignore	Ignore																								
$0.03 < W \leq 0.08$	$L \leq 4$	2																								
$0.08 < W \leq 0.1$	$L \leq 1$	1																								
Width(mm):W	Length(mm): L	Number of pieces permitted																								
$W \leq 0.03$	Ignore	Ignore																								
$0.03 < W \leq 0.08$	$L \leq 3$	6																								
$0.08 < W$	$3 < L$	None																								
2	Scratches(Glass, reflection plates, and polarizing plates)	In accordance with black spots. (At non lighting condition)																								
3	Color irregular	Not remarkable color irregular.																								

SPECIFICATION

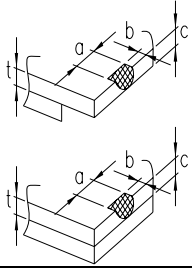
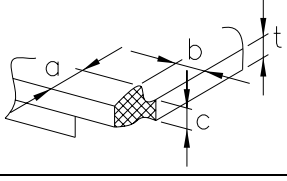
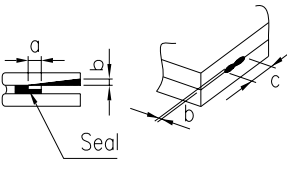
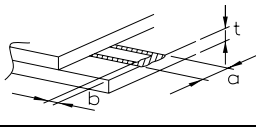
4	Air bubbles polarizing plates, and reflection plates	<table border="1" data-bbox="810 421 1193 645"> <thead> <tr> <th>Average Diameter (mm):D</th> <th>Number of pieces permitted</th> </tr> </thead> <tbody> <tr> <td>$D \leq 0.3$</td> <td>Ignore</td> </tr> <tr> <td>$0.3 < D$</td> <td>0</td> </tr> </tbody> </table> <p data-bbox="1193 443 1369 629">Average diameter = (Long diameter + Short diameter)/2</p> <p data-bbox="815 658 1369 725">Note that when there are 4 pieces or more, they are not to be concentrated.</p>		Average Diameter (mm):D	Number of pieces permitted	$D \leq 0.3$	Ignore	$0.3 < D$	0
Average Diameter (mm):D	Number of pieces permitted								
$D \leq 0.3$	Ignore								
$0.3 < D$	0								
5	Cracks	<p>(1)General crack</p> 	<p>$a \leq 5$ $b \leq 2$ $c \leq t$</p> <p>Where, a and b are ignored when less than or equal to 0.5 . The numbers of pieces are set at up to 5 pieces.</p>						
		<p>(2)Corner crack</p> 	<p>$a \leq 2.5$ $b \leq 2.5$ $c \leq t$ $a+b \leq 4$</p>						
		<p>(3)Seal portion crack</p> 	<p>$a \leq \text{The seal width} \times 1/3$ $b \leq t \times 2/3$ $c \leq 5$</p> <p>The numbers of pieces are set at up to 5 pieces.</p>						
		<p>(4)ITO Pin crack</p> 	<p>$a \leq 5$ $b \leq 1/3 \text{ pin length}$ $c \leq t$</p>						
		<p>(5)Progressive cracks</p>	<p>All taken to be unacceptable.</p>						

NAN YA PLASTICS CORP. ELEC. MATERIALS DIV. LCD DEPARTMENT	SPECIFICATION	SPEC. NO. : LM163-23 DATE : Nov. 02, 2007 SHEET NO. : 9-8
---	----------------------	---

6	Outer dimensions	Should be within the tolerance.
7	Newton ring(touch panel)	Orbicular of interference fringes is not allowed in the optimum contrast within the active area under viewing angle.
8	Soldering	Should be no defective soldering such as shorting, loose terminal cold solder, peeling of printed circuit board pattern, improper mounting position, etc.

5-3 Dot Appearance Defect

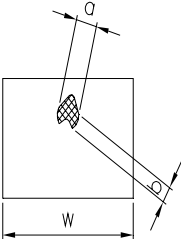
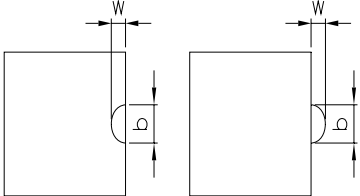
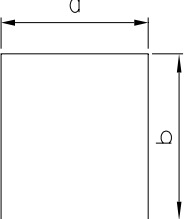
NO.	Item	Criteria	
1	Pinhole		Dot display a and b are each $\leq 0.2\text{mm}$. The overall total is taken be with in 10 units. Note that they are not to be concentrated.
2	Missing		Dot display a and b are each $\leq 0.2\text{mm}$. The overall total is taken to be with in 10 units.
3	Thick and thin display		Taken to be within $\pm 1.5\%$ of display character width(a) and height(b).

REV/DATE	R0/ 11.02.07'							BY	W.R.HSU
----------	------------------	--	--	--	--	--	--	----	---------

NAN YA PLASTICS CORP. ELEC. MATERIALS DIV. LCD DEPARTMENT	SPECIFICATION	SPEC. NO. : LM163-23 DATE : Nov. 02, 2007 SHEET NO. : 9-9
---	----------------------	---

NOTICE:

- SAFETY

1. If the LCD panel breaks, be careful not to get the liquid crystal to touch your skin.
2. If the liquid crystal touches your skin or clothes, please wash it off immediately by using soap and water.

- HANDLING

1. Avoid static electricity which can damage the CMOS LSI.
2. Do not remove the panel or frame from the module.
3. The polarizing plate of the display is very fragile. So, please handle it very carefully.
4. Do not wipe the polarizing plate with a dry cloth, as it may easily scratch the surface of plate.
5. Do not use ketonics solvent & Aromatic solvent. Use a soft cloth soaked with a cleaning naphtha solvent.

- STORAGE

1. Store the panel or module in a dark place where the temperature is $25\pm 5^{\circ}\text{C}$ and the humidity is below 65% RH.
2. Do not place the module near organics solvents or corrosive gases.
3. Do not crush, shake, or jolt the module.

- TERMS OF WARRANT

1. Acceptance inspection period
The period is within one month after the arrival of contracted commodity at the buyer's factory site.
2. Applicable warrant period
The period is within twelve months since the date of shipping out under normal using and storage conditions.

REV/DATE	R0/ 11.02.07'								BY W.R.HSU
----------	------------------	--	--	--	--	--	--	--	---------------

10. OUTLINE DRAWING

INTERNAL PIN CONNECTION
CN1 : 54104-3596 (MILLEX) or compatible

PN NO	SYMBOL	FUNCTION
1	LDD	Display Data (Lower Column)
2	LDI	Display Data (Lower Column)
3	LID	Display Data (Lower Column)
4	LDB	Display Data (Lower Column)
5	VSS	GN
6	LDA	Display Data (Lower Column)
7	LDE	Display Data (Lower Column)
8	LDE	Display Data (Lower Column)
9	LDT	Display Data (Lower Column)
10	VSS	GN
11	FLM	First Line Marker
12	DISP OFF	H : ON / L : OFF
13	CL1	Data Latch
14	VSS	GN
15	CL2	Data Shift
16	VSS	GN
17	VDD	Power Supply for Logic
18	VDD	Power Supply for Logic
19	VCN	Contrast Adjust
20	VSS	GN
21	VSS	GN
22	UD0	Display Data (Upper Column)
23	UDI	Display Data (Upper Column)
24	UD2	Display Data (Upper Column)
25	UD3	Display Data (Upper Column)
26	VSS	GN
27	UD4	Display Data (Upper Column)
28	UD5	Display Data (Upper Column)
29	UD6	Display Data (Upper Column)
30	UD7	Display Data (Upper Column)
31	VSS	GN
32	NC	No Connection
33	NC	No Connection
34	NC	No Connection
35	NC	No Connection

CN2 : IL-G-4S-SX2-SA (JAE) or compatible

PN NO	SYMBOL	FUNCTION
1	VSS	GN for CCH
2	NC	No Connection
3	NC	No Connection
4	VCH	Power supply for CCH (HV)

NOTE:

- Resolution : (640x3)x480 Dots
- Backlight : CCFL
- Frame Material : SFCC (0.5 mm, semi-gloss black paint)
- All dimensional tolerance ±0.5 unless otherwise specified

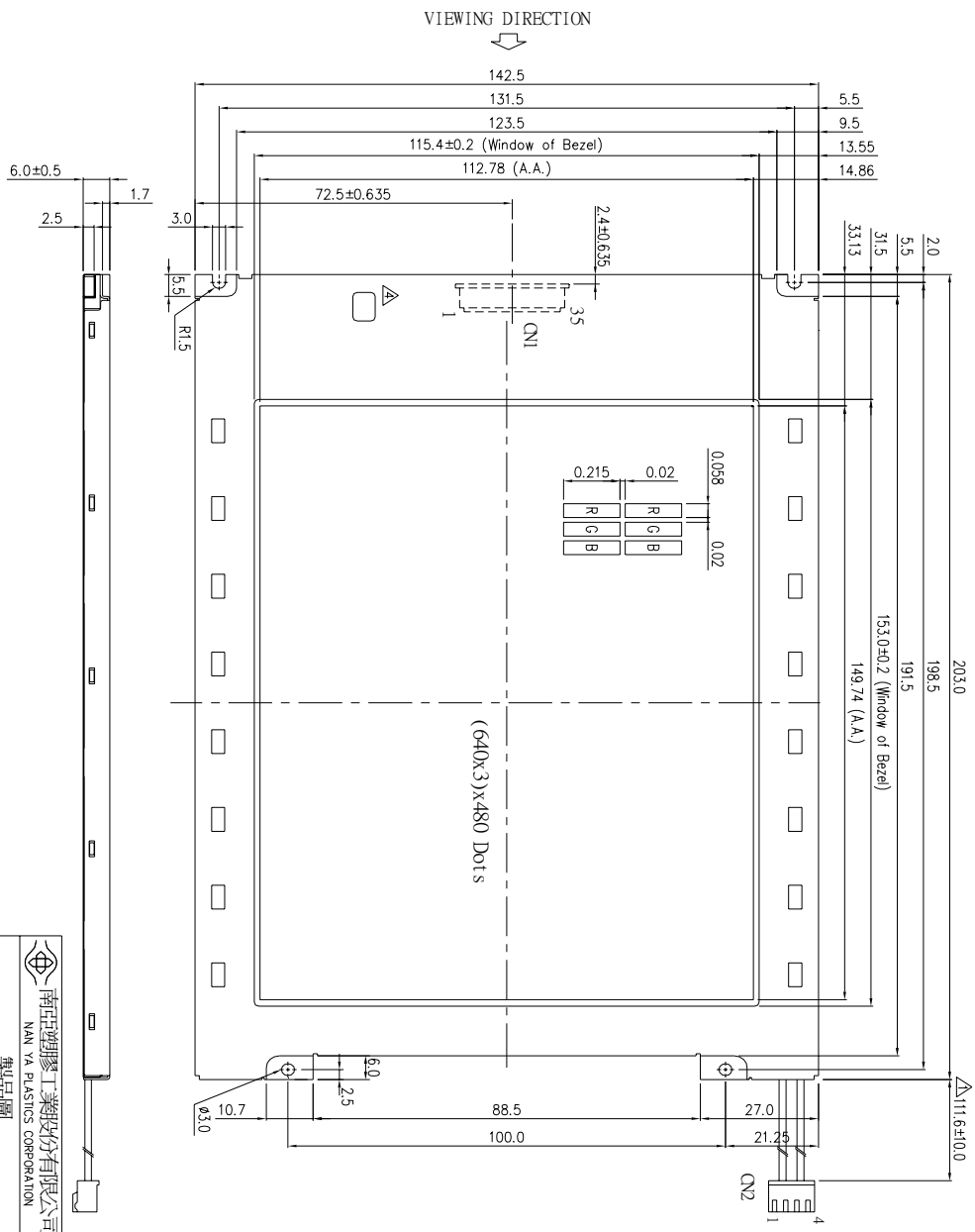

REV. NO.	DESCRIPTION	DATE	DESIGN	CHECK	APPROVE
1	Add the Bezel VR hole	96.10.12	Same Day		
2	Modified by the customer	96.09.20	Same Day	Y. C. Liu	TWY 0001
3	Modified by the customer	96.09.11	Same Day	Y. C. Liu	TWY 0001
4	Modified by the customer	96.09.05	Same Day	Y. C. Liu	TWY 0001

南亞塑膠工業股份有限公司
NAN YA PLASTICS CORPORATION
LCD PART 63W23S
製造品圖

APPROVE	NAME	DATE	THIRD ANGLE P
CHECK	Compos Chen	96.08.30	SCALE UNIT
DESIGN	Compos Chen	96.08.30	1/1
DRAWN			mm