

NAN YA PLASTICS CORPORATION

SPECIFICATION OF
LCD MODULE
PRODUCT NO.: LDA94Z677VAKS

SPEC. NO.: LM677-0A-△

CUSTOMER
APPROVED BY
DATE:

LCD DEPARTMENT
ELECTRONIC MATERIALS DIVISION
NAN YA PLASTICS CORPORATION
201, TUNG HWA N. ROAD, TAIPEI
TEL: 886-2-27122211 EXT. 5993~5995
FAX: 886-2-27178253
E-mail: lcdsales@npc.com.tw

EDITED ON : March.15.2006

Q.C. DEPT.	DESIGN MANAGER	DESIGN CHECK	DESIGNER
			C.Y.CHAN

1. MECHANICAL DATA

NO	ITEM	CONTENTS	UNIT
1	Product No.	LDA94Z677VAKS	-
2	Module Size	90.6 (W) x 77.7 (H) x MAX2.1 (D)	mm
3	Dot Size	0.418 (W) x 0.468 (H)	mm
4	Dot Pitch	0.43 (W) x 0.48 (H)	mm
5	Number of Dots	192 (W) x 64 (H)	Dot
6	Duty	1/64	-
7	LCD Display Mode	Black and White(Normal White/Positive Image)	-
8	Rear Polarizer	Reflective Type	-
9	Viewing Direction	6	O'clock
10	Backlight	Excluded	-
11	Controller	S1D15710D00B000(EPSON)	-
12	DC/DC Converter	Excluded	-
13	Touch Panel	Excluded	-
14	Weight	20 (Approx.)	g

Note :

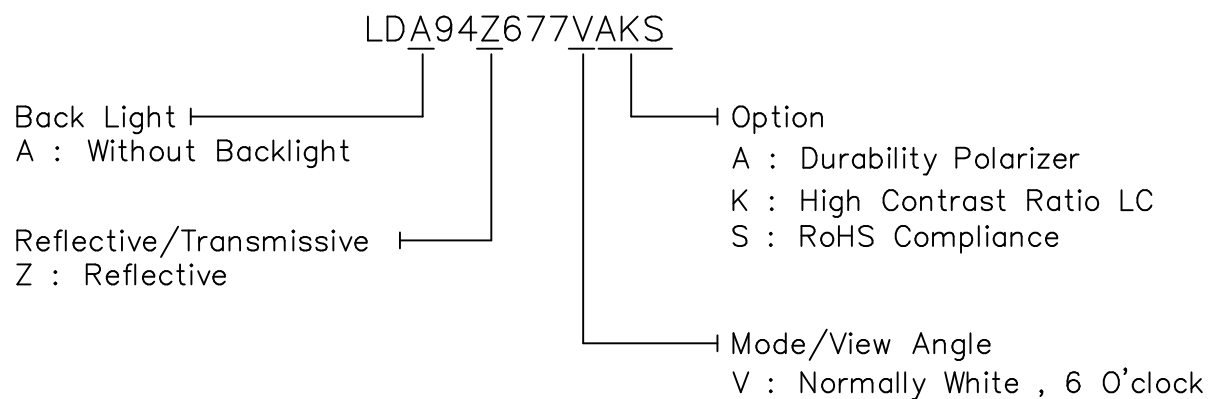

RoHS Compliance.

Nan Ya guarantees that this project doesn't include any materials (6 materials) or includes less than specified quantities which are regulated by RoHS Compliance.

2. ABSOLUTE MAXIMUM RATINGS

(1) ELECTRICAL ABSOLUTE RATINGS

VSS=0V STANDARD

ITEM	SYMBOL	MIN	MAX	UNIT	COMMENT
Power Supply for Logic	VDD-VSS	-0.3	6.0	V	3X BOOSTING
Power Supply for Logic	VDD-VSS	-0.3	4.5	V	4X BOOSTING
Power Supply for LCM	VDD-V5 VDD-VOUT	-0.3	22.0	V	
Power Supply for LCM	V1,V2,V3,V4	V5	0.3	V	
Input Voltage	VI	-0.3	VDD+0.3	V	
Output Voltage	Vo	-0.3	VDD+0.3	V	
Static Electricity	-	-	-	-	Note 1

Note 1 LCM should be grounded during handling LCM.

(2) ENVIRONMENTAL ABSOLUTE MAXIMUM RATINGS

ITEM	WIDE TEMP.			
	OPERATING		STORAGE	
	MIN.	MAX.	MIN.	MAX.
Ambient Temperature	-20	70	-40	80
Humidity (Without Condensation)	Note 2,4		Note 3,4	

Note 2 $T_a \leq 70^\circ\text{C}$: 75%RH max

Note 3 Please refer to item of reliability test

Note 4 Background color will change slightly depending on ambient temperature.

That phenomenon is reversible.

3. ELECTRICAL CHARACTERISTICS

ITEM	SYMBOL	CONDITION		MIN.	TYP.	MAX.	UNIT
Power Supply for Logic	VDD-VSS	-		4.85	5.0	5.15	V
Input Voltage	VIH	H level		0.8VDD	-	VDD	V
	VIL	L level		0	-	0.2VDD	
Recommended LC Driving Voltage	VDD-V5 (Vop)	Duty= 1/65 Bias= 1/9	-20°C	9.12	9.40	9.68	V
			0°C	8.83	9.10	9.37	
			25°C	8.80	8.90	9.00	
			50°C	8.34	8.60	8.86	
			70°C	7.95	8.20	8.45	
Power Supply Current	IDD	VDD-VSS=5.0V VDD-V5=8.90V Ta=25°C Pattern: <div style="display: flex; flex-wrap: wrap; gap: 5px;"> □■□■□■ ■□■□■□ </div>		-	0.5	1.0	mA

4. OPTICAL CHARACTERISTICS

AT Vop

ITEM		Cr(Contrast Ratio)										θ(Viewing Angle)			φ(Viewing Angle)		
		-20℃		0℃		25℃		50℃		75℃		25℃			25℃		
MODE		MIN.	TYP.	MIN.	TYP.	MIN.	TYP.	MIN.	TYP.	MIN.	TYP.	MIN.	TYP.	MAX.	MIN.	TYP.	MAX.
Z	V	3.0	5.0	4.0	6.0	5.0	7.0	4.0	6.0	2.5	4.0	(F) 33 (R) 23	(F) 40 (R) 30	(F) 47 (R) 37	(R) 28 (L) 28	(R) 35 (L) 35	(R) 42 (L) 42
Note		NOTE 6										NOTE 5					

NOTE :

Z: REFLECTIVE

V: NORMALLY WHITE

AT $\theta=0^\circ$ $\theta=0^\circ$

ITEM	SYMBOL	CONDITION	MIN.	TYP.	MAX.	UNIT	NOTE
Response Time (rise)	Tr	-20℃	3800	4800	7200	ms	NOTE 2
		0℃	350	800	1200		
		25℃	200	250	370		
		50℃	100	120	180		
		70℃	50	65	80		
Response Time (fall)	Tf	-20℃	2400	3000	4500	ms	NOTE 2
		0℃	420	520	780		
		25℃	100	120	180		
		50℃	55	70	105		
		70℃	40	50	75		

(NOTE 1)

Definition of Operation Voltage(Vop)

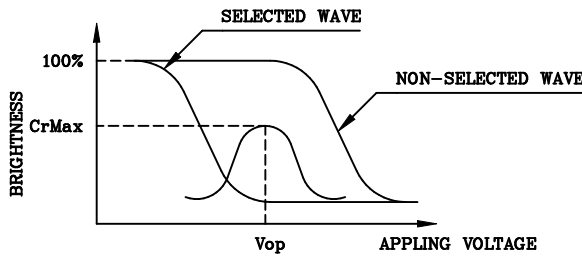

(positive type)

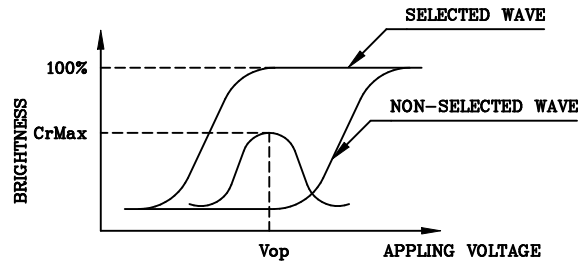

(negative type)

*Conditions

Viewing Angle : 0
Frame Frequency : 70Hz
Applying Waveform : 1/N duty 1/a bias

(NOTE 2)

Definition of Response Time(Tr,Tf)

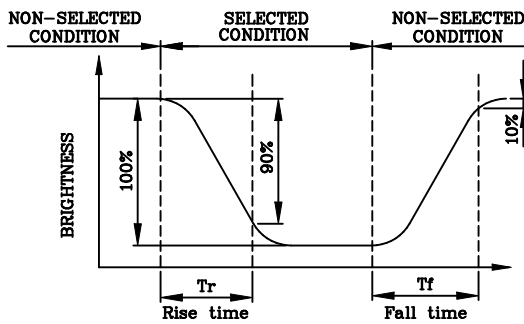

(positive type)

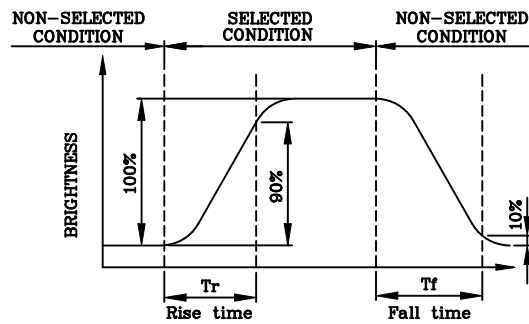

(negative type)

*Conditions

Operating Voltage : Vop
Viewing Angle (θ,φ) : (0,0)
Frame Frequency : 70Hz
Applying Waveform : 1/N duty 1/a bias

(NOTE 3)

Description of Measuring Equipment and Driving Waveforms

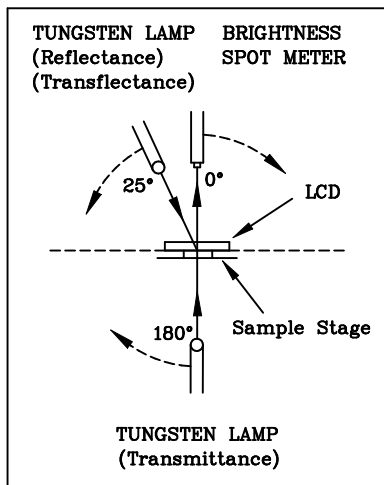

CONST.
TEMP.
CHAMBER

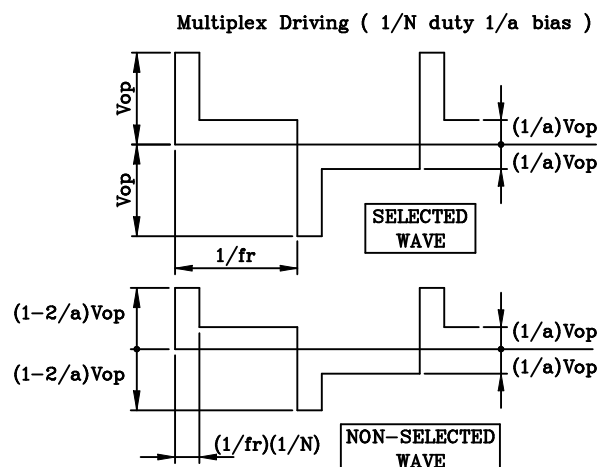

(NOTE 4)

Definition of Viewing Direction

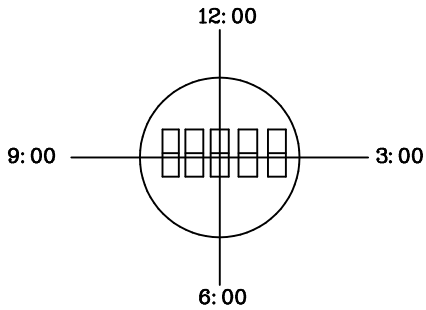

(NOTE 5)

Definition of Viewing Angle

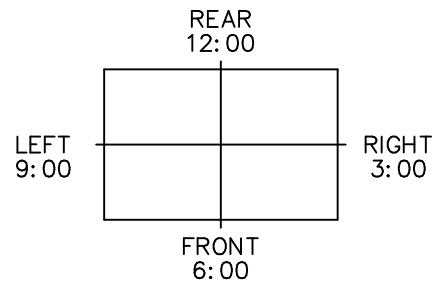
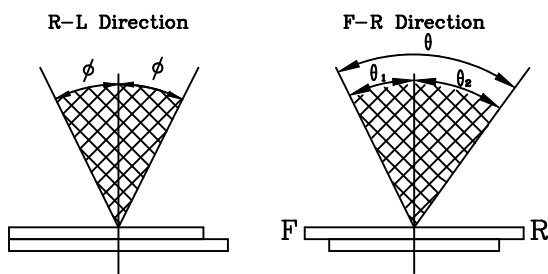

$$\theta = \theta_1 + \theta_2$$

*Conditions

- Operating Voltage : V_{op}
- Frame Frequency : 70Hz
- Applying Waveform : 1/N duty 1/a bias
- Contrast Ratio : larger than 2

(NOTE 6)

Definition of Contrast Ratio (Cr)

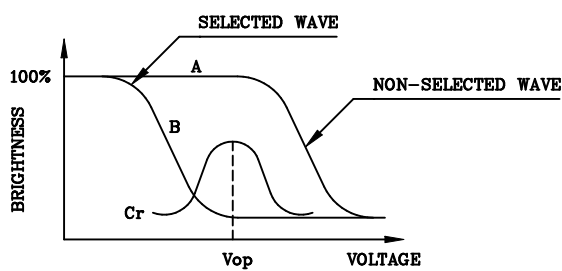

(positive type)

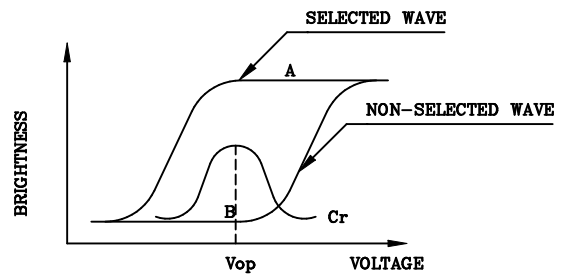

(negative type)

Contrast Ratio : $Cr = A/B$

*Conditions

- Viewing Angle : 0
- Frame Frequency : 70Hz
- Applying Waveform : 1/N duty 1/a bias

5. LOCK DIAGRAM

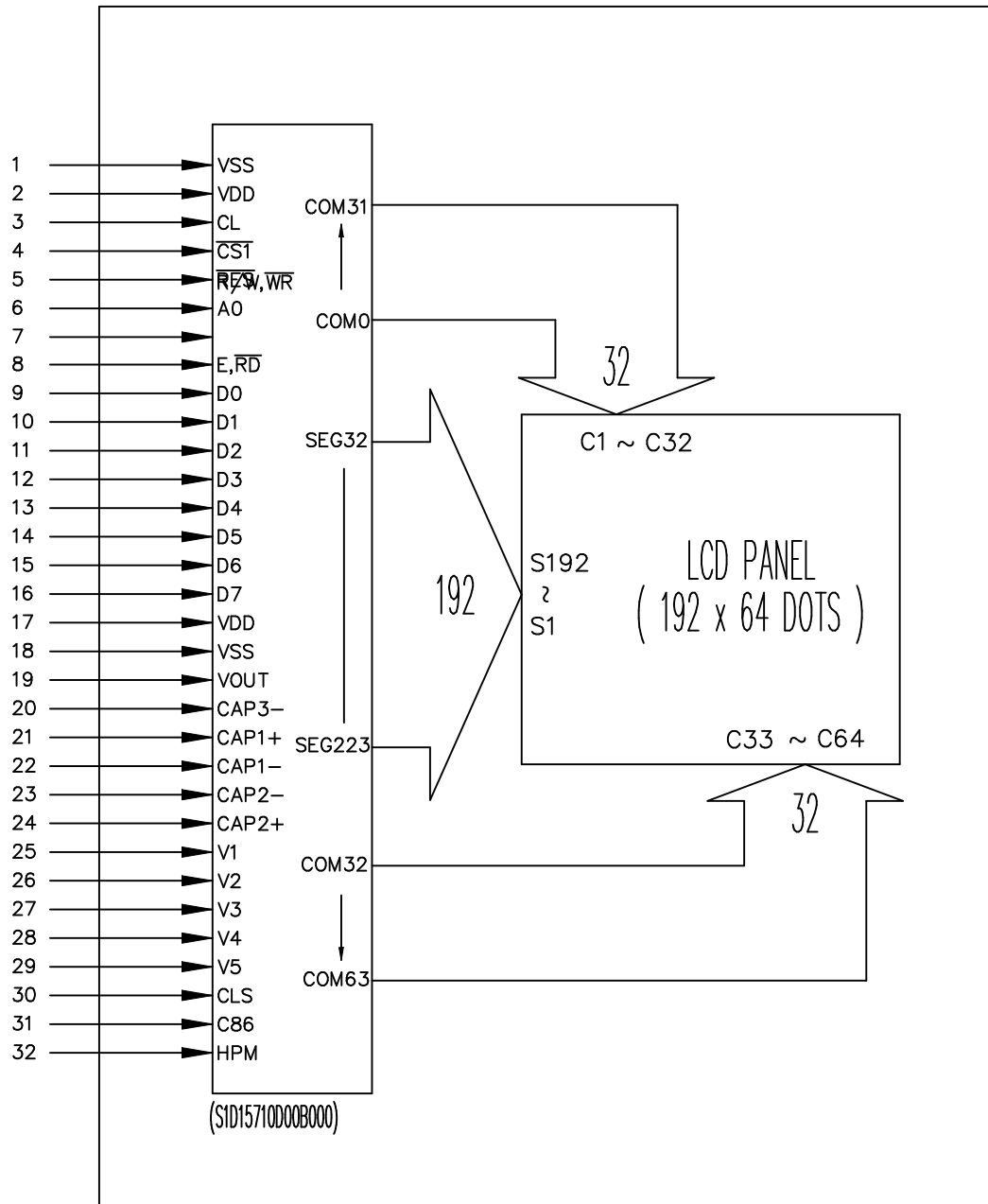

6. INTERNAL PIN CONNECTION

Pin No.	Symbol	Function
1	VSS	Ground
2	VDD	Power Supply Pin
3	CL	Display Clock I/O Pin
4	\overline{CS}	Chip Select Signal
5	\overline{RES}	Reset
6	AO	MCU Interface
7	R/W,WR	
8	E,RD	
9	D0	Data Bus
10	D1	
11	D2	
12	D3	
13	D4	
14	D5	
15	D6	
16	D7	
17	VDD	Power Supply Pin
18	VSS	Ground
19	VOUT	The Most Negative Voltage Supply Pin
20	CAP3-	Internal DC-DC Converter Capacitor
21	CAP1+	
22	CAP1-	
23	CAP2-	
24	CAP2+	
25	V1	The LCD Driving Voltage Levels
26	V2	
27	V3	
28	V4	
29	V5	The Most Negative LCD
30	CLS	Pin That Selects The Validity / Invalidity Of The Built-in Oscillator Circuit For Display Clocks
31	C86	MCU Parallel Interface Selection Input
32	HPM	Power Supply Control Pin Of The Power Supply Circuit For Liquid Crystal Drive

7. POWER SUPPLY

(LCM)

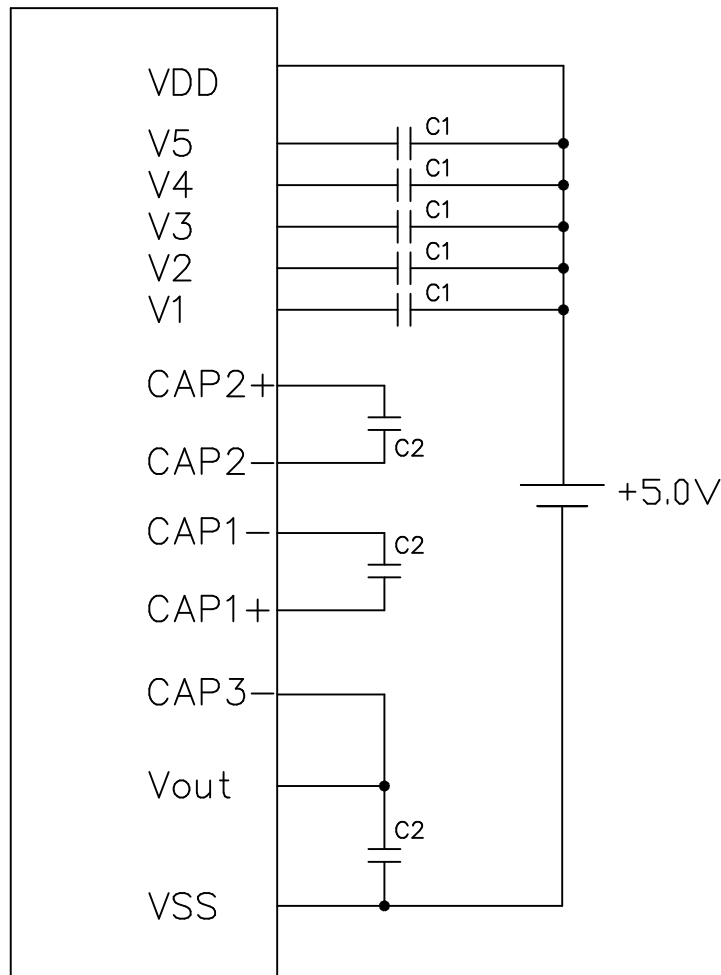

(Note)

C1: $0.01 \mu\text{F} \sim 1 \mu\text{F}$

C2: $1 \mu\text{F} \sim 4.7 \mu\text{F}$

8. TIMING CHARACTERISTICS

(Please refer to EPSON Data Sheet : SED157A Series)

8-2. CONTROL and DISPLAY COMMAND

(Please refer to EPSON Data Sheet : SED157A Series)

9. RELIABILITY TEST

WIDE TEMPERATURE RELIABILITY TEST

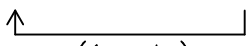
NO	ITEM	CONDITION			STANDARD	NOTE
1	High Temp. Storage	80°C	120Hrs		Appearance without defect	
2	Low Temp. Storage	-40°C	120Hrs		Appearance without defect	
3	High Temp. & High Humi. Storage	60°C 90%RH	120Hrs		Appearance without defect	
4	High Temp. Operating Display	70°C	120Hrs		Appearance without defect	
5	Low Temp. Operating Display	-20°C	120Hrs		Appearance without defect	
6	Thermal Shock	-20°C,30min → 70°C,30min  (1cycle)			Appearance without defect	10 cycles

Inspection Provision

1. Purpose

The NAN YA inspection provision provides outgoing inspection provision and its expected quality level based on our outgoing inspection of NAN YA LCD produces.

2. Applicable Scope

The NAN YA inspection provision is applicable to the arrangement in regard to outgoing inspection and quality assurance after outgoing.

3. Technical Terms

3-1 NAN YA Technical Terms

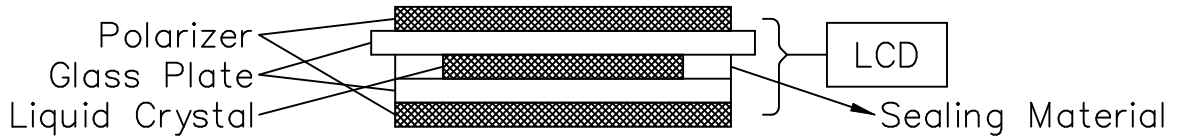

4. Outgoing Inspection

4-1 Inspection Method

MIL-STD-105E Level II Regular inspection

4-2 Inspection Standard

	Item		AQL(%)	Remarks
Major Defect	Dots	Opens Shorts Erroneous operation	0.4	faults which substantially lower the practicality and the initial purpose difficult to achieve.
	Solder appearance	Shorts Loose		
	Cracks	Display surface cracks		

	Dimensions	External from Dimensions	0.4	
Minor Defect	Inside the glass	Black spots	0.65	faults which appear to pose almost no obstacle to the practicality, effective use, and operation.
	Polarizing plate	Scratches, foreign Matter, air bubbles, and peeling		
	Dots	Pinhole, deformation		
	Color tone	Color unevenness		
	Solder appearance	Cold solder Solder projections		

4-3 Inspection Provisions
*Viewing Area Definition

Fig. 1

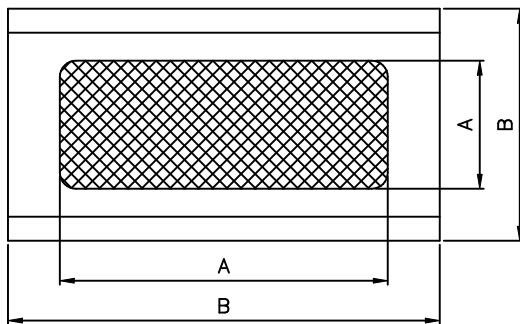

A : Zone Viewing Area
B : Zone Glass Plate Outline

*Inspection place to be 500 to 1000 lux illuminance uniformly without glaring.
The distance between luminous source(daylight fluorescent lamp and cool white fluorescent lamp) and sample to be 30cm to 50cm.

*Test and measurement are performed under the following conditions, unless otherwise specified.

Temperature 20± 15°C
Humidity 65± 20%R.H.
Pressure 860~1060hPa(mmbar)

In case of doubtful judgment, it is performed under the following conditions.

Temperature 20± 2°C
Humidity 65± 5%R.H.
Pressure 860~1060hPa(mmbar)

5.Specification for quality check
5-1 Electrical characteristics

NO.	Item	Criterion
1	Non operational	Fail
2	Miss operating	Fail
3	Missing dot	Fail
4	Contrast irregular	Fail
5	Response time	Within Specified value

5-2 External Appearance Defect

NO.	Item	Criterion																		
1	Black spots, foreign matter, and white spots (Including light leakage due to pinholes of polarizing plates, etc.)	<p>(1)-1-Spots</p> <table border="1" data-bbox="711 477 1356 763"> <thead> <tr> <th>Average Diameter(mm):D</th> <th>Number of pieces permitted</th> </tr> </thead> <tbody> <tr> <td>$D \leq 0.1$</td> <td>Ignore</td> </tr> <tr> <td>$0.1 < D \leq 0.2$</td> <td>5</td> </tr> <tr> <td>$0.2 < D \leq 0.3$</td> <td>2</td> </tr> <tr> <td>$0.3 < D$</td> <td>0</td> </tr> </tbody> </table> <p>Number of total pieces is set to within 5 pieces.</p> <p>Note that when there are 2 pieces or more, they are not to be concentrated. Set as: Average diameter = (Long diameter + Short diameter)/2</p> <p>(1)-2-Blurred Spots(At lighting condition)</p> <table border="1" data-bbox="711 1187 1356 1426"> <thead> <tr> <th>Average Diameter(mm):D</th> <th>Number of pieces permitted</th> </tr> </thead> <tbody> <tr> <td>$D \leq 0.3$</td> <td>Ignore</td> </tr> <tr> <td>$0.3 < D \leq 0.75$</td> <td>5</td> </tr> <tr> <td>$0.75 < D$</td> <td>0</td> </tr> </tbody> </table> <p>Number of total pieces is set to within 5 pieces.</p> <p>Note that when there are 2 pieces or more, they are not to be concentrated. Set as: Average diameter = (Long diameter + Short diameter)/2</p>	Average Diameter(mm):D	Number of pieces permitted	$D \leq 0.1$	Ignore	$0.1 < D \leq 0.2$	5	$0.2 < D \leq 0.3$	2	$0.3 < D$	0	Average Diameter(mm):D	Number of pieces permitted	$D \leq 0.3$	Ignore	$0.3 < D \leq 0.75$	5	$0.75 < D$	0
Average Diameter(mm):D	Number of pieces permitted																			
$D \leq 0.1$	Ignore																			
$0.1 < D \leq 0.2$	5																			
$0.2 < D \leq 0.3$	2																			
$0.3 < D$	0																			
Average Diameter(mm):D	Number of pieces permitted																			
$D \leq 0.3$	Ignore																			
$0.3 < D \leq 0.75$	5																			
$0.75 < D$	0																			

1	Line	<p>(1)-1 Lines</p> <table border="1" data-bbox="710 427 1453 712"> <thead> <tr> <th>Width(mm): W</th> <th>Length(mm): L</th> <th>Number of pieces permitted</th> </tr> </thead> <tbody> <tr> <td>$W \leq 0.03$</td> <td>Ignore</td> <td>Ignore</td> </tr> <tr> <td>$0.03 < W \leq 0.08$</td> <td>$L \leq 4$</td> <td>2</td> </tr> <tr> <td>$0.08 < W \leq 0.1$</td> <td>$L \leq 1$</td> <td>1</td> </tr> </tbody> </table> <p>Object exceeding 0.1mm follow the standards of the spots form. Note that when there are 2 pieces or more, they are not to be concentrated.</p> <p>(1)-2-Blurred Lines(At lighting condition)</p> <table border="1" data-bbox="710 1019 1453 1303"> <thead> <tr> <th>Width(mm): W</th> <th>Length(mm): L</th> <th>Number of pieces permitted</th> </tr> </thead> <tbody> <tr> <td>$W \leq 0.03$</td> <td>Ignore</td> <td>Ignore</td> </tr> <tr> <td>$0.03 < W \leq 0.08$</td> <td>$L \leq 3$</td> <td>6</td> </tr> <tr> <td>$0.08 < W$</td> <td>$3 < L$</td> <td>None</td> </tr> </tbody> </table> <p>Object exceeding 0.1mm follow the standards of the spots form. Note that when there are 2 pieces or more, they are not to be concentrated.</p>	Width(mm): W	Length(mm): L	Number of pieces permitted	$W \leq 0.03$	Ignore	Ignore	$0.03 < W \leq 0.08$	$L \leq 4$	2	$0.08 < W \leq 0.1$	$L \leq 1$	1	Width(mm): W	Length(mm): L	Number of pieces permitted	$W \leq 0.03$	Ignore	Ignore	$0.03 < W \leq 0.08$	$L \leq 3$	6	$0.08 < W$	$3 < L$	None
Width(mm): W	Length(mm): L	Number of pieces permitted																								
$W \leq 0.03$	Ignore	Ignore																								
$0.03 < W \leq 0.08$	$L \leq 4$	2																								
$0.08 < W \leq 0.1$	$L \leq 1$	1																								
Width(mm): W	Length(mm): L	Number of pieces permitted																								
$W \leq 0.03$	Ignore	Ignore																								
$0.03 < W \leq 0.08$	$L \leq 3$	6																								
$0.08 < W$	$3 < L$	None																								
2	Scratches(Glass, reflection plates, and polarizing plates)	In accordance with black spots. (At non lighting condition)																								
3	Color irregular	Not remarkable color irregular.																								

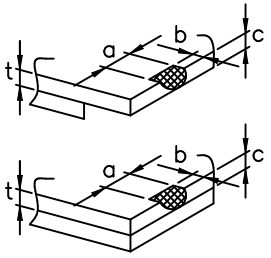
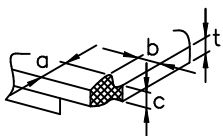
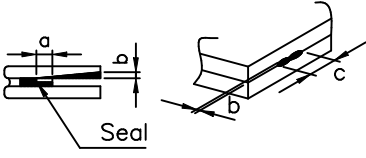
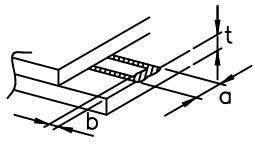
4	Air bubbles polarizing plates, and reflection plates	<table border="1" data-bbox="710 380 1228 672"> <tr> <th data-bbox="710 380 970 526">Average Diameter (mm):D</th> <th data-bbox="970 380 1228 526">Number of pieces permitted</th> <th data-bbox="1228 380 1479 672" rowspan="2">Average diameter = (Long diameter + Short diameter)/2</th> </tr> <tr> <td data-bbox="710 526 970 571">$D \leq 0.3$</td> <td data-bbox="970 526 1228 571">Ignore</td> </tr> <tr> <td data-bbox="710 571 970 672">$0.3 < D$</td> <td data-bbox="970 571 1228 672">0</td> <td></td> </tr> </table> <p data-bbox="710 683 1479 779">Note that when there are 4 pieces or more, they are not to be concentrated.</p>		Average Diameter (mm):D	Number of pieces permitted	Average diameter = (Long diameter + Short diameter)/2	$D \leq 0.3$	Ignore	$0.3 < D$	0	
Average Diameter (mm):D	Number of pieces permitted	Average diameter = (Long diameter + Short diameter)/2									
$D \leq 0.3$	Ignore										
$0.3 < D$	0										
5	Cracks	<p>(1)General crack</p> 	<p>$a \leq 5$ $b \leq 2$ $c \leq t$</p> <p>Where, a and b are ignored when less than or equal to 0.5. The numbers of pieces are set at up to 5 pieces.</p>								
		<p>(2)Corner crack</p> 	<p>$a \leq 2.5$ $b \leq 2.5$ $c \leq t$ $a+b \leq 4$</p>								
		<p>(3)Seal portion crack</p> 	<p>$a \leq \text{The seal width} \times 1/3$ $b \leq t \times 2/3$ $c \leq 5$</p> <p>The numbers of pieces are set at up to 5 pieces.</p>								
		<p>(4)ITO Pin crack</p> 	<p>$a \leq 5$ $b \leq 1/3 \text{ pin length}$ $c \leq t$</p>								
		<p>(5)Progressive cracks</p>	<p>All taken to be unacceptable.</p>								

6	Outer dimensions	Should be within the tolerance.
7	Newton ring(touch panel)	Orbicular of interference fringes is not allowed in the optimum contrast within the active area under viewing angle.
8	Soldering	Should be no defective soldering such as shorting, loose terminal cold solder, peeling of printed circuit board pattern, improper mounting position, etc.

5-3 Dot Appearance Defect

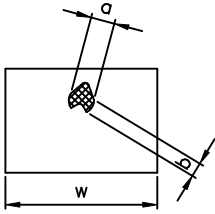
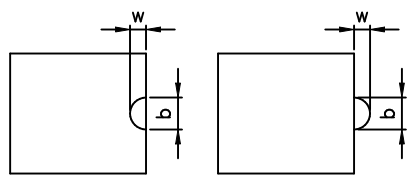
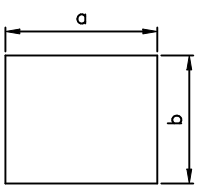
NO.	Item	Criteria
1	Pinhole	 <p>Dot display a and b are each $\leq 0.2\text{mm}$ The overall total is taken be with in 10 units. Note that they are not to be concentrated.</p>
2	Missing	 <p>Dot display a and b are each $\leq 0.2\text{mm}$ The overall total is taken to be with in 10 units.</p>
3	Thick and thin display	 <p>Taken to be within $\pm 1.5\%$ of display character width(a) and height(b).</p>

NOTICE:

- SAFETY

- 1.If the LCD panel breaks, be careful not to get the liquid crystal to touch your skin.
- 2.If the liquid crystal touches your skin or clothes, please wash it off immediately by using soap and water.

- HANDLING

- 1.Avoid static electricity which can damage the CMOS LSI.
- 2.Do not remove the panel or frame from the module.
- 3.The polarizing plate of the display is very fragile. So, please handle it very carefully.
- 4.Do not wipe the polarizing plate with a dry cloth, as it may easily scratch the surface of plate.
- 5.Do not use ketonics solvent & Aromatic solvent. Use a soft cloth soaked with a cleaning naphtha solvent.

- STORAGE

- 1.Store the panel or module in a dark place where the temperature is $25^{\circ}\text{C}\pm 5^{\circ}\text{C}$ and the humidity is below 65% RH.
- 2.Do not place the module near organics solvents or corrosive gases.
- 3.Do not crush, shake, or jolt the module.

- TERMS OF WARRANT

- 1.Acceptance inspection period
The period is within one month after the arrival of contracted commodity at the buyer's factory site.
- 2.Applicable warrant period
The period is within twelve months since the date of shipping out under normal using and storage conditions.

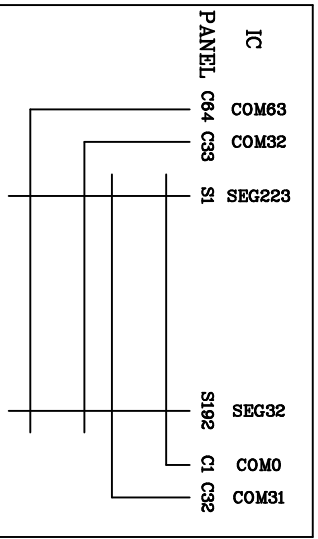
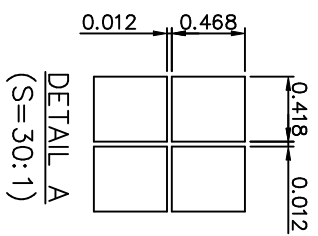
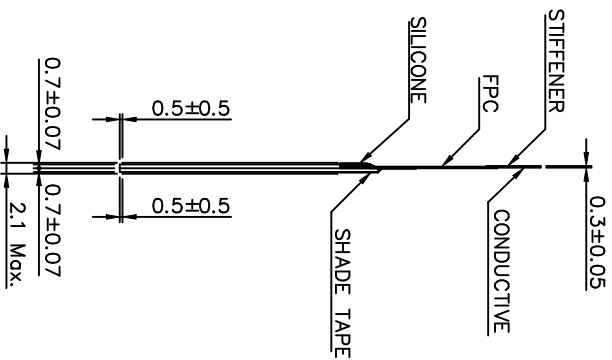
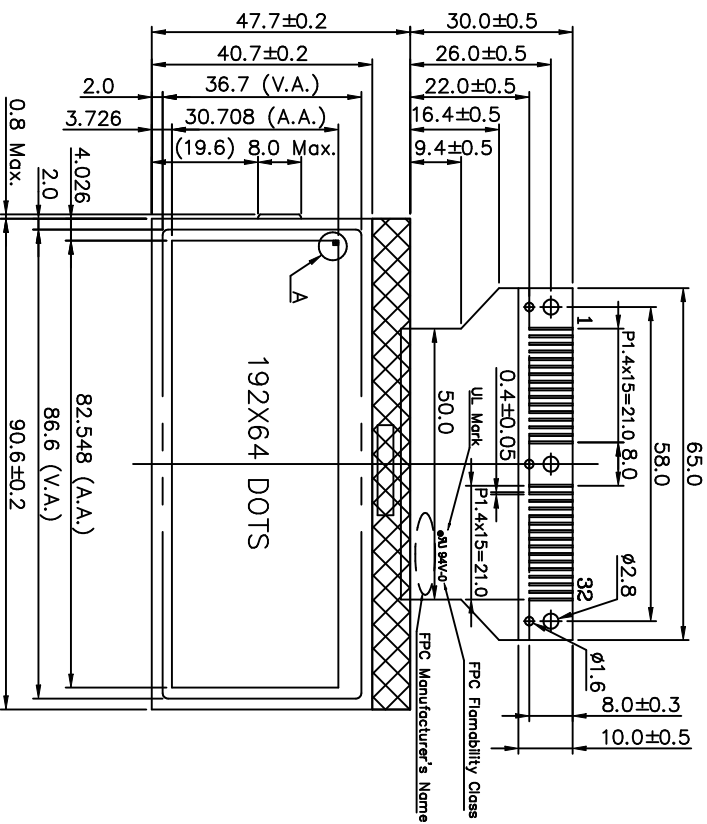

VIEW DIRECTION

Pin No.	Symbol	Function	Pin No.	Symbol	Function
1	VSS	Ground	17	VDD	Power Supply Pin
2	VDD	Power Supply Pin	18	VSS	Ground
3	CL	Display Clock I/O Pin	19	VOU _T	The Most Negative Voltage Supply Pin
4	CS _T	Chip Select Signal	20	CAP ₃₋	Internal DC-DC Converter Capacitor
5	R _{BS}	Reset	21	CAP ₁₊	
6	A ₀		22	CAP ₁₋	
7	R/W, MR, E, RD	MCU Interface	23	CAP ₂₋	The LCD Driving Voltage Levels
8	E, RD		24	CAP ₂₊	
9	D ₀		25	V ₁	
10	D ₁		26	V ₂	
11	D ₂	Data Bus	27	V ₃	
12	D ₃		28	V ₄	
13	D ₄		29	V ₅	
14	D ₅		30	C _{1S}	
15	D ₆		31	C ₈₆	
16	D ₇		32	H _{PM}	

NOTES:

- 1.RESOLUTION: 192X64 DOTS
- 2.BACKLIGHT: NONE
- 3.DRIVER IC: SED157A (Epson)
- 4.NAN YA won't remove shade tape without IMC's agreement

GENERAL TOLERANCE LIST(S)

DIMENSION	TOLERANCE
L ≤ 6	±0.25
6 < L ≤ 18	±0.3
18 < L ≤ 50	±0.4
50 < L ≤ 125	±0.5
125 < L	±0.6

REV. NO.	DESCRIPTION	DATE	DESIGN	CHECK	APPROVE
1					

南亞塑膠工業股份有限公司
NAN YA PLASTICS CORPORATION

製品圖

LDA94Z677VAKS

APPROVE	DATE	THIRD ANGLE P
CHEK		
DESIGN	94.11.14	SCALE UNIT
DRAWN	Campos Chen	94.11.14
		1/1
		mm

THE NOTES OF LCM USING

LCM is easy to damage.

Please follow the notes as bellows, and be careful of handling!

Correct handling

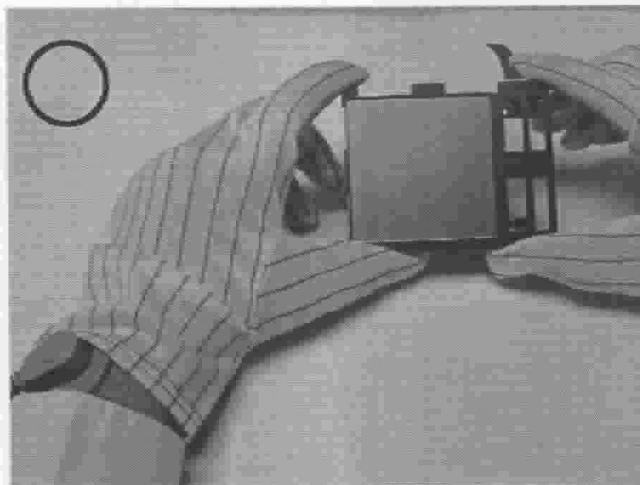
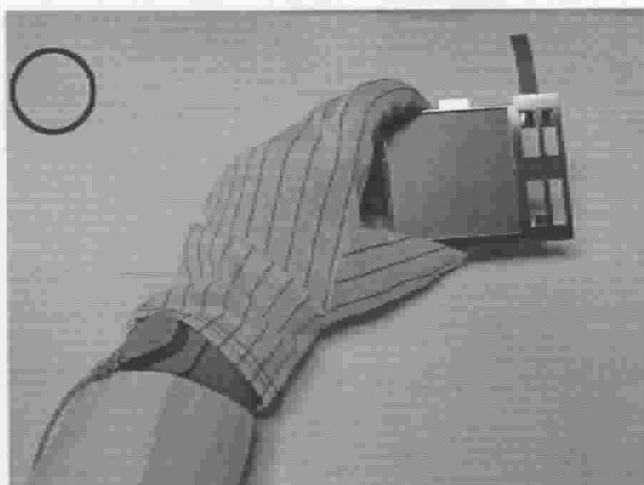

As above picture, please handle with glove by LCM edges and full EOS/ESD protection.

Incorrect handling

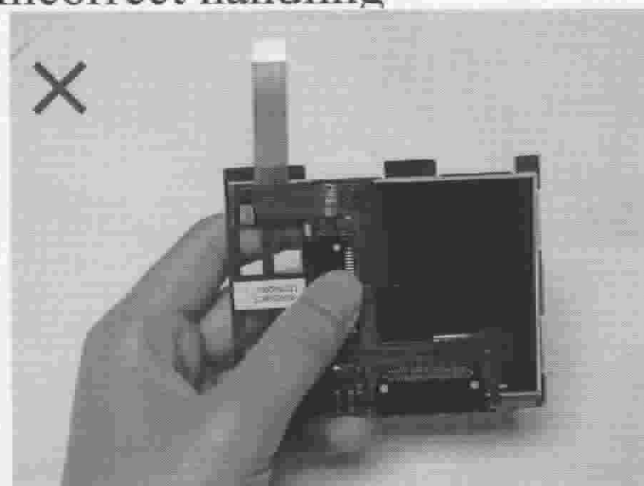

Please don't touch IC directly.

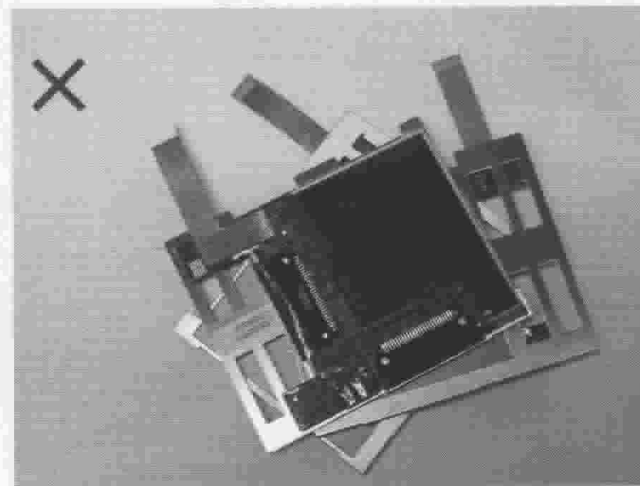

Please don't put one on another LCM.

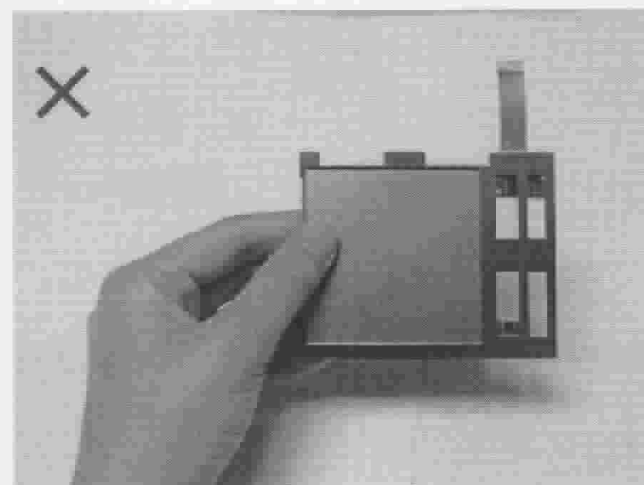

Please don't hold the surface of LCM.

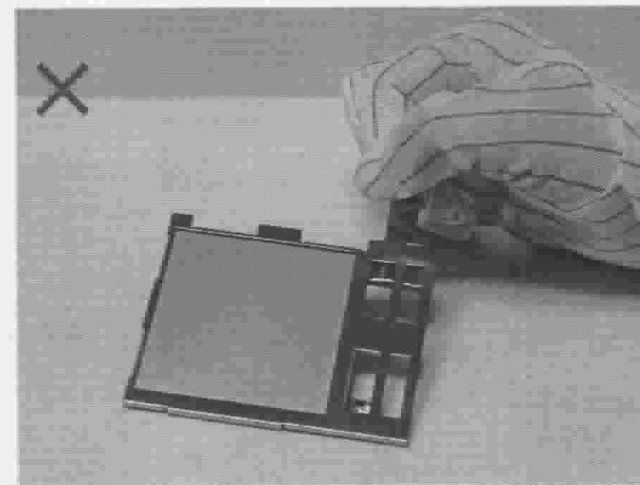

Please don't stretch interface of output.

THE NOTES OF LCD USING

LCD is easy damage.

Please follow notes as bellows, and be careful of handling!

Correct handling

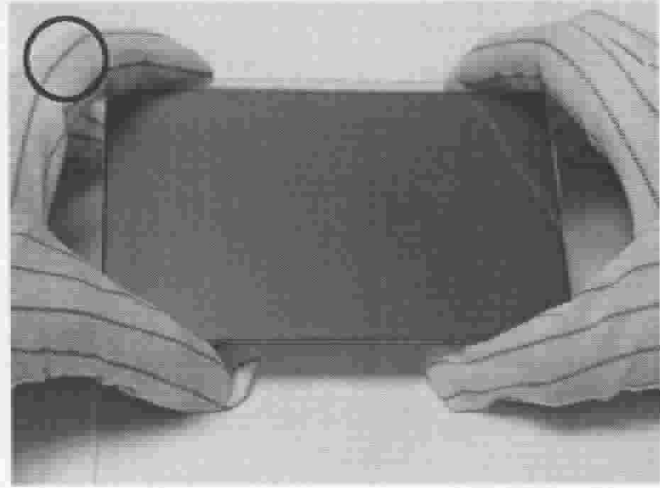
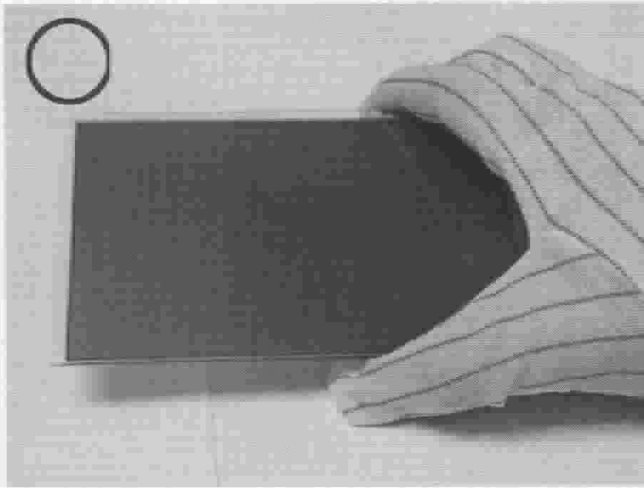

As above picture, please handle with glove by LCD edges and full EOS/ESD protection.

Incorrect handling

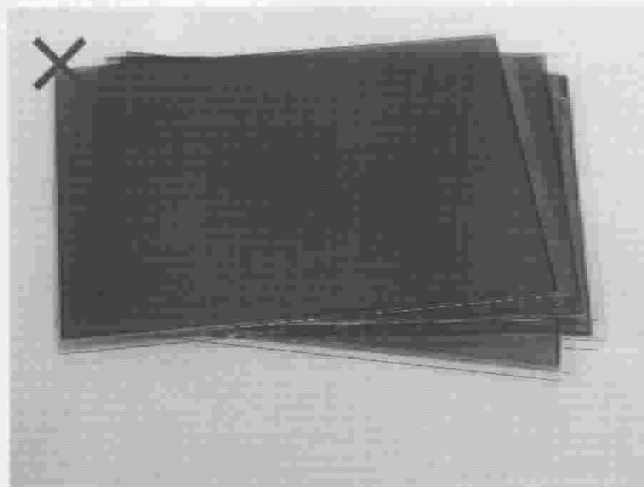

Please don't put one on another LCD.

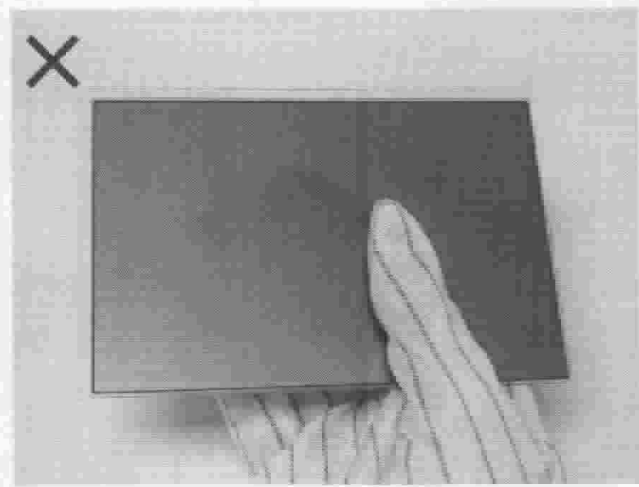

Please don't hold the surface of LCD.

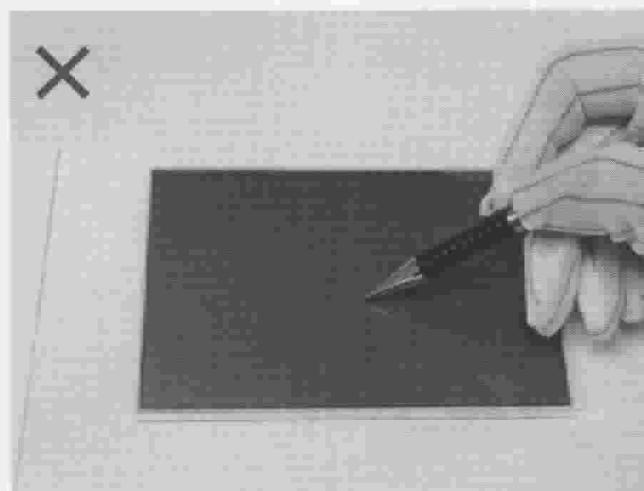

Please don't operate with sharp stick such as sharp pencil.

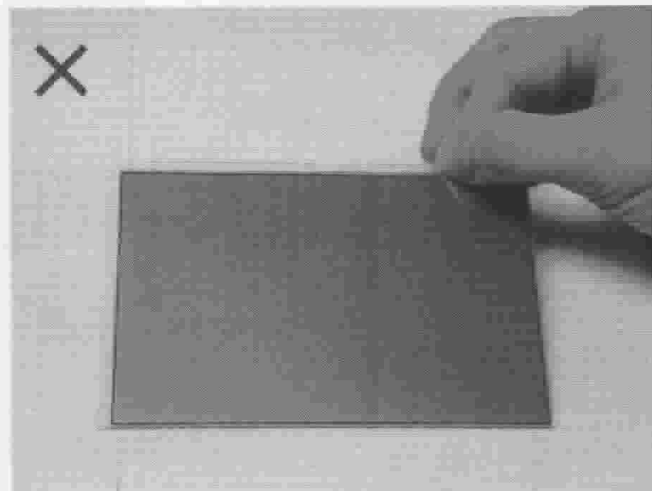

Please don't touch ITO glass without anti-static gloves.

