



# NAN YA PLASTICS CORPORATION

---

SPECIFICATION OF
LCD MODULE
PRODUCT NO. : LTD68M489L5GKS_

SPEC. NO. : LM489-5-0

CUSTOMER
APPROVED BY
DATE:

EDITED ON : Nov. 01, 2007

LCD DEPARTMENT  
ELECTRONIC MATERIALS DIVISION  
NAN YA PLASTICS CORPORATION  
201, TUNG HWA N. ROAD, TAIPEI  
TEL:886-2-27122211 EXT. 5993~5995  
FAX:886-2-27178253  
E-mail:lcdsales@npc.com.tw

Q.C. DEPT.	DESIGN MANAGER	DESIGN CHECK	DESIGNER
			W.R.HSU



NAN YA PLASTICS CORP. ELEC. MATERIALS DIV. LCD DEPARTMENT	SPECIFICATION	SPEC. NO. : LM489-5 DATE : Nov. 01, 2007 SHEET NO. : 1
---	---------------	--

## 1.MECHANICAL DATA

NO.	ITEM	CONTENTS	UNIT
1	Product No.	LTD68M489L5GKS_	—
2	Module Size	61.2 (W) x 83.0 (H) x MAX. 4.2(D)	mm
3	Dot Size	0.20 (W) x 0.20 (H)	mm
4	Dot Pitch	0.21 (W) x 0.21 (H)	mm
5	Number of Dots	240 (W) x 320 (H)	Dot
6	Duty	1/240	—
7	LCD Display Mode	FSTN, Normally White / Positive Image	—
8	Rear Polarizer	Transflective Type	—
9	Viewing Direction	6	O'clock
10	Backlight	EL	—
11	Controller	Excluded	—
12	DC/DC Converter	Excluded	—
13	Touch Panel	Excluded	—
14	Weight	55 (Approx.)	g

NOTE:

L T D 6 8 M 4 8 9 L 5 G K S  
 (1) (2) (3) (4) (5) (6) (7) (8)

NO.	ITEM	SYMBOL	DEFINITION
(1)	Backlight	D	EL Backlight
(2)	Reflective/Transmissive	M	Transflective
(3)	Mode/View Angle	L	Normally White, 6 O'clock
(4)	Option	5	Module Version Number
(5)		G	Specially Color Backlight
(6)		K	High Contrast Ratio LC
(7)		S	RoHS Compliance
(8)		T	Testing Sample

Nan Ya guarantees that this project doesn't include  
 any materials (6 materials) or includes less than specified  
 quantities which are regulated by RoHS Compliance.

REV/DATE	R0/ 11.01.07'						BY W.R.HSU
----------	------------------	--	--	--	--	--	---------------

NAN YA PLASTICS CORP. ELEC. MATERIALS DIV. LCD DEPARTMENT	SPECIFICATION	SPEC. NO. : LM489-5 DATE : Nov. 01, 2007 SHEET NO. : 2
---	---------------	--

## 2.ABSOLUTE MAXIMUM RATINGS

### 2-1.ELECTRICAL ABSOLUTE RATINGS

VSS=0V

ITEM	SYMBOL	MIN.	MAX.	UNIT	COMMENT
Power Supply for Logic	VDD-VSS	-0.3	5.5	V	Note 1
Power Supply for LCD Drive	VH-VSS	-0.3	25	V	
	VM-VSS	-0.3	5	V	
Static Electricity	—	—	—	—	Note 2

Note 1 All voltage values are referred to VSS=0V.

Note 2 Make certain you are GROUNDED when handling LCM.

### 2-2.ENVIRONMENTAL ABSOLUTE MAXIMUM RATINGS

ITEM	WIDE TEMP.			
	OPERATING		STORAGE	
	MIN.	MAX.	MIN.	MAX.
Ambient Temperature(°C)	-20	70	-40	80
Humidity (Without Condensation)	Note 3,5		Note 4,5	

Note 3  $T_a \leq 70^\circ\text{C}$  : 75%RH MAX.

Note 4 Please refer to item of reliability test.

Note 5 Background color will change slightly depending on ambient temperature.  
That phenomenon is reversible.

REV/DATE	R0/ 11.01.07'						BY W.R.HSU
----------	------------------	--	--	--	--	--	---------------

NAN YA PLASTICS CORP. ELEC. MATERIALS DIV. LCD DEPARTMENT	SPECIFICATION	SPEC. NO. : LM489-5 DATE : Nov. 01, 2007 SHEET NO. : 3-1
---	---------------	--

### 3.ELECTRICAL CHARACTERISTICS

#### 3-1.ELECTRICAL CHARACTERISTICS OF LCM

ITEM	SYMBOL	CONDITION	MIN.	TYP.	MAX.	UNIT	
Power Supply for Logic	VDD-VSS	—	3.0	3.3	3.6	V	
Input Voltage	VIH	H Level	0.8VDD	—	VDD	V	
	VIL	L Level	0	—	0.2VDD		
Recommended LC Driving Voltage	VH-VSS (Vop)	Duty = 1/240 Bias=1/13	-20°C	19.9	20.3	20.7	V
			0°C	18.7	19.1	19.5	
			25°C	18.0	18.4	18.8	
			50°C	17.3	17.7	18.1	
			70°C	16.6	17.0	17.4	
Power Supply Current (Ta=25°C)	IDD	VDD-VSS=3.3V VH-VSS=18.4V FLM=70Hz	—	0.5	1.0	mA	
	IH	Pattern: 	—	0.1	0.2		
LCM Surface Luminance (Ta=25°C)	L	VDD-VSS = 3.3V VH-VSS=18.4V VEL=65 Vrms 250 Hz	Dots All On (White)	2	4	—	cd/m <sup>2</sup>
			Dots All Off (Black)	—	0.5	—	
SWITCH SIGNAL TO CONVERT LCD DRIVE WAVEFORM INTO AC	DF	—	—	35	—	Hz	

REV/DATE	R0/ 11.01.07'						BY W.R.HSU
----------	------------------	--	--	--	--	--	---------------

NAN YA PLASTICS CORP. ELEC. MATERIALS DIV. LCD DEPARTMENT	SPECIFICATION	SPEC. NO. : LM489-5 DATE : Nov. 01, 2007 SHEET NO. : 3-2
---	---------------	--

### 3-2.ELECTRICAL CHARACTERISTICS OF BACKLIGH'

Used EL Rating

Ta=25°C

ITEM	SYMBOL	MIN.	TYP.	MAX.	UNIT	REMARK
Maximum applied voltage	VL	—	—	150	Vrms	—
Maximum applied frequency	FL	—	—	1000	Hz	—
EL current	IL	—	2.3	3.1	mArms	at 65 Vrms 250 Hz
EL power consumption	PL	—	0.15	—	W	(*1)
EL life time	LL	—	2000	—	Hrs	at 65 Vrms 250 Hz (*2)

(\*1) Power consumption excluded inverter loss.

(\*2) EL life time is defined as follows : The final brightness is at 50% of original brightness .

REV/DATE	R0/ 11.01.07'							BY	W.R.HSU
----------	------------------	--	--	--	--	--	--	----	---------

NAN YA PLASTICS CORP. ELEC. MATERIALS DIV. LCD DEPARTMENT	SPECIFICATION	SPEC. NO. : LM489-5 DATE : Nov. 01, 2007 SHEET NO. : 4-1
---	---------------	--

## 4.OPTICAL CHARACTERISTICS

4-1.Optical Char. of Normal Temp. Mode

at Vop

ITEM		Cr(Contrast Ratio)										$\theta$ (Viewing Angle)		$\varphi$ (Viewing Angle)	
		-20℃		0℃		25℃		50℃		70℃		25℃		25℃	
MODE		MIN.	TYP.	MIN.	TYP.	MIN.	TYP.	MIN.	TYP.	MIN.	TYP.	Viewing Direction	TYP.	Viewing Direction	TYP.
		M	L	3.5	5	4	5.5	4.5	6	3	4	2	3	6 O'Clock	45
												12 O'Clock	35	3 O'Clock	40
NOTE		NOTE 3,6										NOTE 3,5			

NOTE :

M : Transflective

L : Normally White, 6 O'clock

at  $\varphi = 0^\circ, \theta = 0^\circ$

ITEM	SYMBOL	CONDITION	MIN.	TYP.	MAX.	UNIT	NOTE
Response Time (rise)	Tr	-20℃	2000	2500	3750	ms	NOTE 2,3
		0℃	500	620	930		
		25℃	160	200	300		
		50℃	70	80	120		
		70℃	70	90	140		
Response Time (fall)	Tf	-20℃	7200	9000	13500	ms	NOTE 2,3
		0℃	1150	1400	2100		
		25℃	300	370	560		
		50℃	160	200	300		
		70℃	80	100	150		

REV/DATE	R0/ 11.01.07'						BY W.R.HSU
----------	------------------	--	--	--	--	--	---------------

(NOTE 1)

Definition of Operation Voltage(Vop)

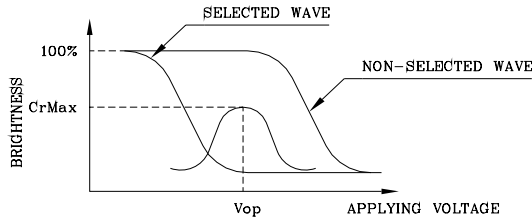

(positive type)

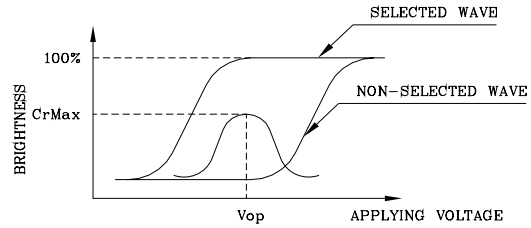

(negative type)

\*Conditions

Viewing Angle : 0  
Frame Frequency : 70Hz  
Applying Waveform : 1/N duty 1/a bias

(NOTE 2)

Definition of Response Time(Tr,Tf)

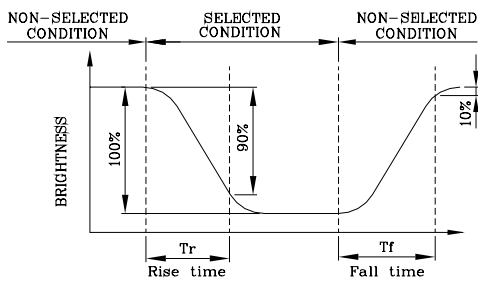

(positive type)

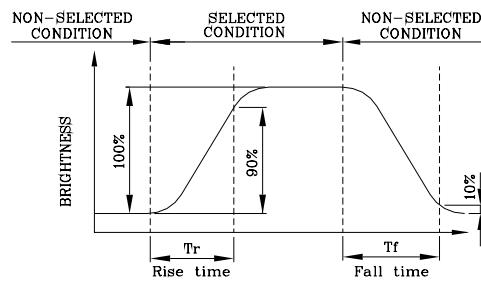

(negative type)

\*Conditions

Operating Voltage : Vop  
Viewing Angle ( $\theta, \theta$ ) : (0,0)  
Frame Frequency : 70Hz  
Applying Waveform : 1/N duty 1/a bias

(NOTE 3)

Description of Measuring Equipment and Driving Waveforms

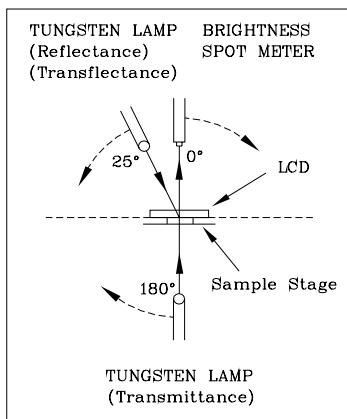

CONST.  
TEMP.  
CHAMBER

The voltage relationship of each signal is as follow  
Multiplex Driving (1/N duty 1/a bias)

Segment voltage	Segment Waveform	Common Waveform	Common voltage
V0	[Square wave]	[Square wave]	VH
VM			VM
V1	[Square wave]	[Square wave]	VL
	Normally display period	Off-display period	

(NOTE 4)

Definition of Viewing Direction

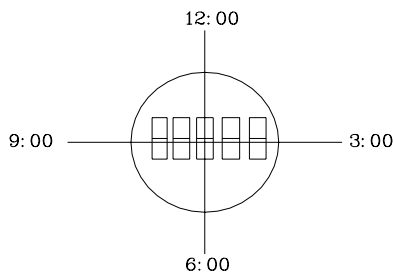

(NOTE 5)

Definition of Viewing Angle

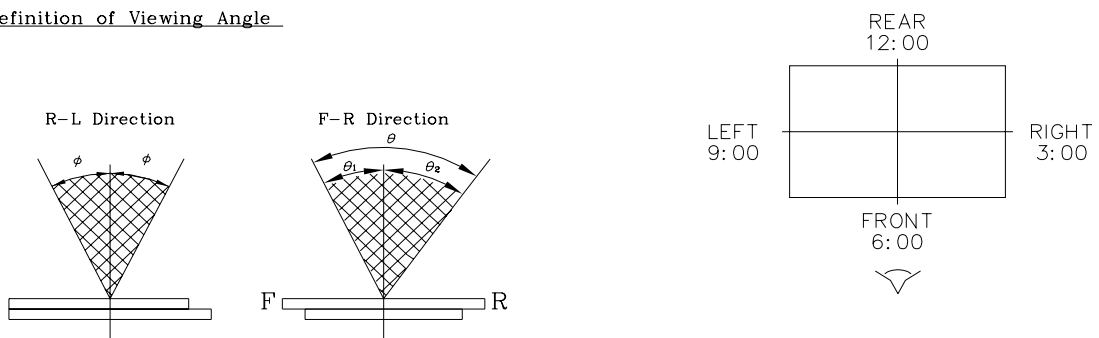

$$\theta = \theta_1 + \theta_2$$

\*Conditions

Operating Voltage :  $V_{op}$   
 Frame Frequency : 70Hz  
 Applying Waveform : 1/N duty 1/a bias  
 Contrast Ratio : larger than 2

(NOTE 6)

Definition of Contrast Ratio (Cr)

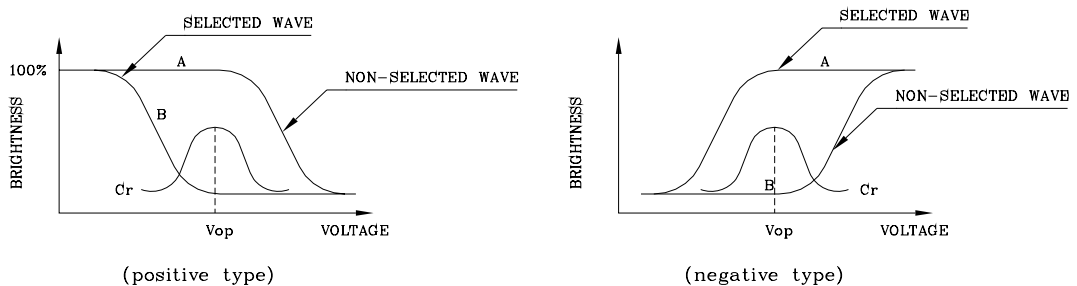

$$\text{Contrast Ratio : } Cr = A/B$$

\*Conditions

Viewing Angle : 0  
 Frame Frequency : 70Hz  
 Applying Waveform : 1/N duty 1/a bias

REV/DATE	R0/ 11.01.07'						BY W.R.HSU
----------	------------------	--	--	--	--	--	---------------

5. BLOCK DIAGRAM

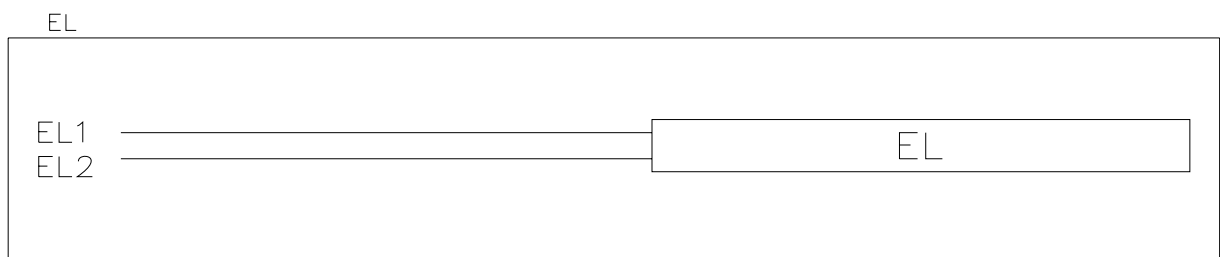
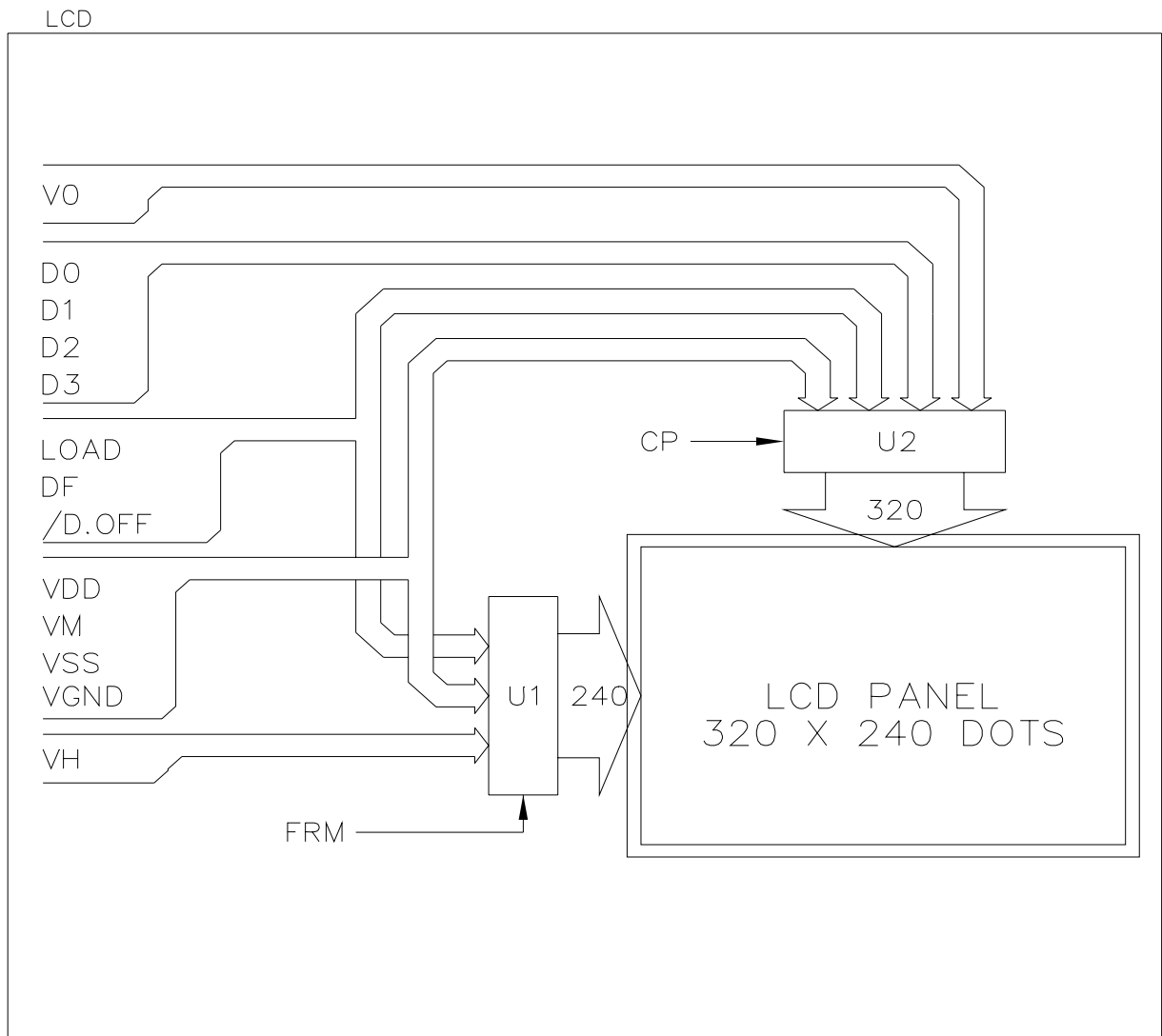

REV/DATE	R0/ 11.01.07'						BY W.R.HSU
----------	------------------	--	--	--	--	--	---------------

## 6.INTERNAL PIN CONNECTION

LCD

Pin No.	Symbol	Function
1	NC	NO CONNECTION
2	NC	NO CONNECTION
3	NC	NO CONNECTION
4	NC	NO CONNECTION
5	NC	NO CONNECTION
6	NC	NO CONNECTION
7	NC	NO CONNECTION
8	NC	NO CONNECTION
9	VSS	GND
10	NC	NO CONNECTION
11	VH	LCD SELECTED LEVEL POWER SUPPLY FOR COMMON
12	NC	NO CONNECTION
13	VDD	POWER SUPPLY FOR LOGIC(+3.3V)
14	FRM	FRAME START SIGNAL
15	VGND	GND,POWER SUPPLY FOR LCD
16	LOAD	1.LATCH PULSE OF DISPLAY DATA 2.SHIFT CLOCK FOR COMMON DRIVER
17	VSS	GND
18	DF	SWITCH SIGNAL TO CONVERT LCD DRIVE WAVEFORM INTO AC
19	/D.OFF	H : DISPLAY ON , L : DISPLAY OFF
20	CP	CLOCK PULSE FOR SEGMENT SHIFT REGISTER
21	VM	LCD NON-SELECTED LEVEL POWER SUPPLY FOR COMMON AND SEGMENT
22	V0	LCD SELECTED LEVEL POWER SUPPLY FOR SEGMENT
23	D3	INPUT DATA SIGNAL
24	D2	INPUT DATA SIGNAL
25	D1	INPUT DATA SIGNAL
26	D0	INPUT DATA SIGNAL
27	VSS	GND
28	NC	NO CONNECTION
29	EL1	EL(-)
30	EL2	EL(+)

USED LCD INTERFACE CABLE :

FPC,N30,Pitch 0.5 mm (Thickness = 0.3 mm)

CORRESPONDABLE LCD CONNECTOR :

MOLEX 52689-3087 or COMPATIBLE

REV/DATE	R0/ 11.01.07'						BY W.R.HSU
----------	------------------	--	--	--	--	--	---------------

7.POWER SUPPLY

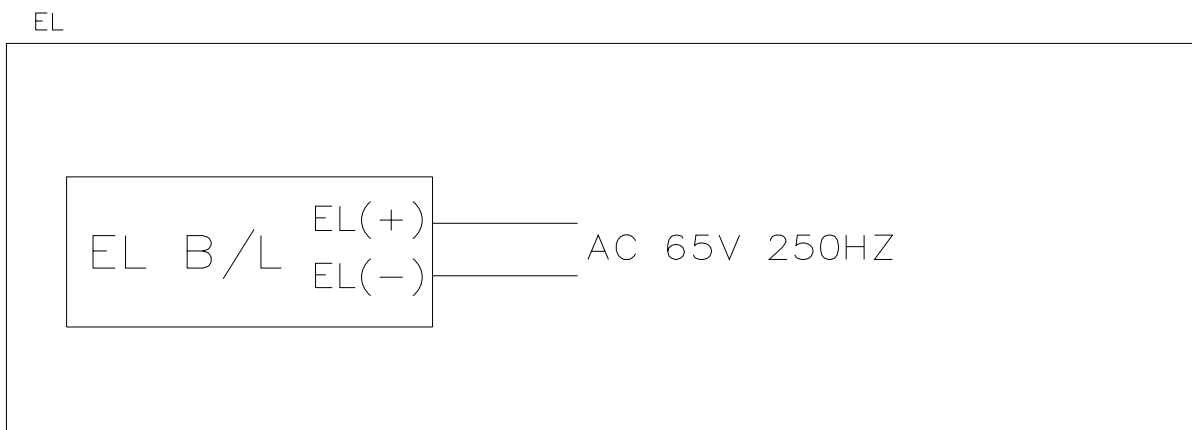
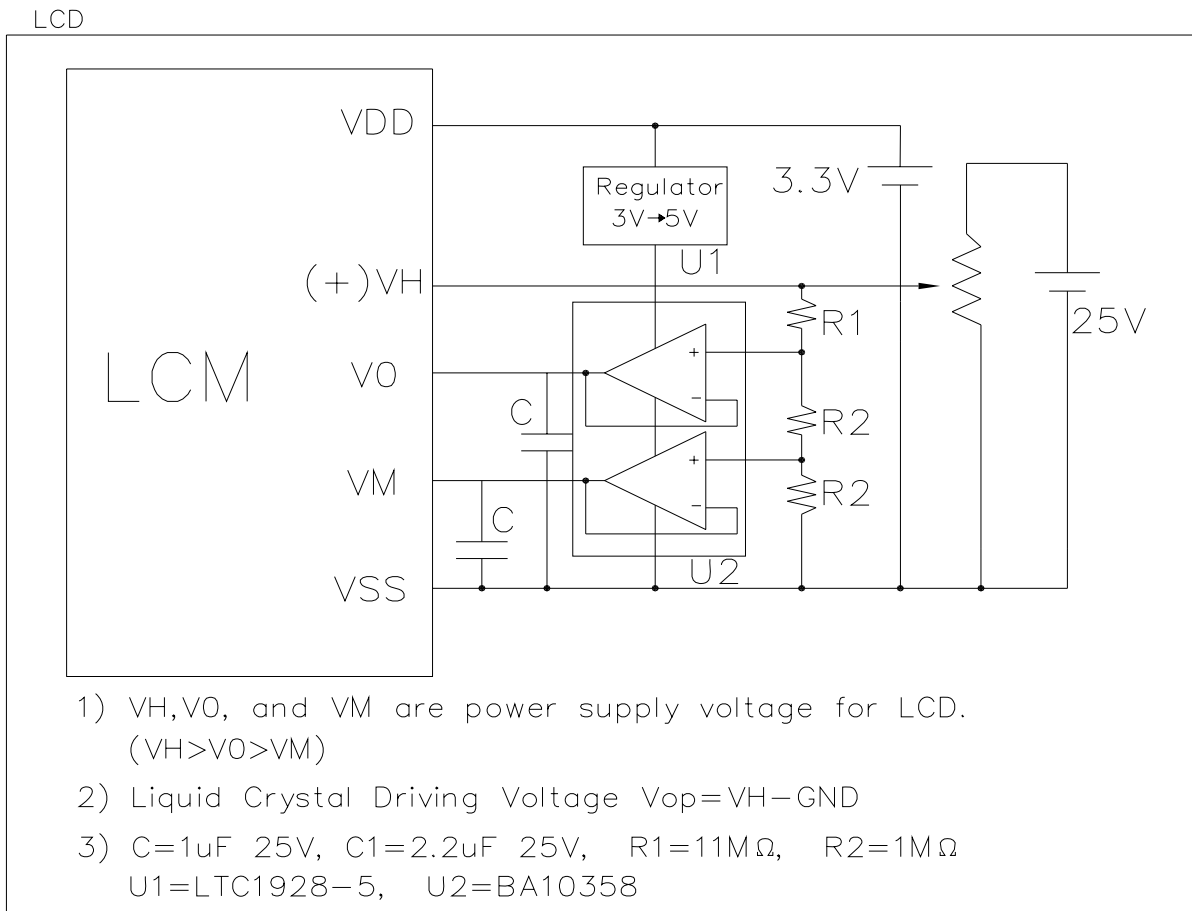

## 8.TIMING CHARACTERISTICS

### 8-1.INTERFACE TIMING

© VDD=3.3V±10%, Ta=-20~70°C

Item	Symbol	Test condition	Min.	Typ.	Max.	Unit
CP Clock Cycle	tCYC2	Fig.a	152	-	-	ns
CP HIGH-LEVEL Width	tCWH2	Fig.a	65	-	-	ns
CP LOW-LEVEL Width	tCWL2	Fig.a	65	-	-	ns
Data Set Up Time	tDS2	Fig.a	50	-	-	ns
Data Hold Time	tDH2	Fig.a	50	-	-	ns
CP Rise/Fall Time	tr2,tf2	Fig.a	-	-	30	ns
Clock Set Up Time	tSCL	Fig.a	80	-	-	ns
Clock Hold Time	tHCL	Fig.a	80	-	-	ns
DF Set Up Time	tMS	Fig.a	20	-	-	ns
DF Hold Time	tMH	Fig.a	20	-	-	ns

© VDD=3.3V±10%, Ta=-20~70°C

Item	Symbol	Test condition	Min.	Typ.	Max.	Unit
LOAD Clock Cycle	tCYC1	Fig.b	400	-	-	ns
LOAD HIGH-LEVEL Width	tCWH1	Fig.b	25	-	-	ns
LOAD LOW-LEVEL Width	tCWL1	Fig.b	370	-	-	ns
Data Set Up Time	tDS1	Fig.b	100	-	-	ns
Data Hold Time	tDH1	Fig.b	10	-	-	ns
LOAD Rise/Fall Time	tr1,tf1	Fig.b	-	-	30	ns

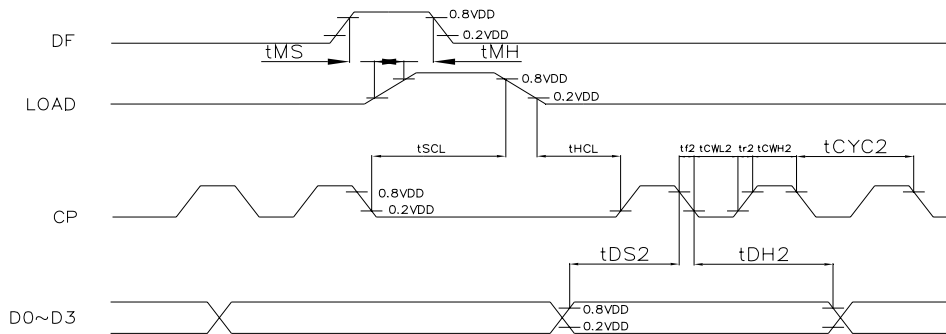

Fig . a Interface timing (SEGMENT)

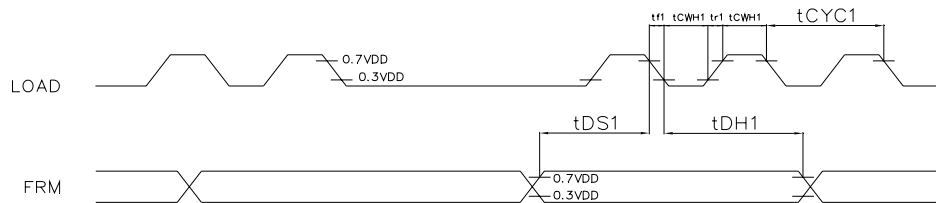
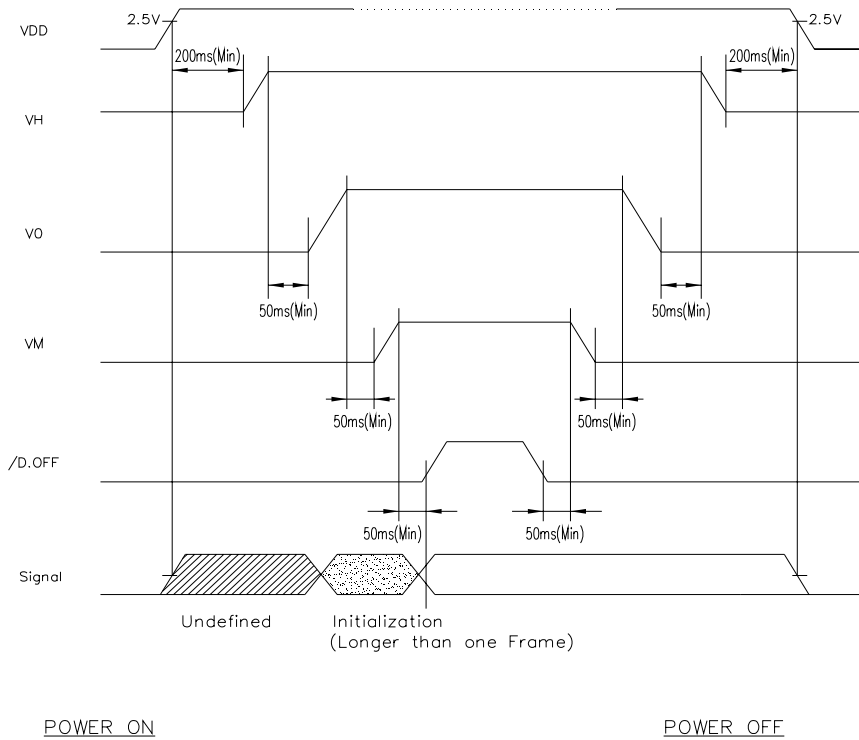

Fig . b Interface timing (COMMON)

8-2.POWER ON/OFF TIMING



The missing pixels may occur when the LCM is driven beyond above power interface timing sequence.

REV/DATE	R0/ 11.01.07'						BY W.R.HSU
----------	------------------	--	--	--	--	--	---------------

8-3.DISPLAY PATTERN

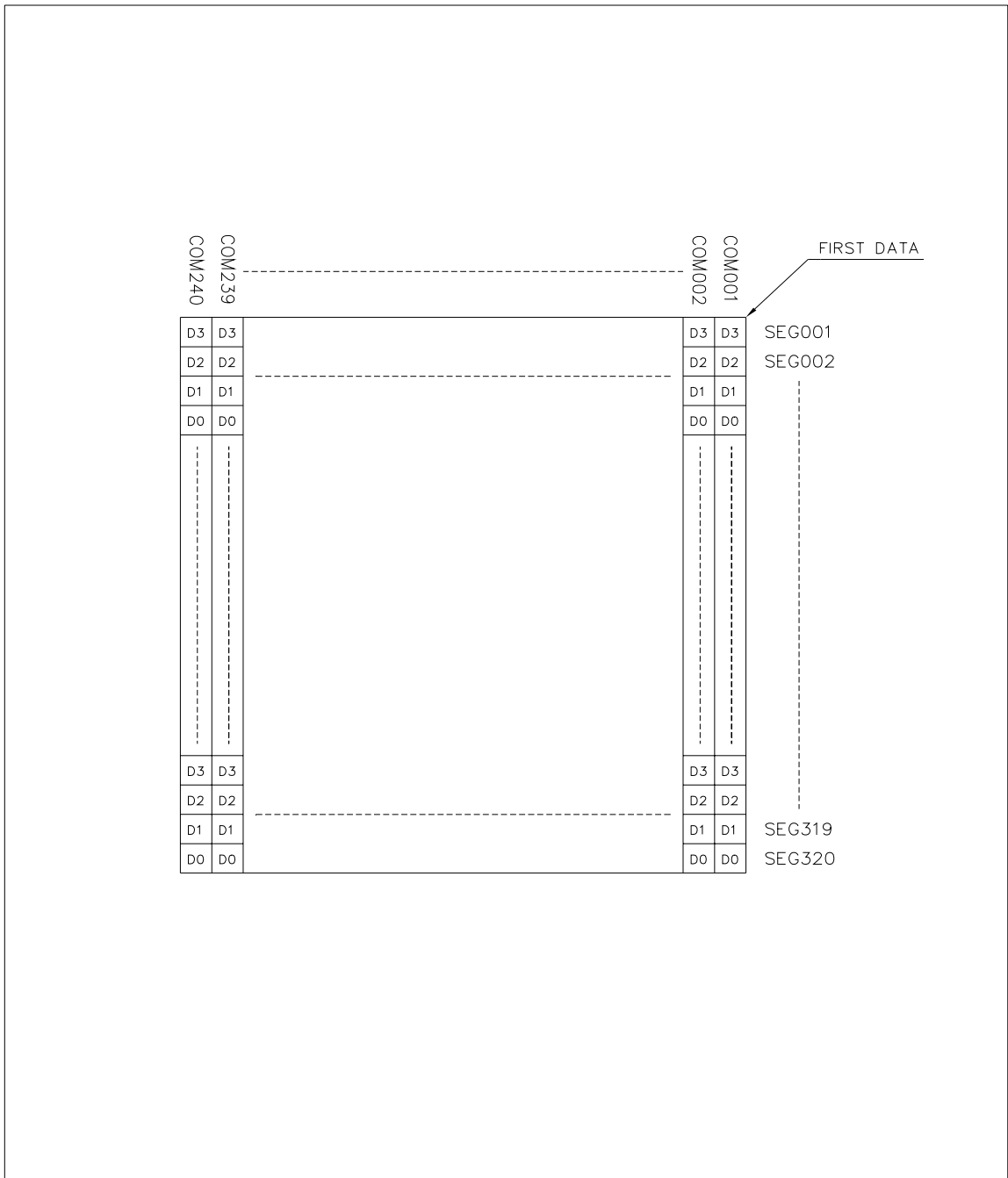

NAN YA PLASTICS CORP. ELEC. MATERIALS DIV. LCD DEPARTMENT	SPECIFICATION	SPEC. NO. : LM489-5 DATE : Nov. 01, 2007 SHEET NO. : 9-1
---	---------------	--

## 9.RELIABILITY TEST

### WIDE TEMPERATURE RELIABILITY TEST

NO.	ITEM	CONDITION			STANDARD	NOTE
1	High Temp. Storage	80 °C	120 Hrs		Appearance without defect	
2	Low Temp. Storage	-40 °C	120 Hrs		Appearance without defect	
3	High Temp. & High Humi. Storage	60 °C 90%RH	120 Hrs		Appearance without defect	
4	High Temp. Operating Display	70 °C	120 Hrs		Appearance without defect	
5	Low Temp. Operating Display	-20 °C	120 Hrs		Appearance without defect	
6	Thermal Shock	-20 °C, 30min. → 70°C, 30min. ↑ (1cycle) ↓			Appearance without defect	10 cycles

REV/DATE	R0/ 11.01.07'							BY	W.R.HSU
----------	------------------	--	--	--	--	--	--	----	---------

NAN YA PLASTICS CORP. ELEC. MATERIALS DIV. LCD DEPARTMENT	<b>SPECIFICATION</b>	SPEC. NO. : LM489-5 DATE : Nov. 01, 2007 SHEET NO. : 9-2
---	----------------------	--

Inspection Provision

1.Purpose

The NAN YA inspection provision provides outgoing inspection provision and its expected quality level based on our outgoing inspection of NAN YA LCD produces.

2.Applicable Scope

The NAN YA inspection provision is applicable to the arrangement in regard to outgoing inspection and quality assurance after outgoing.

3.Technical Terms

3-1 NAN YA Technical Terms



4.Outgoing Inspection

4-1 Inspection Method

MIL-STD-105E Level II Regular inspection

4-2 Inspection Standard

	Item		AQL(%)	Remarks
Major Defect	Dots	Opens	0.4	faults which substantially lower the practicality and the initial purpose difficult to achieve.
		Shorts		
	Erroneous operation			
Solder appearance	Shorts			
	Loose			
Cracks	Display surface cracks			

REV/DATE	R0/ 11.01.07'							BY	W.R.HSU
----------	------------------	--	--	--	--	--	--	----	---------

NAN YA PLASTICS CORP. ELEC. MATERIALS DIV. LCD DEPARTMENT	<b>SPECIFICATION</b>	SPEC. NO. : LM489-5 DATE : Nov. 01, 2007 SHEET NO. : 9-3
---	----------------------	--

	Dimensions	External from Dimensions	0.4	
Minor Defect	Inside the glass	Black spots	0.65	faults which appear to pose almost no obstacle to the practicality, effective use, and operation.
	Polarizing plate	Scratches, foreign Matter, air bubbles, and peeling		
	Dots	Pinhole, deformation		
	Color tone	Color unevenness		
	Solder appearance	Cold solder Solder projections		

4-3 Inspection Provisions

\*Viewing Area Definition

Fig. 1

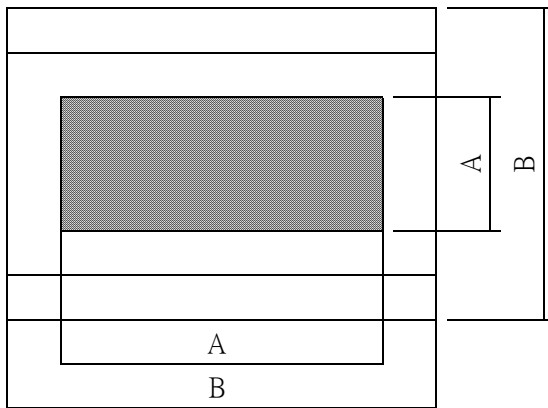

A : Zone Viewing Area  
 B : Zone Glass Plate Outline

\*Inspection place to be 500 to 1000 lux illuminance uniformly without glaring.  
 The distance between luminous source(daylight fluorescent lamp and cool white fluorescent lamp) and sample to be 30 cm to 50 cm.

REV/DATE	R0/ 11.01.07'							BY	W.R.HSU
----------	------------------	--	--	--	--	--	--	----	---------

NAN YA PLASTICS CORP. ELEC. MATERIALS DIV. LCD DEPARTMENT	SPECIFICATION	SPEC. NO. : LM489-5 DATE : Nov. 01, 2007 SHEET NO. : 9-4
---	---------------	--

\*Test and measurement are performed under the following conditions, unless otherwise specified.

Temperature       $20 \pm 15^{\circ}\text{C}$   
 Humidity           $65 \pm 20\%\text{R.H.}$   
 Pressure          860~1060hPa(mmbar)

In case of doubtful judgment, it is performed under the following conditions.

Temperature       $20 \pm 2^{\circ}\text{C}$   
 Humidity           $65 \pm 5\%\text{R.H.}$   
 Pressure          860~1060hPa(mmbar)

#### 5.Specification for quality check

##### 5-1 Electrical characteristics

NO.	Item	Criterion
1	Non operational	Fail
2	Miss operating	Fail
3	Missing dot	Fail
4	Contrast irregular	Fail
5	Response time	Within Specified value
6	Backlight turn on/off	Within Specified value

REV/DATE	R0/ 11.01.07'							BY	W.R.HSU
----------	------------------	--	--	--	--	--	--	----	---------

SPECIFICATION

5-2 External Appearance Defect

NO.	Item	Criterion																
1	Black spots, foreign matter, and white spots (Including light leakage due to pinholes of polarizing plates, etc.)	<p>(1)-1-Spots</p> <table border="1" data-bbox="810 600 1358 824"> <thead> <tr> <th>Average Diameter (mm):D</th> <th>Number of pieces permitted</th> </tr> </thead> <tbody> <tr> <td><math>D \leq 0.3</math></td> <td>Ignore</td> </tr> <tr> <td><math>0.3 &lt; D \leq 0.75</math></td> <td>5</td> </tr> <tr> <td><math>0.75 &lt; D</math></td> <td>0</td> </tr> </tbody> </table> <p>Number of total pieces is set to within 5 pieces.</p> <p>Note that when there are 2 pieces or more, they are not to be concentrated. Set as: Average diameter = (Long diameter + Short diameter)/2</p> <p>(1)-2-Blurred Spots(At lighting condition)</p> <table border="1" data-bbox="810 1265 1358 1489"> <thead> <tr> <th>Average Diameter (mm):D</th> <th>Number of pieces permitted</th> </tr> </thead> <tbody> <tr> <td><math>D \leq 0.3</math></td> <td>Ignore</td> </tr> <tr> <td><math>0.3 &lt; D \leq 0.75</math></td> <td>5</td> </tr> <tr> <td><math>0.75 &lt; D</math></td> <td>0</td> </tr> </tbody> </table> <p>Number of total pieces is set to within 5 pieces.</p> <p>Note that when there are 2 pieces or more, they are not to be concentrated. Set as: Average diameter = (Long diameter + Short diameter)/2</p>	Average Diameter (mm):D	Number of pieces permitted	$D \leq 0.3$	Ignore	$0.3 < D \leq 0.75$	5	$0.75 < D$	0	Average Diameter (mm):D	Number of pieces permitted	$D \leq 0.3$	Ignore	$0.3 < D \leq 0.75$	5	$0.75 < D$	0
Average Diameter (mm):D	Number of pieces permitted																	
$D \leq 0.3$	Ignore																	
$0.3 < D \leq 0.75$	5																	
$0.75 < D$	0																	
Average Diameter (mm):D	Number of pieces permitted																	
$D \leq 0.3$	Ignore																	
$0.3 < D \leq 0.75$	5																	
$0.75 < D$	0																	

SPECIFICATION

1	Line	<p>(1)-1-Lines</p> <table border="1" data-bbox="810 465 1353 734"> <thead> <tr> <th>Width(mm):W</th> <th>Length(mm): L</th> <th>Number of pieces permitted</th> </tr> </thead> <tbody> <tr> <td><math>W \leq 0.03</math></td> <td>Ignore</td> <td>Ignore</td> </tr> <tr> <td><math>0.03 &lt; W \leq 0.08</math></td> <td><math>L \leq 4</math></td> <td>2</td> </tr> <tr> <td><math>0.08 &lt; W \leq 0.1</math></td> <td><math>L \leq 1</math></td> <td>1</td> </tr> </tbody> </table> <p>Object exceeding 0.1mm follow the standards of the spots form. Note that when there are 2 pieces or more, they are not to be concentrated.</p> <p>(1)-2-Blurred Lines(At lighting condition)</p> <table border="1" data-bbox="810 999 1353 1267"> <thead> <tr> <th>Width(mm):W</th> <th>Length(mm): L</th> <th>Number of pieces permitted</th> </tr> </thead> <tbody> <tr> <td><math>W \leq 0.03</math></td> <td>Ignore</td> <td>Ignore</td> </tr> <tr> <td><math>0.03 &lt; W \leq 0.08</math></td> <td><math>L \leq 3</math></td> <td>6</td> </tr> <tr> <td><math>0.08 &lt; W</math></td> <td><math>3 &lt; L</math></td> <td>None</td> </tr> </tbody> </table> <p>Object exceeding 0.1mm follow the standards of the spots form. Note that when there are 2 pieces or more, they are not to be concentrated.</p>	Width(mm):W	Length(mm): L	Number of pieces permitted	$W \leq 0.03$	Ignore	Ignore	$0.03 < W \leq 0.08$	$L \leq 4$	2	$0.08 < W \leq 0.1$	$L \leq 1$	1	Width(mm):W	Length(mm): L	Number of pieces permitted	$W \leq 0.03$	Ignore	Ignore	$0.03 < W \leq 0.08$	$L \leq 3$	6	$0.08 < W$	$3 < L$	None
Width(mm):W	Length(mm): L	Number of pieces permitted																								
$W \leq 0.03$	Ignore	Ignore																								
$0.03 < W \leq 0.08$	$L \leq 4$	2																								
$0.08 < W \leq 0.1$	$L \leq 1$	1																								
Width(mm):W	Length(mm): L	Number of pieces permitted																								
$W \leq 0.03$	Ignore	Ignore																								
$0.03 < W \leq 0.08$	$L \leq 3$	6																								
$0.08 < W$	$3 < L$	None																								
2	Scratches(Glass, reflection plates, and polarizing plates)	In accordance with black spots. (At non lighting condition)																								
3	Color irregular	Not remarkable color irregular.																								

SPECIFICATION

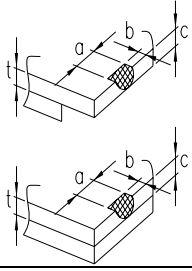
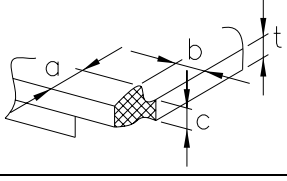
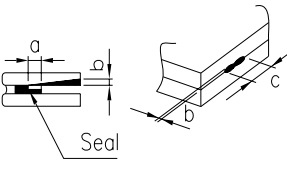
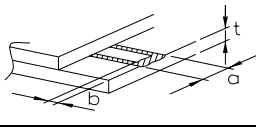
4	Air bubbles polarizing plates, and reflection plates	<table border="1" data-bbox="810 421 1193 645"> <thead> <tr> <th>Average Diameter (mm):D</th> <th>Number of pieces permitted</th> </tr> </thead> <tbody> <tr> <td><math>D \leq 0.3</math></td> <td>Ignore</td> </tr> <tr> <td><math>0.3 &lt; D</math></td> <td>0</td> </tr> </tbody> </table> <p data-bbox="1193 443 1369 627">Average diameter = (Long diameter + Short diameter)/2</p> <p data-bbox="813 658 1369 725">Note that when there are 4 pieces or more, they are not to be concentrated.</p>		Average Diameter (mm):D	Number of pieces permitted	$D \leq 0.3$	Ignore	$0.3 < D$	0
Average Diameter (mm):D	Number of pieces permitted								
$D \leq 0.3$	Ignore								
$0.3 < D$	0								
5	Cracks	<p>(1)General crack</p> 	<p><math>a \leq 5</math> <math>b \leq 2</math> <math>c \leq t</math></p> <p>Where, a and b are ignored when less than or equal to 0.5 . The numbers of pieces are set at up to 5 pieces.</p>						
		<p>(2)Corner crack</p> 	<p><math>a \leq 2.5</math> <math>b \leq 2.5</math> <math>c \leq t</math> <math>a+b \leq 4</math></p>						
		<p>(3)Seal portion crack</p> 	<p><math>a \leq \text{The seal width} \times 1/3</math> <math>b \leq t \times 2/3</math> <math>c \leq 5</math></p> <p>The numbers of pieces are set at up to 5 pieces.</p>						
		<p>(4)ITO Pin crack</p> 	<p><math>a \leq 5</math> <math>b \leq 1/3 \text{ pin length}</math> <math>c \leq t</math></p>						
		<p>(5)Progressive cracks</p>	<p>All taken to be unacceptable.</p>						

NAN YA PLASTICS CORP. ELEC. MATERIALS DIV. LCD DEPARTMENT	<b>SPECIFICATION</b>	SPEC. NO. : LM489-5 DATE : Nov. 01, 2007 SHEET NO. : 9-8
---	----------------------	--

6	Outer dimensions	Should be within the tolerance.
7	Newton ring(touch panel)	Orbicular of interference fringes is not allowed in the optimum contrast within the active area under viewing angle.
8	Soldering	Should be no defective soldering such as shorting, loose terminal cold solder, peeling of printed circuit board pattern, improper mounting position, etc.

5-3 Dot Appearance Defect

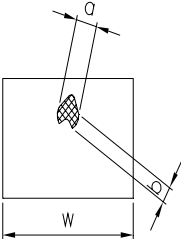
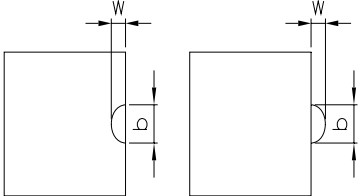
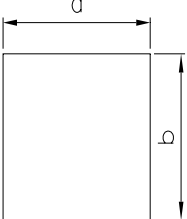
NO.	Item	Criteria	
1	Pinhole		Dot display a and b are each $\leq 0.2\text{mm}$ . The overall total is taken be with in 10 units. Note that they are not to be concentrated.
2	Missing		Dot display a and b are each $\leq 0.2\text{mm}$ . The overall total is taken to be with in 10 units.
3	Thick and thin display		Taken to be within $\pm 1.5\%$ of display character width(a) and height(b).

REV/DATE	R0/ 11.01.07'							BY	W.R.HSU
----------	------------------	--	--	--	--	--	--	----	---------

NAN YA PLASTICS CORP. ELEC. MATERIALS DIV. LCD DEPARTMENT	<b>SPECIFICATION</b>	SPEC. NO. : LM489-5 DATE : Nov. 01, 2007 SHEET NO. : 9-9
---	----------------------	--

NOTICE:

- SAFETY

1. If the LCD panel breaks, be careful not to get the liquid crystal to touch your skin.
2. If the liquid crystal touches your skin or clothes, please wash it off immediately by using soap and water.

- HANDLING

1. Avoid static electricity which can damage the CMOS LSI.
2. Do not remove the panel or frame from the module.
3. The polarizing plate of the display is very fragile. So, please handle it very carefully.
4. Do not wipe the polarizing plate with a dry cloth, as it may easily scratch the surface of plate.
5. Do not use ketonics solvent & Aromatic solvent. Use a soft cloth soaked with a cleaning naphtha solvent.

- STORAGE

1. Store the panel or module in a dark place where the temperature is  $25\pm 5^{\circ}\text{C}$  and the humidity is below 65% RH.
2. Do not place the module near organics solvents or corrosive gases.
3. Do not crush, shake, or jolt the module.

- TERMS OF WARRANT

1. Acceptance inspection period  
The period is within one month after the arrival of contracted commodity at the buyer's factory site.
2. Applicable warrant period  
The period is within twelve months since the date of shipping out under normal using and storage conditions.

REV/DATE	R0/ 11.01.07'								BY W.R.HSU
----------	------------------	--	--	--	--	--	--	--	---------------

10. OUTLINE DRAWING

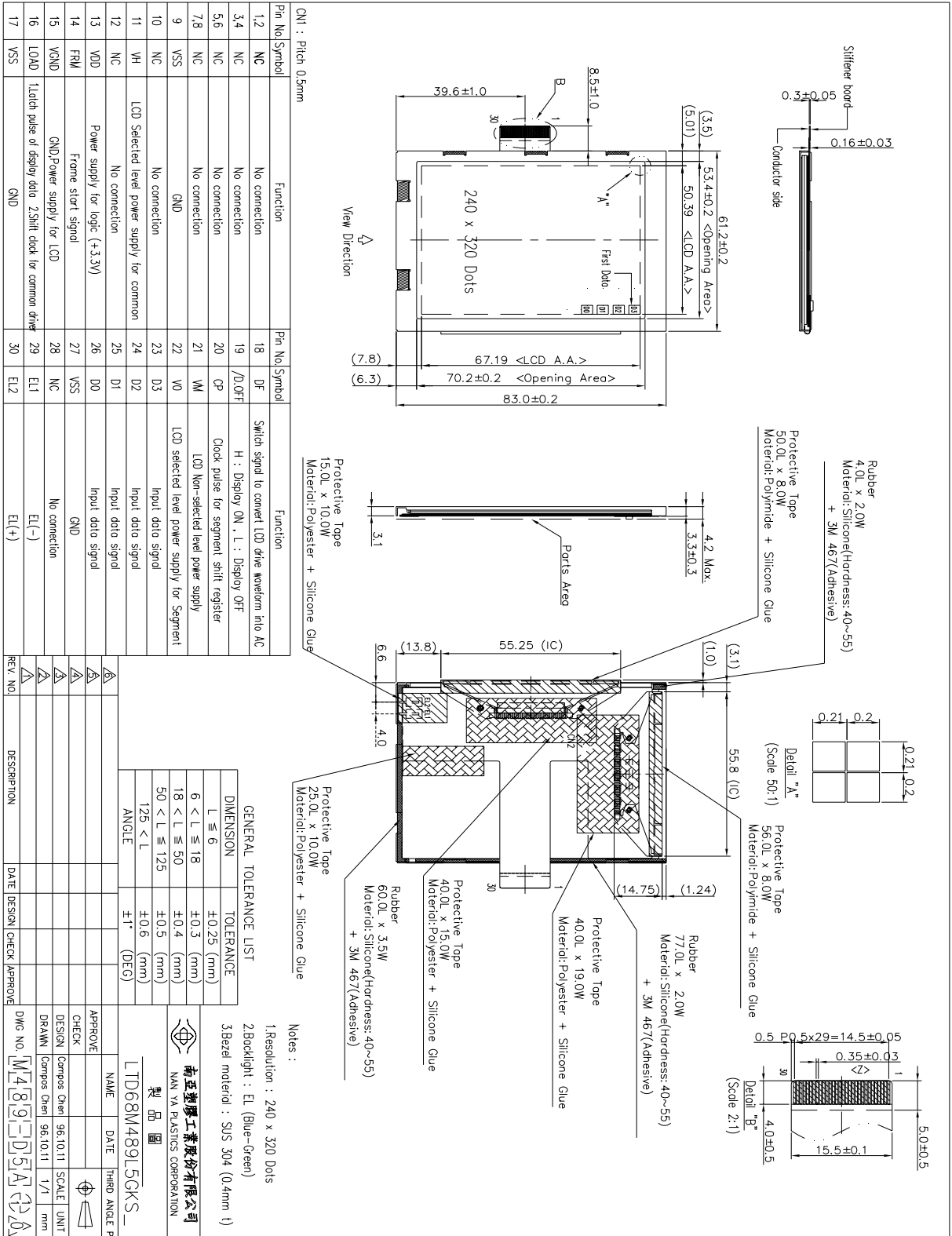

Pin No./Symbol	Function	Pin No./Symbol	Function
12 NC	No connection	18 DF	Switch signal to convert LCD drive waveform into AC
3,4 NC	No connection	19 /D/OFF	H : Display ON, L : Display OFF
5,6 NC	No connection	20 CP	Clock pulse for segment shift register
7,8 NC	No connection	21 VM	LCD Non-selected level power supply
9 VSS	GND	22 V0	LCD selected level power supply for Segment
10 NC	No connection	23 D3	Input data signal
11 VH	LCD Selected level power supply for common	24 D2	Input data signal
12 NC	No connection	25 D1	Input data signal
13 VDD	Power supply for logic (+3.3V)	26 D0	Input data signal
14 FRM	Frame start signal	27 VSS	GND
15 VAND	GND/Power supply for LCD	28 NC	No connection
16 LOAD	Latched pulse of display data 2.5bit clock for common driver	29 EL1	EL(-)
17 VSS	GND	30 EL2	EL(+)

REV. NO.	DESCRIPTION	DATE	DESIGN	CHECK	APPROVE