

NAN YA PLASTICS CORPORATION

SPECIFICATION OF
LCD MODULE
PRODUCT NO.: LMC97H436ADLS

SPEC. NO.: LM436-0K- \triangle

CUSTOMER
APPROVED BY
DATE:

LCD DEPARTMENT
ELECTRONIC MATERIALS DIVISION
NAN YA PLASTICS CORPORATION
201, TUNG HWA N. ROAD, TAIPEI
TEL: 886-2-27122211 EXT. 5993~5995
FAX: 886-2-27178253
E-mail: lcdsales@npc.com.tw

EDITED ON : AUGUST.07.2006

Q.C. DEPT.	DESIGN MANAGER	DESIGN CHECK	DESIGNER
			C.Y.CHAN

1. MECHANICAL DATA

NO	ITEM	CONTENTS	UNIT
1	Product No.	LMC97H436ADLS	-
2	Module Size	93.0 (W) x 70.0 (H) x MAX.14.0 (D)	mm
3	Dot Size	0.48 (W) x 0.48 (H)	mm
4	Dot Pitch	0.52 (W) x 0.52 (H)	mm
5	Number of Dots	128 (W) x 64 (H)	Dot
6	Duty	1/64	-
7	LCD Display Mode	Gray Mode	-
8	Rear Polarizer	Transflective(High Transparency)	-
9	Viewing Direction	6	O'clock
10	Backlight	LED	-
11	Controller	NT7107 / NT7108 OR COMPATIBLE	-
12	DC/DC Converter	Included	-
13	Touch Panel	Excluded	-
14	Weight	75.0 (Approx.)	g

Note :

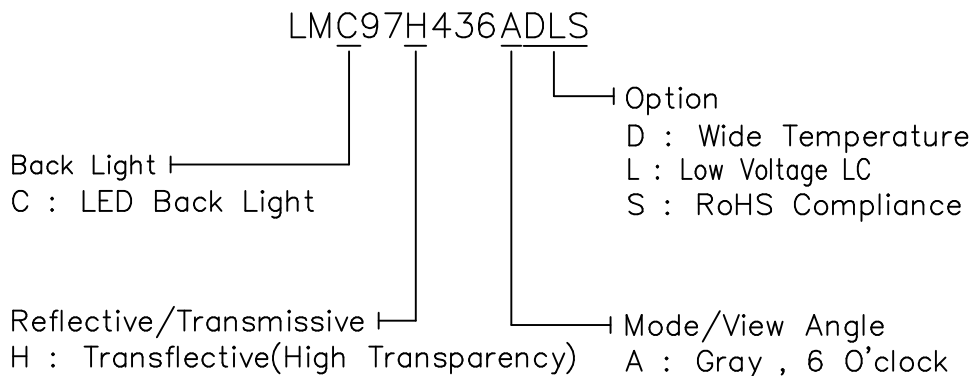

RoHS Compliance.

Nan Ya guarantees that this project doesn't include any materials (6 materials) or includes less than specified quantities which are regulated by RoHS Compliance.

2. ABSOLUTE MAXIMUM RATINGS

(1) ELECTRICAL ABSOLUTE RATINGS

V_{SS}=0V

	SYMBOL	MIN	MAX	UNIT	COMMENT
Power Supply for Logic	VDD-VSS	-0.3	7.0	V	
Input Voltage	V _I	-0.3	VDD	V	
Static Electricity	-	-	-		Note 1

Note 1 LCM should be grounded during handling LCM.

(2) ENVIRONMENTAL ABSOLUTE MAXIMUM RATINGS

ITEM	WIDE TEMP.			
	OPERATING		STORAGE	
	MIN.	MAX.	MIN.	MAX.
Ambient Temperature	-20	70	-40	80
Humidity (Without Condensation)	Note 2,4		Note 3,4	

Note 2 Ta ≤ 70°C : 75%RH max

Note 3 Please refer to item of reliability test

Note 4 Background color will change slightly depending on ambient temperature.

That phenomenon is reversible.

3. ELECTRICAL CHARACTERISTICS

3-1. ELECTRICAL CHARACTERISTICS OF LCM

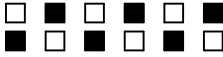
ITEM	SYMBOL	CONDITION	MIN.	TYP.	MAX.	UNIT	
Power Supply for Logic	VDD-VSS	-	4.5	5.0	5.5	V	
Input Voltage	VIH	H level	0.8VDD	-	VDD	V	
	VIL	L level	0	-	0.2VDD		
Recommended LC Driving Voltage	VDD-VO	Duty = 1/64	-20°C	9.3	9.7	10.0	V
			0°C	8.7	9.1	9.5	
			25°C	8.4	8.8	9.2	
			50°C	8.3	8.7	9.1	
			70°C	8.0	8.4	8.8	
Power Supply Current	IDD	VDD = 5.0V VDD-VO=8.8 V Ta=25°C Pattern: 	-	2	3	mA	
Surface Luminance of LCM	L	(I _{AK} = 250mA) Pattern: Dots All ON	-	7	-	cd/m ²	
		(I _{AK} = 250mA) Pattern: Dots All OFF	10	15	-		

3-2.ELECTRICAL CHARACTERISTICS OF BACKLIGHT

Used LED Rating (Constant Current Driving)

Temp.=25°C

ITEM	SYMBOL	MIN.	TYP.	MAX.	UNIT	REMARK
Peak forward current	I_P	-	-	540	mA	-
Maximum reverse voltage	V_R	-	-	8	V	-
Applied forward current	I_{AK}	-	250	-	mA	-
Applied forward voltage	V_{AK}	-	4.2	4.6	V	-
LED power consumption	P_F	-	1.05	1.15	W	-
LED life time	L_L	-	40000	-	hrs	at $I_{AK} = 250 \text{ mA}$ (*1)

(*1) LED life time is defined as follows : The final brightness is at 50% of original brightness.

4. OPTICAL CHARACTERISTICS

AT V_{op}

ITEM		Cr(Contrast Ratio)										θ (Viewing Angle)		ϕ (Viewing Angle)	
		-20°C		0°C		25°C		50°C		70°C		25°C		25°C	
MODE		MIN.	TYP.	MIN.	TYP.	MIN.	TYP.	MIN.	TYP.	MIN.	TYP.	MIN.	TYP.	MIN.	TYP.
H	A	2.0	3.0	2.0	3.5	2.5	4.0	2.0	3.5	2.0	2.8	-	(F)25 (R)20	-	(L)20 (R)20
Note		NOTE 6										NOTE 5			

Note:

H: Transflective(High Transparency)

A: Gray , 6 O'clock

AT $\phi=0^\circ$ $\theta=0^\circ$

ITEM	SYMBOL	CONDITION	MIN.	TYP.	MAX.	UNIT	NOTE
Response Time (rise)	Tr	-20°C	2800	3500	5200	ms	Fig. 2
		0°C	680	850	1270		
		25°C	160	200	300		
		50°C	95	120	180		
		70°C	45	60	90		
Response Time (fall)	Tf	-20°C	1900	2400	3600	ms	Fig. 2
		0°C	400	500	600		
		25°C	95	120	180		
		50°C	40	50	75		
		70°C	30	40	60		

(NOTE 1)

Definition of Operation Voltage(Vop)

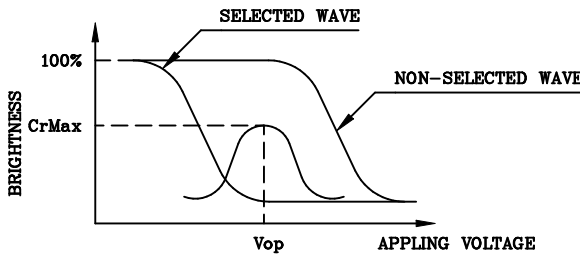

(positive type)

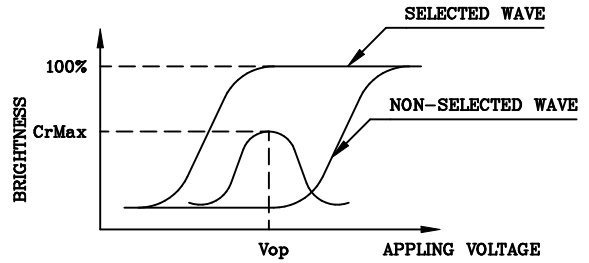

(negative type)

*Conditions

Viewing Angle : 0
Frame Frequency : 70Hz
Applying Waveform : 1/N duty 1/a bias

(NOTE 2)

Definition of Response Time(Tr,Tf)

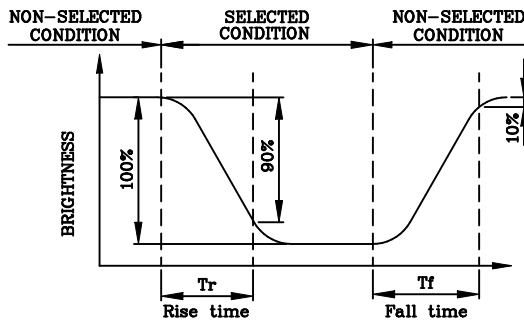

(positive type)

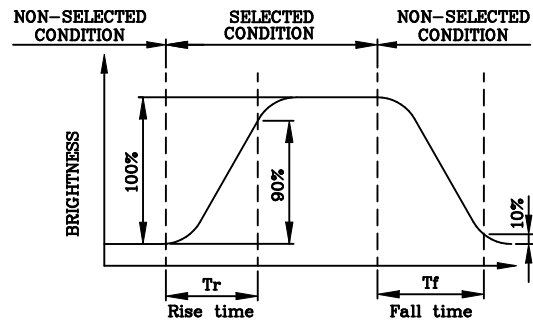

(negative type)

*Conditions

Operating Voltage : Vop
Viewing Angle (θ, ϕ) : (0,0)
Frame Frequency : 70Hz
Applying Waveform : 1/N duty 1/a bias

(NOTE 3)

Description of Measuring Equipment and Driving Waveforms

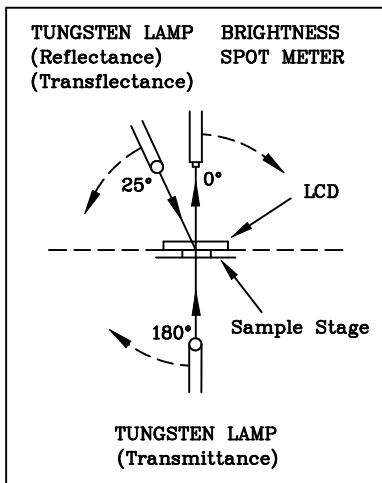

CONST.
TEMP.
CHAMBER

Multiplex Driving (1/N duty 1/a bias)

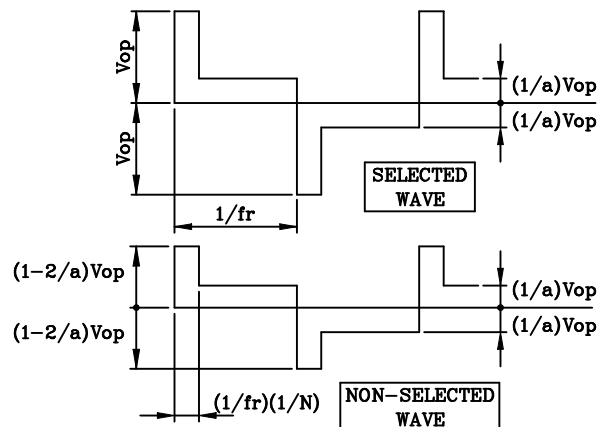

(NOTE 4)

Definition of Viewing Direction

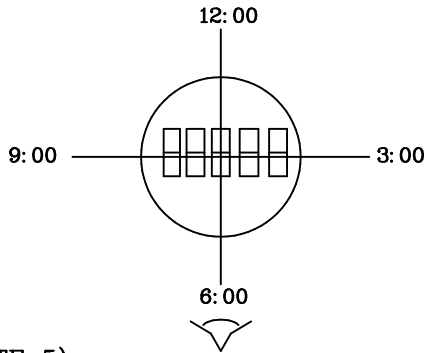

(NOTE 5)

Definition of Viewing Angle

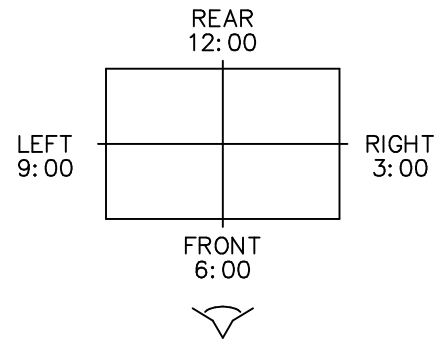
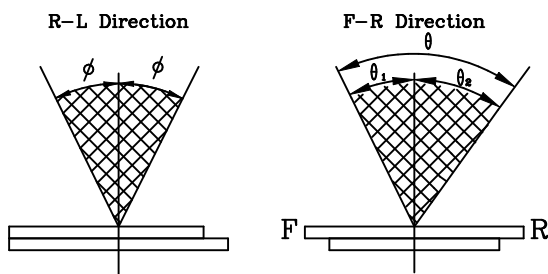

$$\theta = \theta_1 + \theta_2$$

*Conditions

Operating Voltage : V_{op}
 Frame Frequency : 70Hz
 Applying Waveform : 1/N duty 1/a bias
 Contrast Ratio : larger than 2

(NOTE 6)

Definition of Contrast Ratio (Cr)

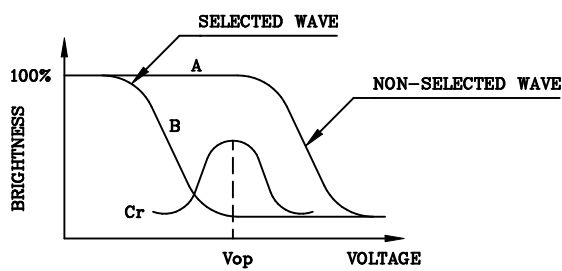

(positive type)

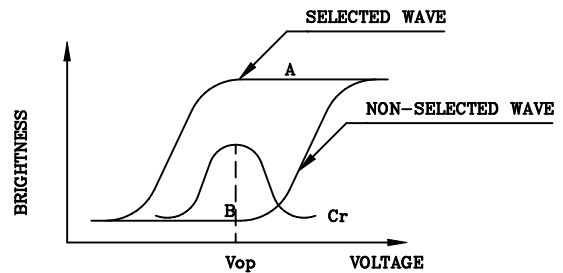

(negative type)

Contrast Ratio : $Cr = A/B$

*Conditions

Viewing Angle : 0
 Frame Frequency : 70Hz
 Applying Waveform : 1/N duty 1/a bias

5. BLOCK DIAGRAM

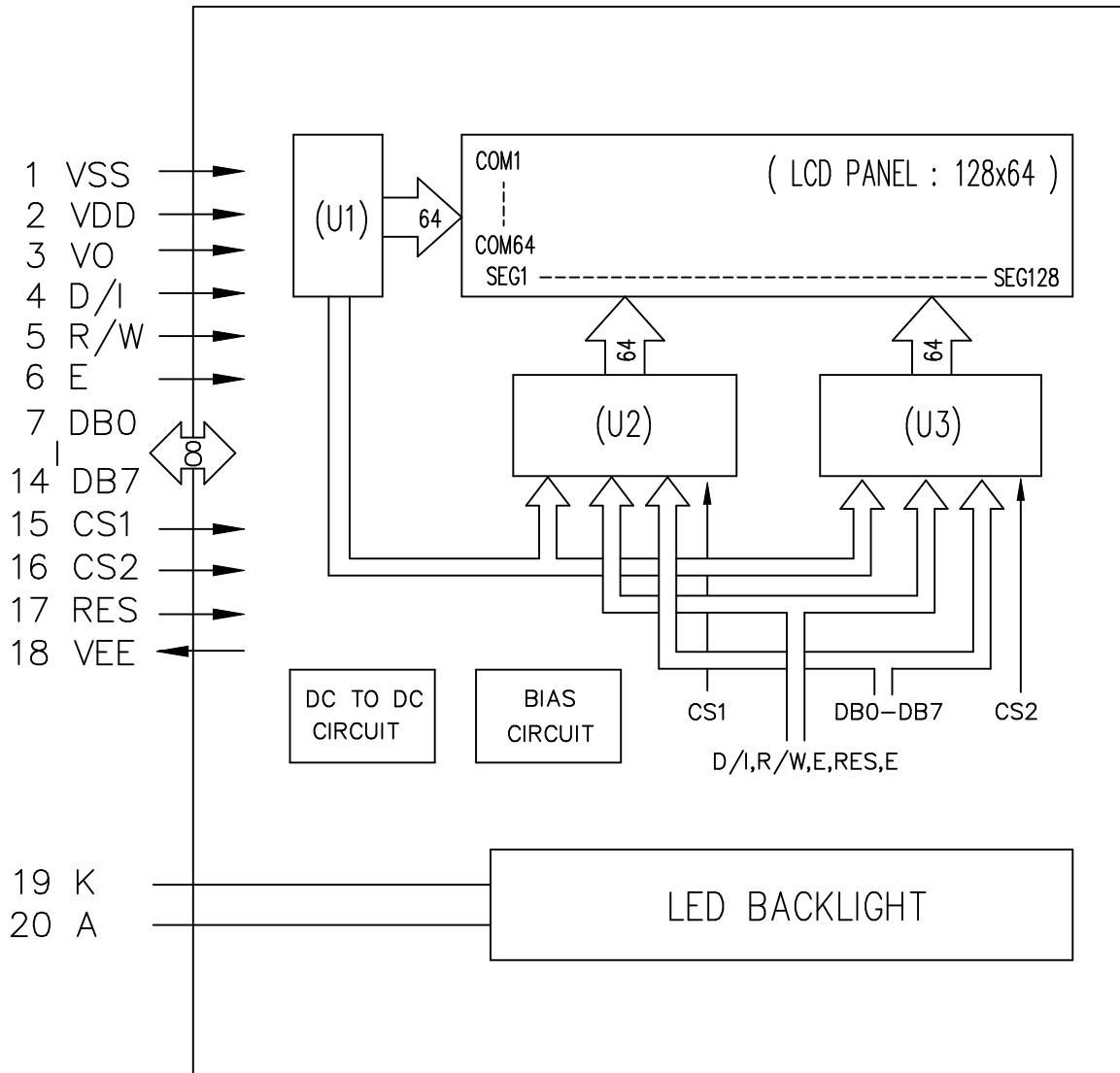

6. DEFINITION OF INTERFACE

Pin No.	Symbol	Level	Function
1	VSS	-	0V Power Supply
2	VDD	-	
3	V0	-	Operating Voltage for LCD Driving
4	D/I	H/L	H : Data Input L : Instruction Code Input
5	R/W	H/L	H : Data Read (LCM to MPU) L : Data Write (MPU to LCM)
6	E	H,H→L	Enable Signal
7	DB0	H/L	Data Bus Line
8	DB1		
9	DB2		
10	DB3	H/L	Data Bus Line
11	DB4		
12	DB5		
13	DB6		
14	DB7		
15	CS1	H	Chip Select for IC1
16	CS2	H	Chip Select for IC2
17	RES	L	Reset Active "L"
18	VEE	-	Negative Voltage Output
19	K	-	Cathode for EL/LED Backlight
20	A	-	Anode for EL/LED Backlight

7. POWER SUPPLY

LCM

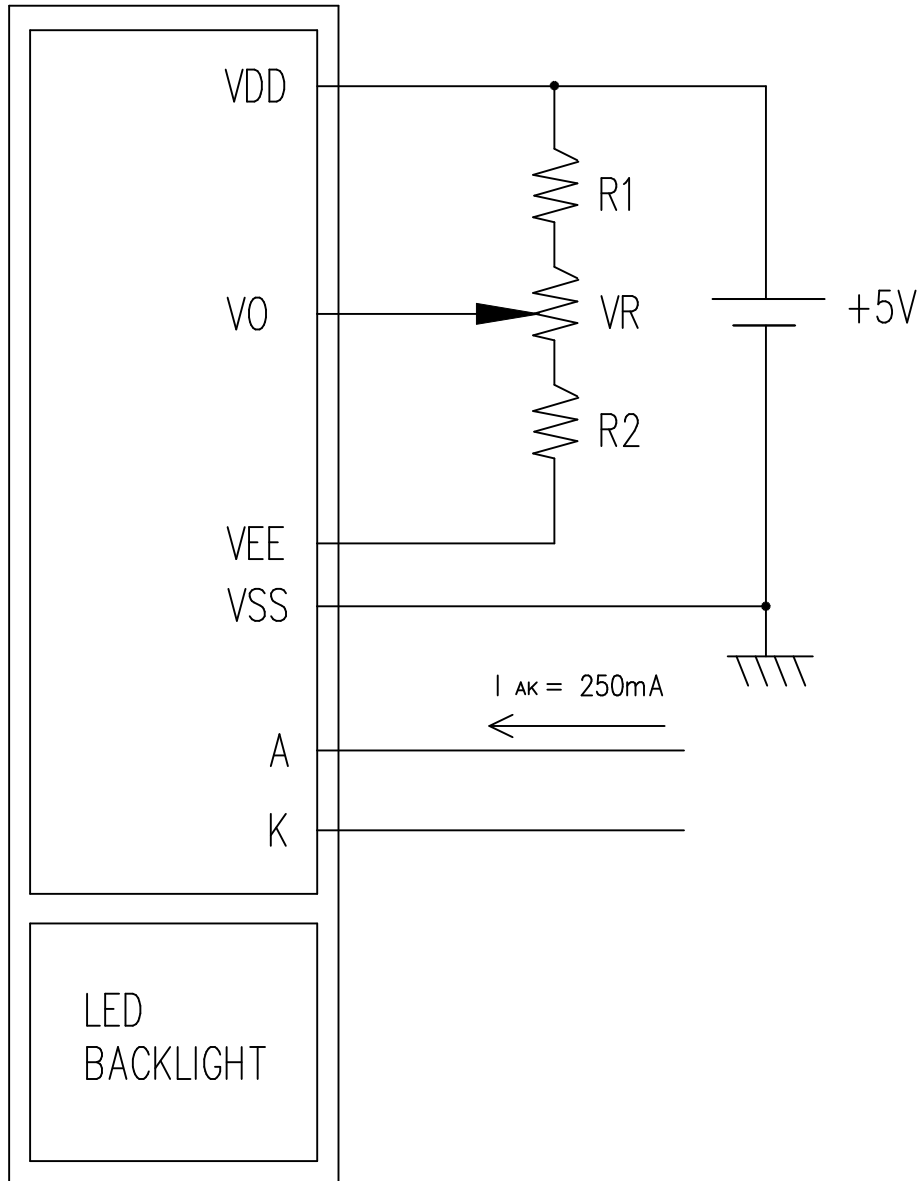

Note:

$$R1 + VR + R2 \approx 20\text{K}\Omega$$

8-1.INTERFACE TIMING CHARACTERISTICS

Item	Symbol	Test condition	Min.	Typ.	Max.	Unit
Enable cycle time	t _{cyc}	Fig.a , Fig.b	1000	-	-	ns
E high level width	PWEH	Fig.a , Fig.b	450	-	-	ns
E low level width	PWEL	Fig.a , Fig.b	450	-	-	ns
E rise/fall time	t _r , t _f	Fig.a , Fig.b	-	-	25	ns
Address set up time	t _{AS}	Fig.a , Fig.b	140	-	-	ns
Address hold time	t _{AH}	Fig.a , Fig.b	10	-	-	ns
Data delay time	t _{DDR}	Fig.b	-	-	320	ns
Data set up time	t _{DSW}	Fig.a	200	-	-	ns
Data hold time (WR)	t _{DHW}	Fig.a	10	-	-	ns
Data hold time (RD)	t _{DHR}	Fig.b	20	-	-	ns

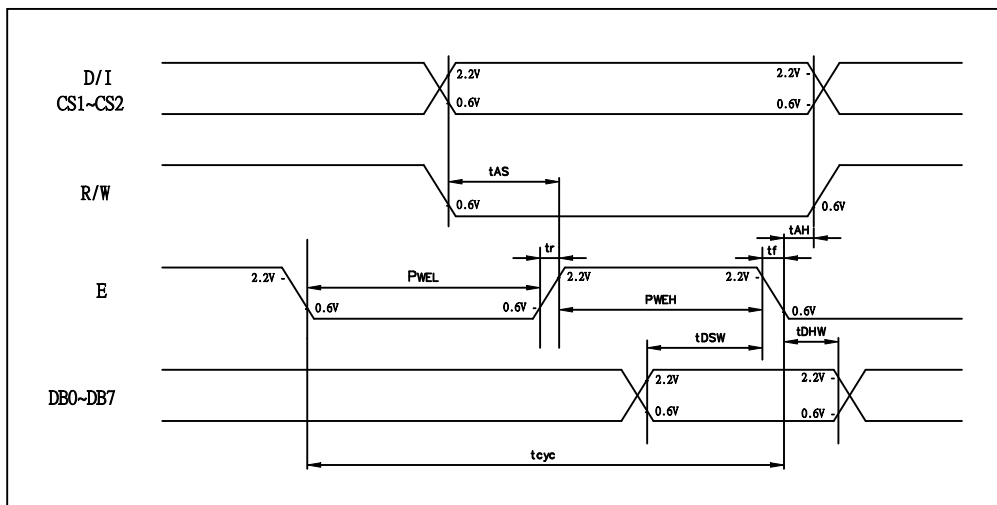

Fig.(a) Interface timing (data write)

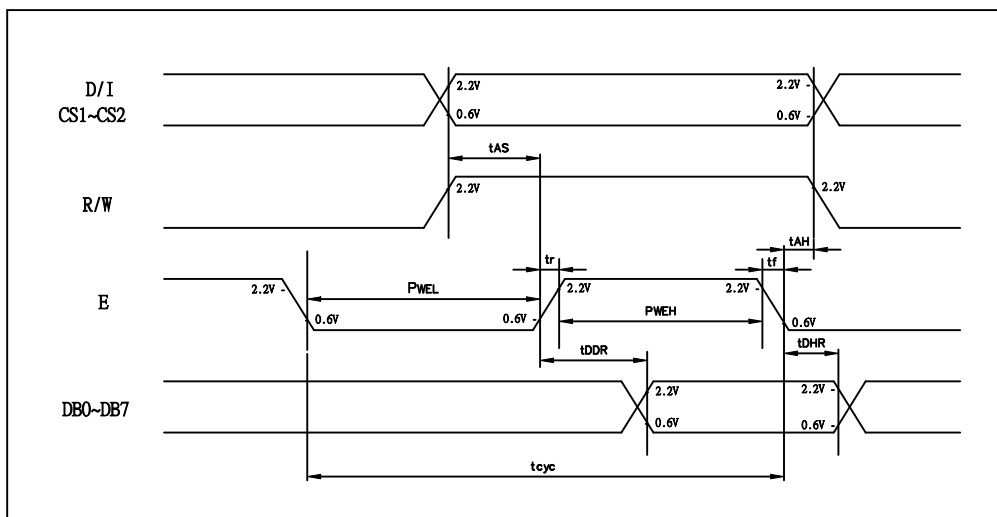
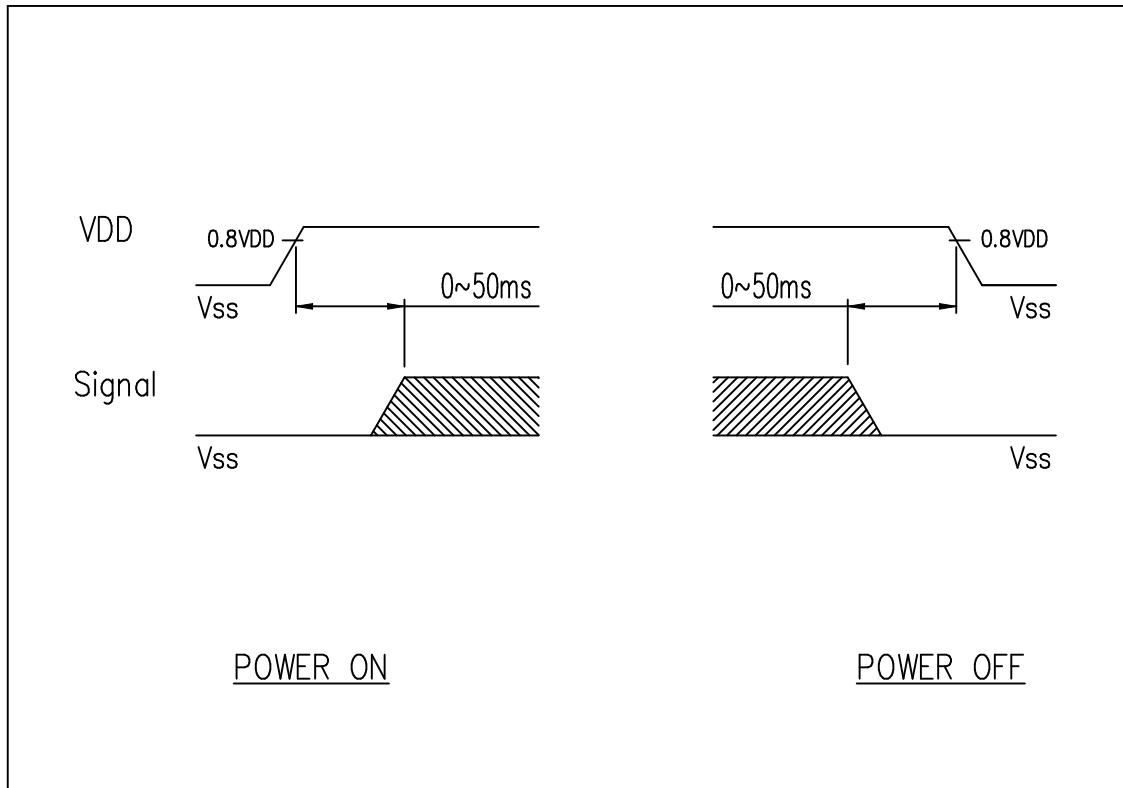

Fig.(b) Interface timing (data read)

8-2. POWER ON/OFF TIMING CHARACTERISTICS



** The missing pixels may occur when the LCM is driven beyond above power interface timing sequence.

8-3.DISPLAY PATTERN

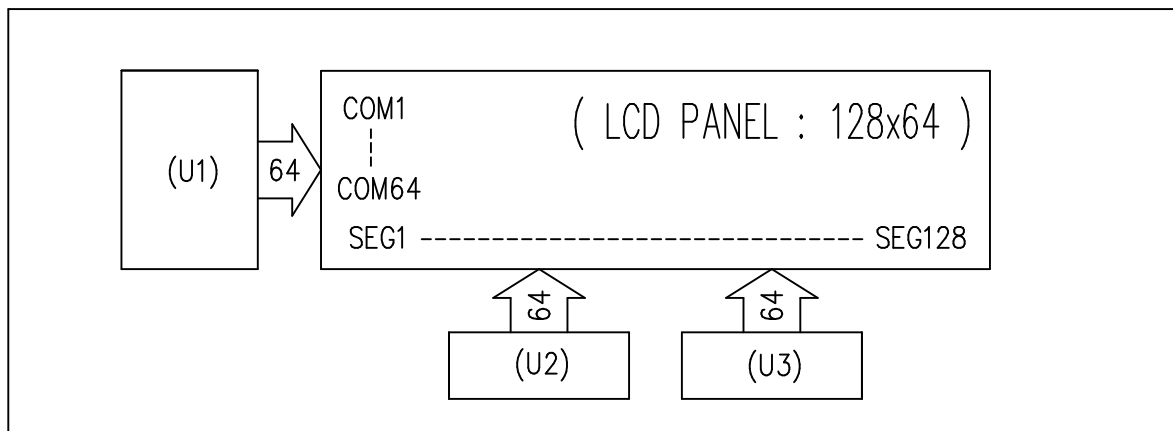
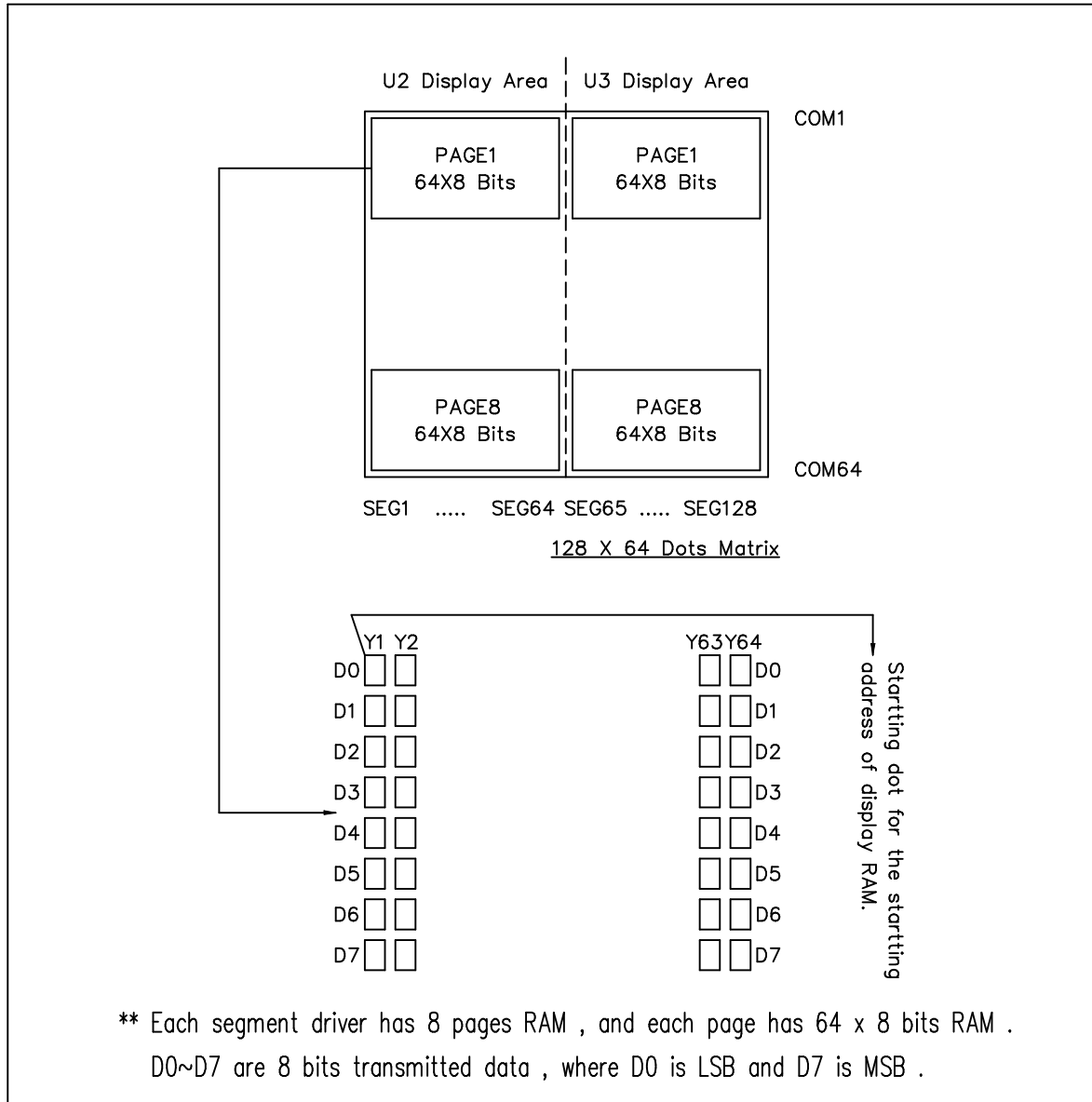

9. RELIABILITY TEST

WIDE TEMPERATURE RELIABILITY TEST

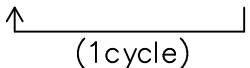
NO	ITEM	CONDITION			STANDARD	NOTE
1	High Temp. Storage	80°C	120Hrs		Appearance without defect	
2	Low Temp. Storage	-40°C	120Hrs		Appearance without defect	
3	High Temp. & High Humi. Storage	60°C 90%RH	120Hrs		Appearance without defect	
4	High Temp. Operating Display	70°C	120Hrs		Appearance without defect	
5	Low Temp. Operating Display	-20°C	120Hrs		Appearance without defect	
6	Thermal Shock	$-20^{\circ}\text{C}, 30\text{min} \rightarrow 70^{\circ}\text{C}, 30\text{min}$  (1cycle)			Appearance without defect	10 cycles

Inspection Provision

1. Purpose

The NAN YA inspection provision provides outgoing inspection provision and its expected quality level based on our outgoing inspection of NAN YA LCD produces.

2. Applicable Scope

The NAN YA inspection provision is applicable to the arrangement in regard to outgoing inspection and quality assurance after outgoing.

3. Technical Terms

3-1 NAN YA Technical Terms

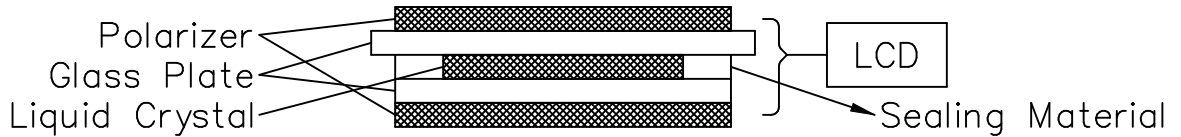

4. Outgoing Inspection

4-1 Inspection Method

MIL-STD-105E Level II Regular inspection

4-2 Inspection Standard

	Item		AQL(%)	Remarks
Major Defect	Dots	Opens Shorts Erroneous operation	0.4	faults which substantially lower the practicality and the initial purpose difficult to achieve.
	Solder appearance	Shorts Loose		
	Cracks	Display surface cracks		

	Dimensions	External from Dimensions	0.4	
Minor Defect	Inside the glass	Black spots	0.65	faults which appear to pose almost no obstacle to the practicality, effective use, and operation.
	Polarizing plate	Scratches, foreign Matter, air bubbles, and peeling		
	Dots	Pinhole, deformation		
	Color tone	Color unevenness		
	Solder appearance	Cold solder Solder projections		

4-3 Inspection Provisions
*Viewing Area Definition

Fig. 1

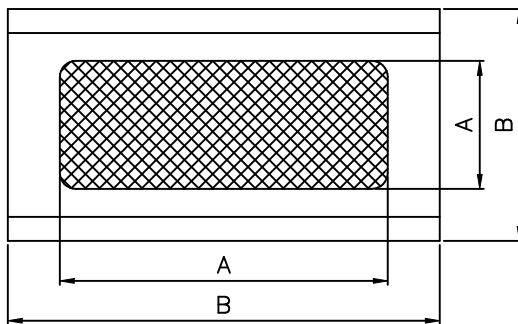

A : Zone Viewing Area
B : Zone Glass Plate Outline

*Inspection place to be 500 to 1000 lux illuminance uniformly without glaring.
The distance between luminous source(daylight fluorescent lamp and cool white fluorescent lamp) and sample to be 30cm to 50cm.

*Test and measurement are performed under the following conditions, unless otherwise specified.

Temperature 20± 15°C
Humidity 65± 20%R.H.
Pressure 860~1060hPa(mmbar)

In case of doubtful judgment, it is performed under the following conditions.

Temperature 20± 2°C
Humidity 65± 5%R.H.
Pressure 860~1060hPa(mmbar)

5.Specification for quality check
5-1 Electrical characteristics

NO.	Item	Criterion
1	Non operational	Fail
2	Miss operating	Fail
3	Missing dot	Fail
4	Contrast irregular	Fail
5	Response time	Within Specified value
6	Backlight turn on/off	Within Specified value

5-2 External Appearance Defect

NO.	Item	Criterion																		
1	Black spots, foreign matter, and white spots (Including light leakage due to pinholes of polarizing plates, etc.)	<p>(1)-1-Spots</p> <table border="1" data-bbox="711 477 1356 763"> <thead> <tr> <th>Average Diameter(mm):D</th> <th>Number of pieces permitted</th> </tr> </thead> <tbody> <tr> <td>$D \leq 0.1$</td> <td>Ignore</td> </tr> <tr> <td>$0.1 < D \leq 0.2$</td> <td>5</td> </tr> <tr> <td>$0.2 < D \leq 0.3$</td> <td>2</td> </tr> <tr> <td>$0.3 < D$</td> <td>0</td> </tr> </tbody> </table> <p>Number of total pieces is set to within 5 pieces.</p> <p>Note that when there are 2 pieces or more, they are not to be concentrated. Set as: Average diameter = (Long diameter + Short diameter)/2</p> <p>(1)-2-Blurred Spots(At lighting condition)</p> <table border="1" data-bbox="711 1187 1356 1426"> <thead> <tr> <th>Average Diameter(mm):D</th> <th>Number of pieces permitted</th> </tr> </thead> <tbody> <tr> <td>$D \leq 0.3$</td> <td>Ignore</td> </tr> <tr> <td>$0.3 < D \leq 0.75$</td> <td>5</td> </tr> <tr> <td>$0.75 < D$</td> <td>0</td> </tr> </tbody> </table> <p>Number of total pieces is set to within 5 pieces.</p> <p>Note that when there are 2 pieces or more, they are not to be concentrated. Set as: Average diameter = (Long diameter + Short diameter)/2</p>	Average Diameter(mm):D	Number of pieces permitted	$D \leq 0.1$	Ignore	$0.1 < D \leq 0.2$	5	$0.2 < D \leq 0.3$	2	$0.3 < D$	0	Average Diameter(mm):D	Number of pieces permitted	$D \leq 0.3$	Ignore	$0.3 < D \leq 0.75$	5	$0.75 < D$	0
Average Diameter(mm):D	Number of pieces permitted																			
$D \leq 0.1$	Ignore																			
$0.1 < D \leq 0.2$	5																			
$0.2 < D \leq 0.3$	2																			
$0.3 < D$	0																			
Average Diameter(mm):D	Number of pieces permitted																			
$D \leq 0.3$	Ignore																			
$0.3 < D \leq 0.75$	5																			
$0.75 < D$	0																			

SPECIFICATION

1	Line	<p>(1)-1-Lines</p> <table border="1" data-bbox="711 427 1453 712"> <thead> <tr> <th>Width(mm): W</th> <th>Length(mm): L</th> <th>Number of pieces permitted</th> </tr> </thead> <tbody> <tr> <td>$W \leq 0.03$</td> <td>Ignore</td> <td>Ignore</td> </tr> <tr> <td>$0.03 < W \leq 0.08$</td> <td>$L \leq 4$</td> <td>2</td> </tr> <tr> <td>$0.08 < W \leq 0.1$</td> <td>$L \leq 1$</td> <td>1</td> </tr> </tbody> </table> <p>Object exceeding 0.1mm follow the standards of the spots form. Note that when there are 2 pieces or more, they are not to be concentrated.</p> <p>(1)-2-Blurred Lines(At lighting condition)</p> <table border="1" data-bbox="711 1019 1453 1303"> <thead> <tr> <th>Width(mm): W</th> <th>Length(mm): L</th> <th>Number of pieces permitted</th> </tr> </thead> <tbody> <tr> <td>$W \leq 0.03$</td> <td>Ignore</td> <td>Ignore</td> </tr> <tr> <td>$0.03 < W \leq 0.08$</td> <td>$L \leq 3$</td> <td>6</td> </tr> <tr> <td>$0.08 < W$</td> <td>$3 < L$</td> <td>None</td> </tr> </tbody> </table> <p>Object exceeding 0.1mm follow the standards of the spots form. Note that when there are 2 pieces or more, they are not to be concentrated.</p>	Width(mm): W	Length(mm): L	Number of pieces permitted	$W \leq 0.03$	Ignore	Ignore	$0.03 < W \leq 0.08$	$L \leq 4$	2	$0.08 < W \leq 0.1$	$L \leq 1$	1	Width(mm): W	Length(mm): L	Number of pieces permitted	$W \leq 0.03$	Ignore	Ignore	$0.03 < W \leq 0.08$	$L \leq 3$	6	$0.08 < W$	$3 < L$	None
Width(mm): W	Length(mm): L	Number of pieces permitted																								
$W \leq 0.03$	Ignore	Ignore																								
$0.03 < W \leq 0.08$	$L \leq 4$	2																								
$0.08 < W \leq 0.1$	$L \leq 1$	1																								
Width(mm): W	Length(mm): L	Number of pieces permitted																								
$W \leq 0.03$	Ignore	Ignore																								
$0.03 < W \leq 0.08$	$L \leq 3$	6																								
$0.08 < W$	$3 < L$	None																								
2	Scratches(Glass, reflection plates, and polarizing plates)	In accordance with black spots. (At non lighting condition)																								
3	Color irregular	Not remarkable color irregular.																								

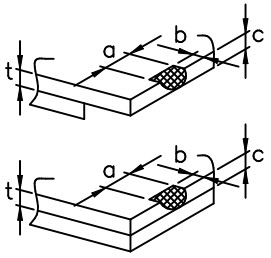
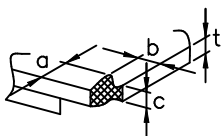
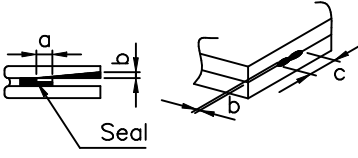
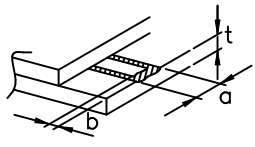
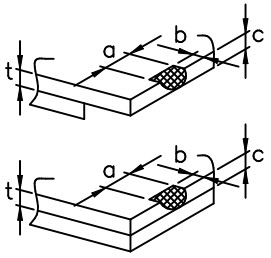
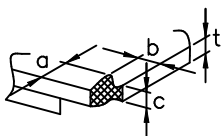
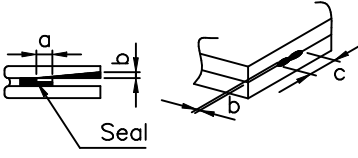
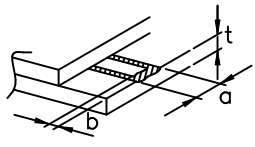
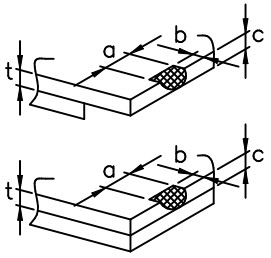
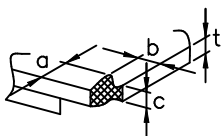
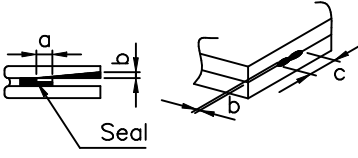
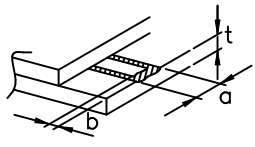
<p>4 Air bubbles polarizing plates, and reflection plates</p>	<table border="1" data-bbox="710 380 1225 672"> <tr> <th data-bbox="710 380 970 526">Average Diameter (mm):D</th> <th data-bbox="970 380 1225 526">Number of pieces permitted</th> <th data-bbox="1225 380 1476 672" rowspan="2">Average diameter = (Long diameter + Short diameter)/2</th> </tr> <tr> <td data-bbox="710 526 970 672">D ≤ 0.3 0.3 < D</td> <td data-bbox="970 526 1225 672">Ignore 0</td> </tr> </table> <p data-bbox="710 683 1476 779">Note that when there are 4 pieces or more, they are not to be concentrated.</p>		Average Diameter (mm):D	Number of pieces permitted	Average diameter = (Long diameter + Short diameter)/2	D ≤ 0.3 0.3 < D	Ignore 0					
Average Diameter (mm):D	Number of pieces permitted	Average diameter = (Long diameter + Short diameter)/2										
D ≤ 0.3 0.3 < D	Ignore 0											
<p>5 Cracks</p>	<table border="1" data-bbox="662 779 1476 1964"> <tr> <td data-bbox="662 779 1066 1171"> <p>(1)General crack</p>  </td> <td data-bbox="1066 779 1476 1171"> <p>a ≤ 5 b ≤ 2 c ≤ t</p> <p>Where, a and b are ignored when less than or equal to 0.5. The numbers of pieces are set at up to 5 pieces.</p> </td> </tr> <tr> <td data-bbox="662 1171 1066 1361"> <p>(2)Corner crack</p>  </td> <td data-bbox="1066 1171 1476 1361"> <p>a ≤ 2.5 b ≤ 2.5 c ≤ t a + b ≤ 4</p> </td> </tr> <tr> <td data-bbox="662 1361 1066 1635"> <p>(3)Seal portion crack</p>  </td> <td data-bbox="1066 1361 1476 1635"> <p>a ≤ The seal width × 1/3 b ≤ t × 2/3 c ≤ 5</p> <p>The numbers of pieces are set at up to 5 pieces.</p> </td> </tr> <tr> <td data-bbox="662 1635 1066 1870"> <p>(4)ITO Pin crack</p>  </td> <td data-bbox="1066 1635 1476 1870"> <p>a ≤ 5 b ≤ 1/3 pin length c ≤ t</p> </td> </tr> <tr> <td data-bbox="662 1870 1066 1964"> <p>(5)Progressive cracks</p> </td> <td data-bbox="1066 1870 1476 1964"> <p>All taken to be unacceptable.</p> </td> </tr> </table>		<p>(1)General crack</p> 	<p>a ≤ 5 b ≤ 2 c ≤ t</p> <p>Where, a and b are ignored when less than or equal to 0.5. The numbers of pieces are set at up to 5 pieces.</p>	<p>(2)Corner crack</p> 	<p>a ≤ 2.5 b ≤ 2.5 c ≤ t a + b ≤ 4</p>	<p>(3)Seal portion crack</p> 	<p>a ≤ The seal width × 1/3 b ≤ t × 2/3 c ≤ 5</p> <p>The numbers of pieces are set at up to 5 pieces.</p>	<p>(4)ITO Pin crack</p> 	<p>a ≤ 5 b ≤ 1/3 pin length c ≤ t</p>	<p>(5)Progressive cracks</p>	<p>All taken to be unacceptable.</p>
<p>(1)General crack</p> 	<p>a ≤ 5 b ≤ 2 c ≤ t</p> <p>Where, a and b are ignored when less than or equal to 0.5. The numbers of pieces are set at up to 5 pieces.</p>											
<p>(2)Corner crack</p> 	<p>a ≤ 2.5 b ≤ 2.5 c ≤ t a + b ≤ 4</p>											
<p>(3)Seal portion crack</p> 	<p>a ≤ The seal width × 1/3 b ≤ t × 2/3 c ≤ 5</p> <p>The numbers of pieces are set at up to 5 pieces.</p>											
<p>(4)ITO Pin crack</p> 	<p>a ≤ 5 b ≤ 1/3 pin length c ≤ t</p>											
<p>(5)Progressive cracks</p>	<p>All taken to be unacceptable.</p>											

6	Outer dimensions	Should be within the tolerance.
7	Newton ring(touch panel)	Orbicular of interference fringes is not allowed in the optimum contrast within the active area under viewing angle.
8	Soldering	Should be no defective soldering such as shorting, loose terminal cold solder, peeling of printed circuit board pattern, improper mounting position, etc.

5-3 Dot Appearance Defect

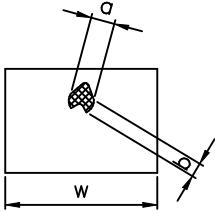
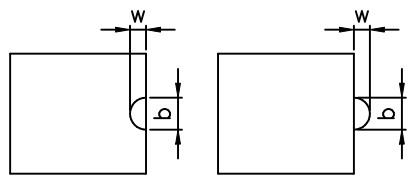
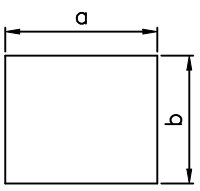
NO.	Item	Criteria
1	Pinhole	 <p>Dot display a and b are each $\leq 0.2\text{mm}$ The overall total is taken be with in 10 units. Note that they are not to be concentrated.</p>
2	Missing	 <p>Dot display a and b are each $\leq 0.2\text{mm}$ The overall total is taken to be with in 10 units.</p>
3	Thick and thin display	 <p>Taken to be within $\pm 1.5\%$ of display character width(a) and height(b).</p>

NOTICE:

- SAFETY

- 1.If the LCD panel breaks, be careful not to get the liquid crystal to touch your skin.
- 2.If the liquid crystal touches your skin or clothes, please wash it off immediately by using soap and water.

- HANDLING

- 1.Avoid static electricity which can damage the CMOS LSI.
- 2.Do not remove the panel or frame from the module.
- 3.The polarizing plate of the display is very fragile. So, please handle it very carefully.
- 4.Do not wipe the polarizing plate with a dry cloth, as it may easily scratch the surface of plate.
- 5.Do not use ketonics solvent & Aromatic solvent. Use a soft cloth soaked with a cleaning naphtha solvent.

- STORAGE

- 1.Store the panel or module in a dark place where the temperature is $25^{\circ}\text{C}\pm 5^{\circ}\text{C}$ and the humidity is below 65% RH.
- 2.Do not place the module near organics solvents or corrosive gases.
- 3.Do not crush, shake, or jolt the module.

- TERMS OF WARRANT

- 1.Acceptance inspection period
The period is within one month after the arrival of contracted commodity at the buyer's factory site.
- 2.Applicable warrant period
The period is within twelve months since the date of shipping out under normal using and storage conditions.

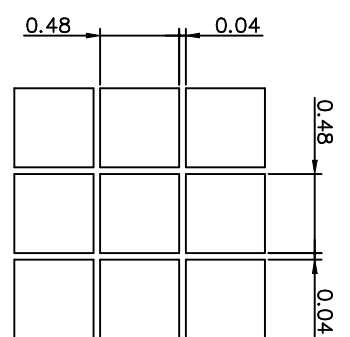
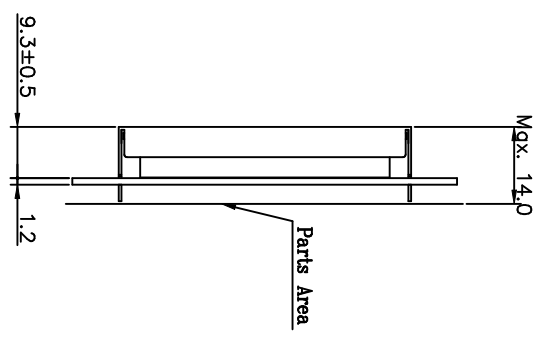
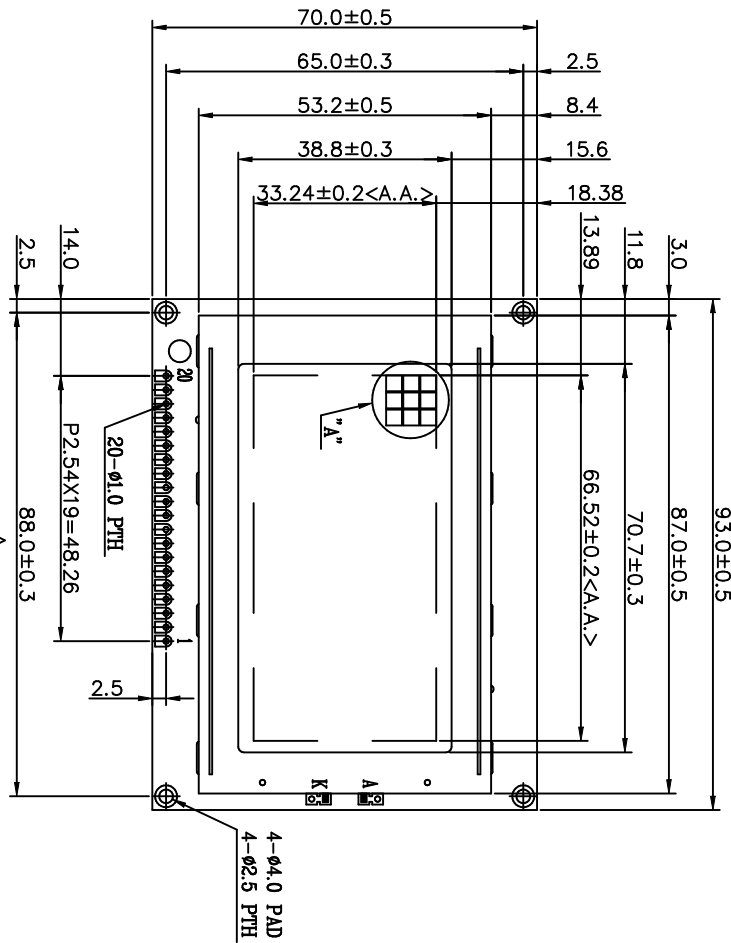
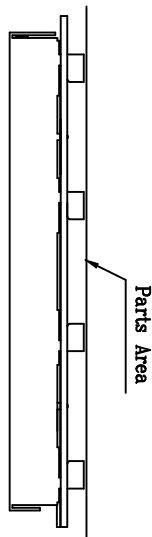

Detail "A"
(Scale 30:1)

Notes :

1. Resolution : 128 x 64 Dots
2. Backlight : LED (Yellow-Green)
3. Frame : SPCC (0.5 t)
4. DC/DC Converter : Built-In

View Direction

Pin No.	Symbol	Level	Function	Pin No.	Symbol	Level	Function
1	VSS	-	Power Supply	10	DB3		Data Bus line
2	VDD	-		11	DB4		
3	V0	-	Operating Voltage for LCD Driving	12	DB5	H/L	
4	D/1	H/L	H : Data Input L : Instruction Code Input	13	DB6		
5	R/W	H/L	H : Data Read (LCM to MPU) L : Data Write (MPU to LCM)	14	DB7		
6	E	H/L	Enable Signal	15	CS1	H	
7	DB0		Data Bus Line	16	CS2	H	
8	DB1	H/L		17	RES	L	
9	DB2			18	VEE	-	
				19	K	-	
				20	A	-	

GENERAL TOLERANCE LIST

DIMENSION	TOLERANCE
L ≤ 6	±0.25 (mm)
6 < L ≤ 18	±0.3 (mm)
18 < L ≤ 50	±0.4 (mm)
50 < L ≤ 125	±0.5 (mm)
125 < L	±0.6 (mm)
ANGLE	±1° (DEG)

南亞塑膠工業股份有限公司
NAN YA PLASTICS CORPORATION

製品圖

LMC97H436AD1.S

APPROVE	NAME	DATE	THIRD ANGLE P.
CHECK			
DESIGN	Compos Chen	95.07.19	SCALE UNIT
DRAWN	Compos Chen	95.07.19	1/1 mm
DWG NO.	M436KD0A		

REV. NO.	DESCRIPTION	DATE	DESIGN	CHECK	APPROVE
△					
△					
△					

THE NOTES OF LCM USING

LCM is easy to damage.

Please follow the notes as bellows, and be careful of handling!

Correct handling

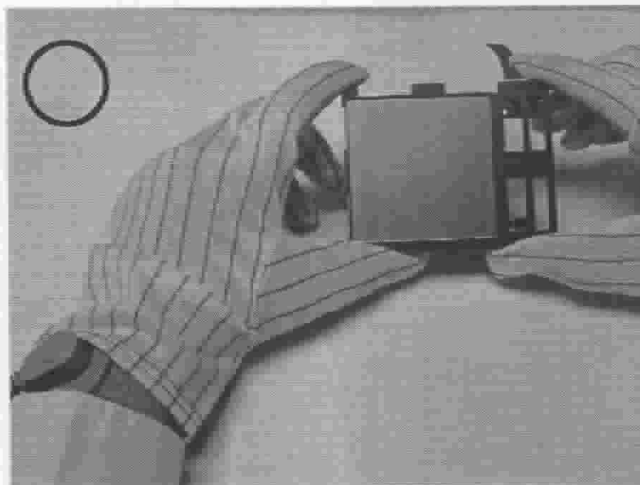
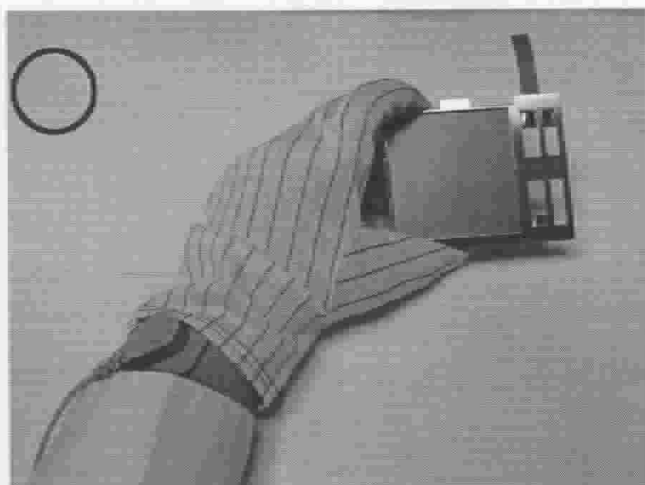

As above picture, please handle with glove by LCM edges and full EOS/ESD protection.

Incorrect handling

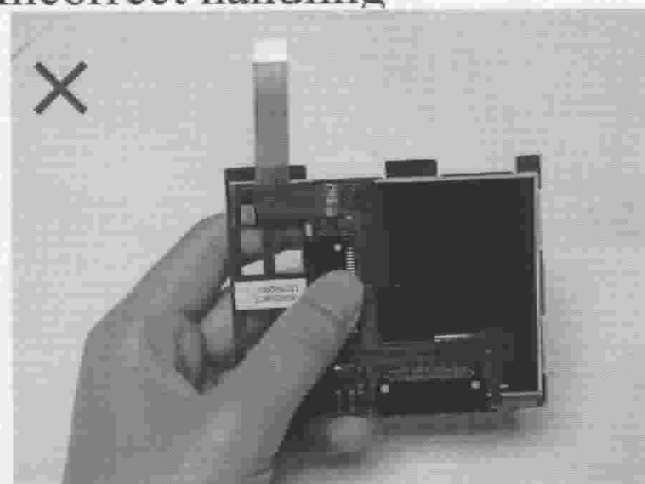

Please don't touch IC directly.

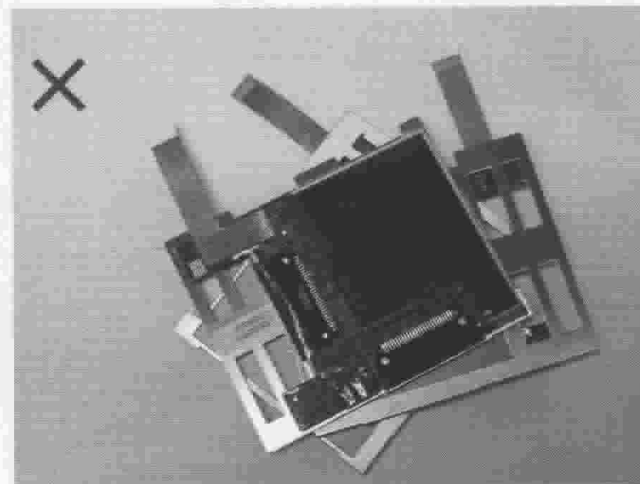

Please don't put one on another LCM.

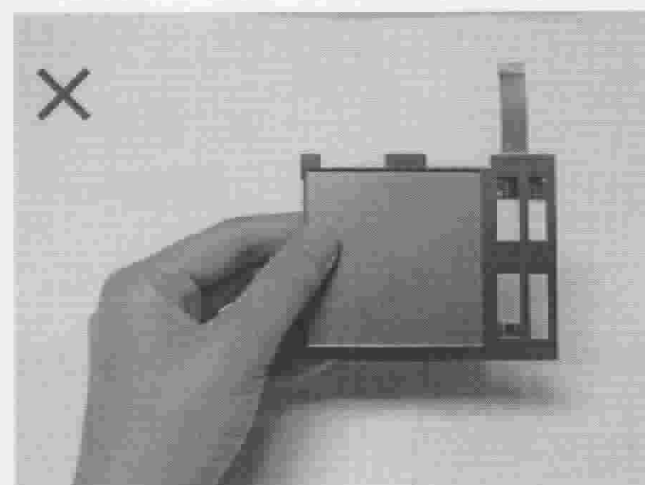

Please don't hold the surface of LCM.

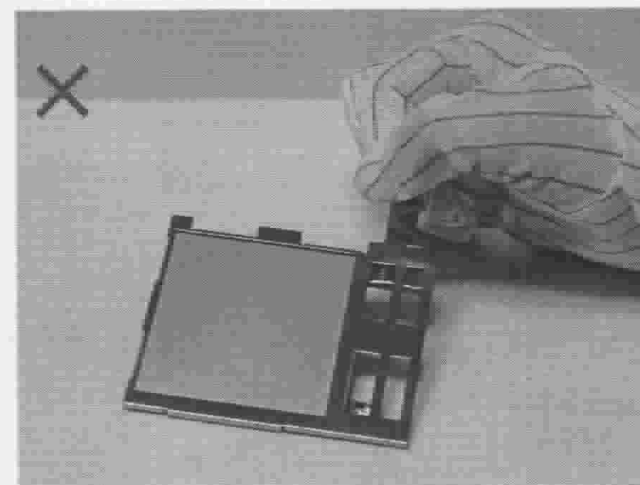

Please don't stretch interface of output.

THE NOTES OF LCD USING

LCD is easy damage.

Please follow notes as bellows, and be careful of handling!

Correct handling

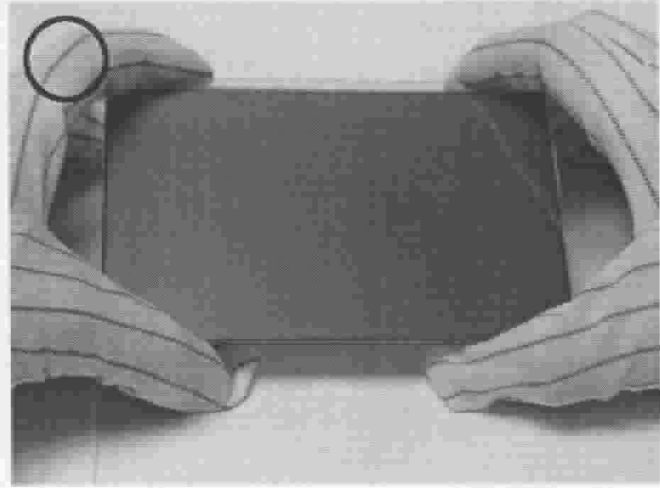
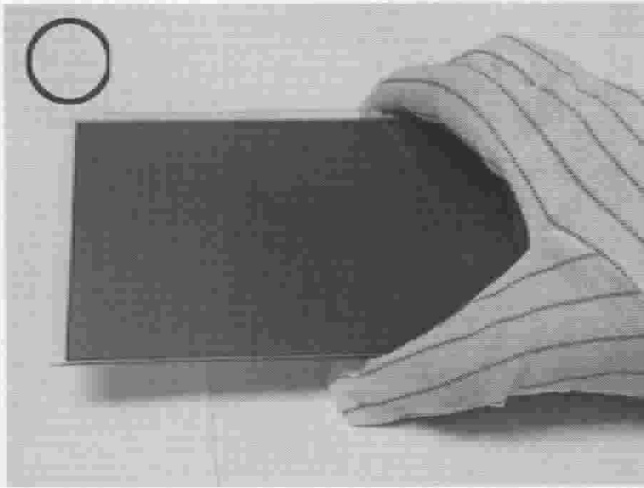

As above picture, please handle with glove by LCD edges and full EOS/ESD protection.

Incorrect handling

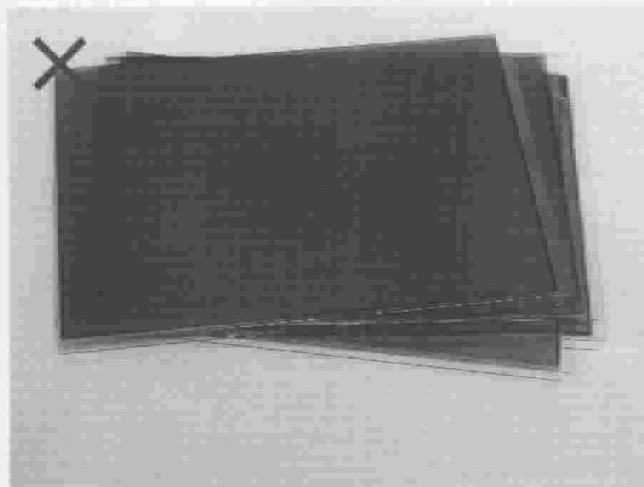

Please don't put one on another LCD.

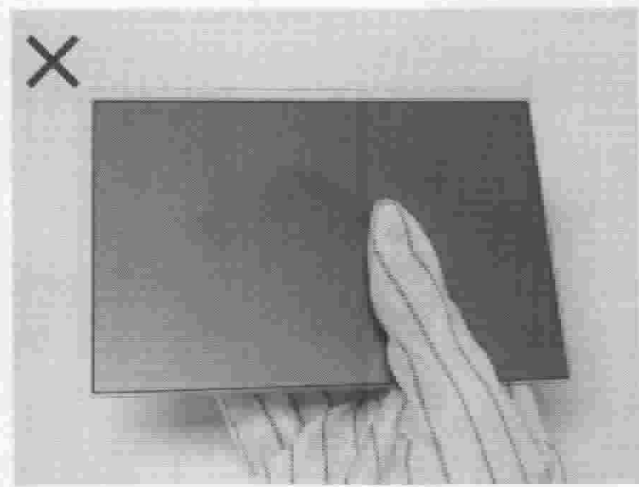

Please don't hold the surface of LCD.

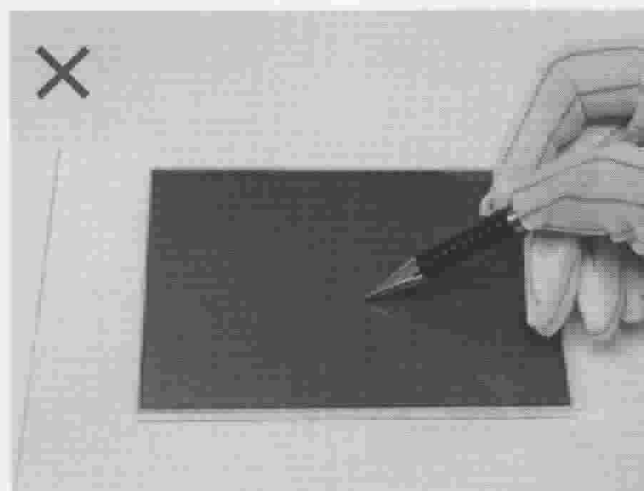

Please don't operate with sharp stick such as sharp pencil.

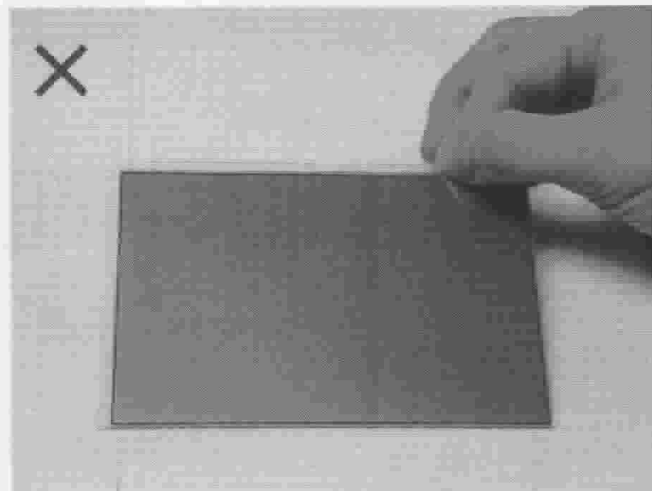

Please don't touch ITO glass without anti-static gloves.

