

NAN YA PLASTICS CORPORATION

SPECIFICATION OF
LCD MODULE
PRODUCT NO.: LMC77H485C7DLLS

SPEC. NO.: LM485-7A-1

CUSTOMER
APPROVED BY
DATE:

LCD DEPARTMENT
ELECTRONIC MATERIALS DIVISION
NAN YA PLASTICS CORPORATION
201, TUNG HWA N. ROAD, TAIPEI
TEL: 886-2-27122211 EXT. 5993~5995
FAX: 886-2-27178253
E-mail: lcdsales@npc.com.tw

EDITED ON : Jun. 28. 2006

Q.C. DEPT.	DESIGN MANAGER	DESIGN CHECK	DESIGNER
			W.R.HSU

1. MECHANICAL DATA

NO	ITEM	CONTENTS	UNIT
1	Product No.	LMC77H485C7DLLS	-
2	Module Size	78.0 (W) x 70.0 (H) x MAX.13.0 (D)	mm
3	Dot Size	0.425 (W) x 0.585 (H)	mm
4	Dot Pitch	0.440 (W) x 0.600 (H)	mm
5	Number of Dots	128 (W) x 64 (H)	Dot
6	Duty	1/64	-
7	LCD Display Mode	STN, Yellow Mode	-
8	Rear Polarizer	Transflective(High Transparency)	-
9	Viewing Direction	6	O'clock
10	Backlight	LED	-
11	DC/DC Converter	Included	-
12	Touch Panel	Excluded	-
13	Weight	70 (Approx.)	g

Note :

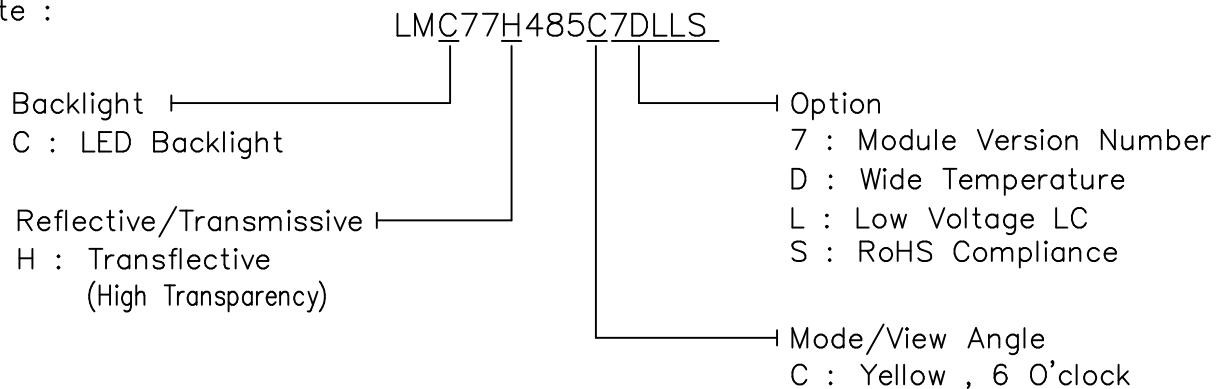

RoHS Compliance.

Nan Ya guarantees that this project doesn't include any materials (6 materials) or includes less than specified quantities which are regulated by RoHS Compliance.

2. ABSOLUTE MAXIMUM RATINGS

(1) ELECTRICAL ABSOLUTE RATINGS

VSS=0V

	SYMBOL	MIN.	MAX.	UNIT	COMMENT
Power Supply for Logic	VCC-GND	-0.3	5.5	V	
Input Voltage	VI	-0.3	VCC	V	
Static Electricity	-	-	-	-	Note 1

Note 1 LCM should be grounded during handling LCM.

(2) ENVIRONMENTAL ABSOLUTE MAXIMUM RATINGS

ITEM	WIDE TEMP.			
	OPERATING		STORAGE	
	MIN.	MAX.	MIN.	MAX.
Ambient Temperature	-20	70	-40	80
Humidity (Without Condensation)	Note 2,4		Note 3,4	

Note 2 $T_a \leq 70^\circ\text{C}$: 75%RH max

Note 3 Please refer to item of reliability test

Note 4 Background color will change slightly depending on ambient temperature.
That phenomenon is reversible.

3. ELECTRICAL CHARACTERISTICS

3-1. ELECTRICAL CHARACTERISTICS OF LCM

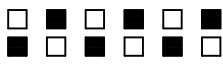
ITEM	SYMBOL	CONDITION	MIN.	TYP.	MAX.	UNIT	
Power Supply for Logic	VCC-GND	-	4.5	5.0	5.5	V	
Input Voltage	VIH	H level	0.8VCC	-	VCC	V	
	VIL	L level	0	-	0.2VCC		
Recommended LC Driving Voltage	VCC-V0 (Vop)	Duty= 1/64	-20°C	9.4	9.7	10.0	V
			0°C	8.9	9.2	9.5	
			25°C	8.5	8.8	9.1	
			50°C	8.1	8.4	8.7	
			70°C	7.7	8.0	8.3	
Power Supply Current	ICC	VCC-GND=5.0V VCC-V0=8.8V Ta=25°C Pattern: 	-	16.6	25	mA	
Surface Luminance of LCM	L	VAK = 4.2V Pattern: Dots All ON	-	6	10	cd/m ²	
		VAK = 4.2V Pattern: Dots All OFF	8	13	-		

3-2.ELECTRICAL CHARACTERISTICS OF BACKLIGHT

Used LED Rating

Temp.=25°C

ITEM	SYMBOL	MIN.	TYP.	MAX.	UNIT	REMARK
Peak forward current	I_P	-	-	550	mA	-
Maximum reverse voltage	V_R	-	-	8	V	-
Applied forward current	I_{AK}	-	220	330	mA	-
Applied forward voltage	V_{AK}	-	4.2	4.6	V	-
LED power consumption	P_F	-	0.9	1.1	W	-
LED life time	L_L	-	40000	-	hrs	at $I_F = 220$ mA (*1)

(*1) LED life time is defined as follows : The final brightness is at 50% of original brightness.

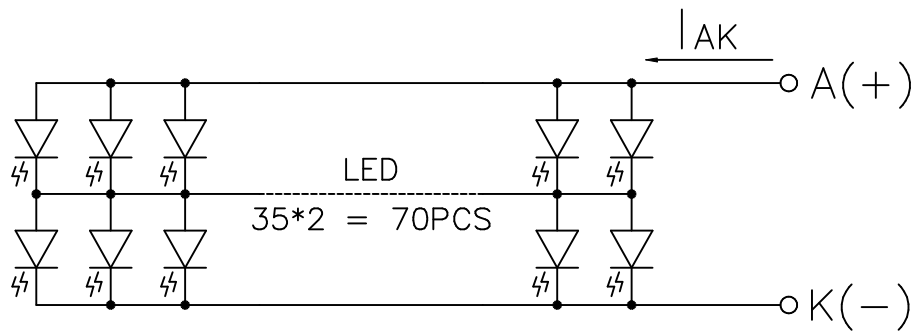

4. OPTICAL CHARACTERISTICS

WIDE TEMPERATURE MODE

AT V_{OP}

ITEM MODE		Cr(Contrast Ratio)										θ (Viewing Angle)		θ (Viewing Angle)	
		-20°C		0°C		25°C		50°C		70°C		25°C		25°C	
		MIN.	TYP.	MIN.	TYP.	MIN.	TYP.	MIN.	TYP.	MIN.	TYP.	MIN.	TYP.	MIN.	TYP.
H	C	3	5	3.5	5.5	3.5	5.5	3	4.5	2	3	-	F: 45 R: 25	-	L: 30 R: 30
NOTE		NOTE 6										NOTE 5			

NOTE :

H : Transflective
C : Yellow, 6 O'clock

AT $\phi=0^\circ$ $\theta=0^\circ$

ITEM	SYMBOL	CONDITION	MIN.	TYP.	MAX.	UNIT	NOTE
Response Time (rise)	Tr	-20℃	3200	4000	6000	ms	NOTE 2
		0℃	720	900	1350		
		25℃	160	200	300		
		50℃	120	150	230		
		70℃	80	100	150		
Response Time (fall)	Tf	-20℃	2000	2500	3750	ms	NOTE 2
		0℃	400	500	750		
		25℃	120	150	230		
		50℃	40	60	90		
		70℃	40	50	80		

(NOTE 1)

Definition of Operation Voltage(Vop)

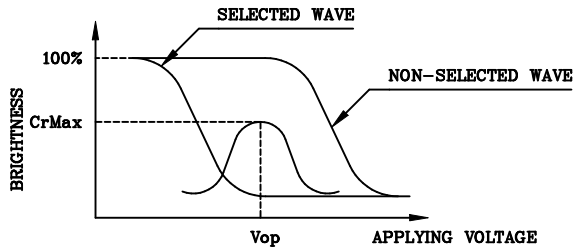

(positive type)

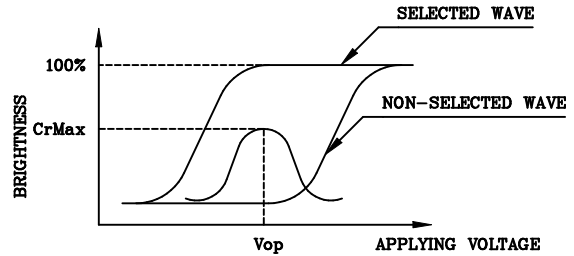

(negative type)

*Conditions

Viewing Angle : 0
Frame Frequency : 70Hz
Applying Waveform : 1/N duty 1/a bias

(NOTE 2)

Definition of Response Time(Tr,Tf)

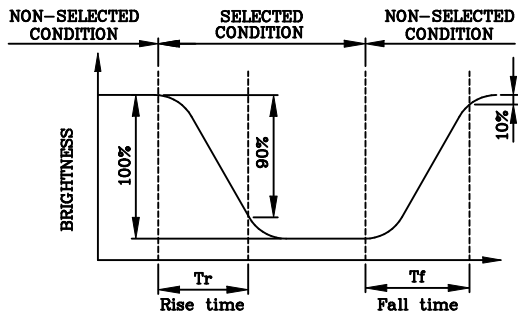

(positive type)

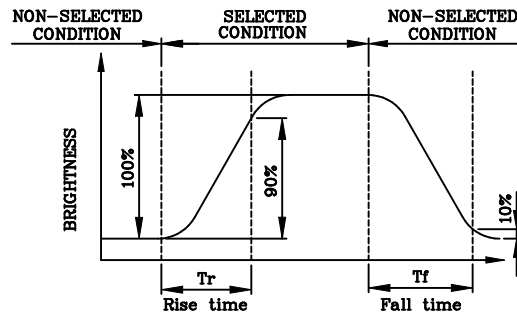

(negative type)

*Conditions

Operating Voltage : Vop
Viewing Angle (θ,φ) : (0,0)
Frame Frequency : 70Hz
Applying Waveform : 1/N duty 1/a bias

(NOTE 3)

Description of Measuring Equipment and Driving Waveforms

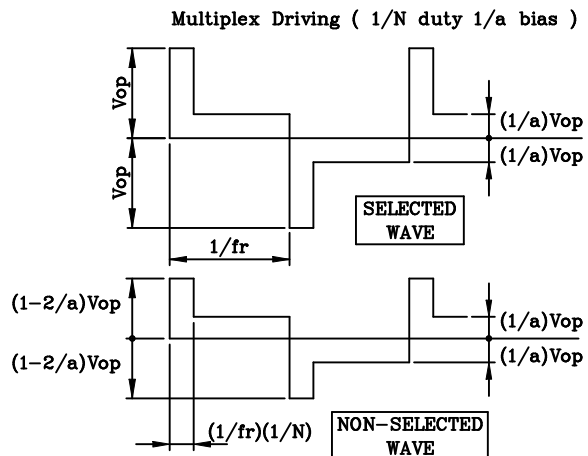
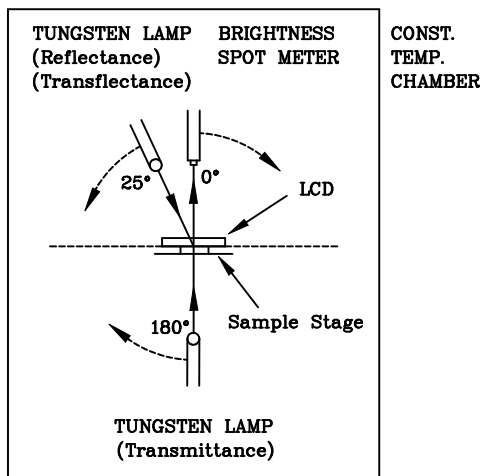

(NOTE 4)

Definition of Viewing Direction

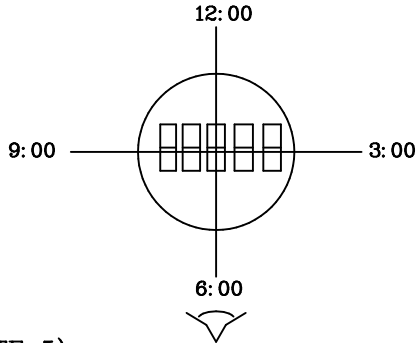

(NOTE 5)

Definition of Viewing Angle

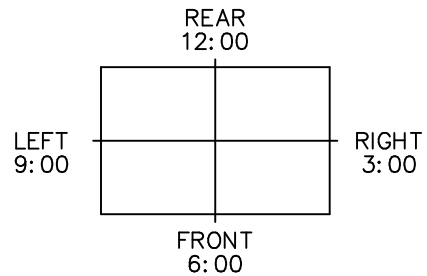
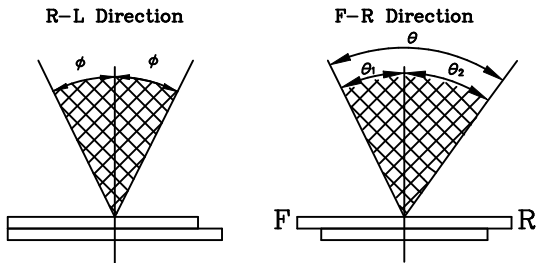

*For This Product
 The Viewing Direction Is 6 O'clock
 So $\theta_1 > \theta_2$

$\theta = \theta_1 + \theta_2$

*Conditions

Operating Voltage : V_{op}
 Frame Frequency : 70Hz
 Applying Waveform : 1/N duty 1/a bias
 Contrast Ratio : larger than 2

(NOTE 6)

Definition of Contrast Ratio (Cr)

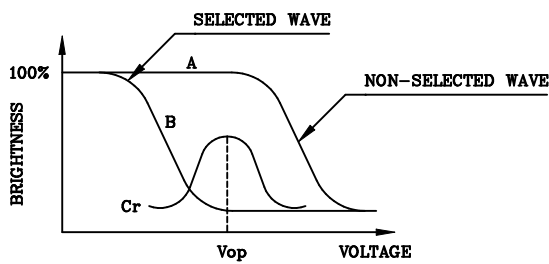

(positive type)

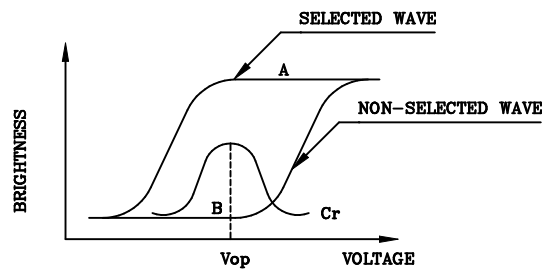

(negative type)

Contrast Ratio : $Cr = A/B$

*Conditions

Viewing Angle : 0
 Frame Frequency : 70Hz
 Applying Waveform : 1/N duty 1/a bias

5. BLOCK DIAGRAM

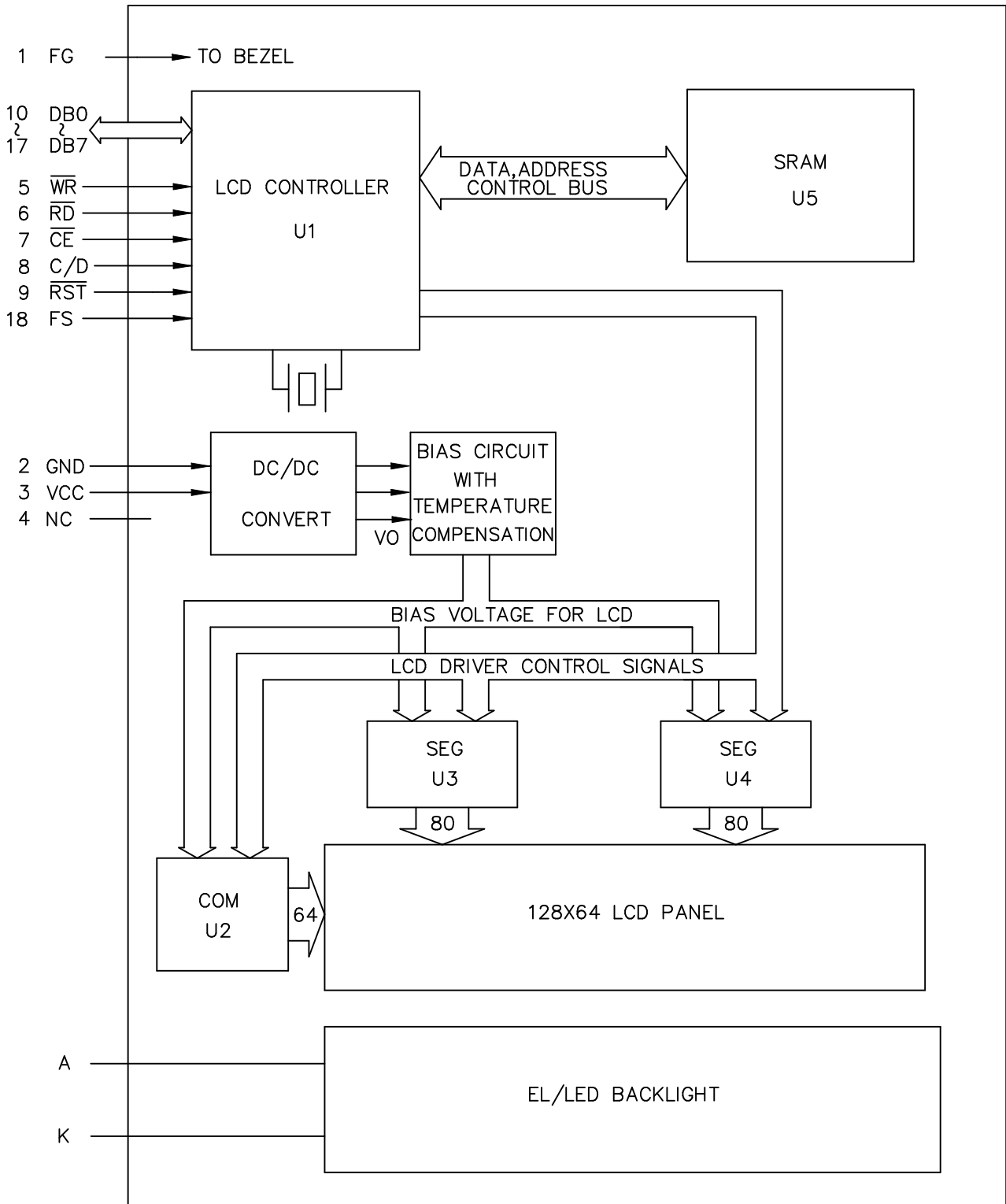

6. INTERNAL PIN CONNECTION

PIN NO.	SYMBOL	FUNCTION
1	FG	FRAME GROUND
2	GND	GROUND
3	VCC	POWER SUPPLY FOR LOGIC(+5V)
4	NC	NO CONNECT
5	\overline{WR}	DATA WRITE TO MODULE WHEN "L"
6	\overline{RD}	DATA READ FROM MODULE WHEN "L"
7	\overline{CE}	CHIP ENABLE OF CONTROLLER WHEN "L"
8	C/D	\overline{WR} ="L",C/D="H" :COMMAND WRITE \overline{WR} ="L",C/D="L" :DATA WRITE \overline{RD} ="L",C/D="H" :STATUS READ \overline{RD} ="L".C/D="L" :DATA READ
9	\overline{RST}	CONTROLLER RESET WHEN "L"
10	DB0	DATA INPUT/OUTPUT(LSB)
11	DB1	DATA INPUT/OUTPUT
12	DB2	DATA INPUT/OUTPUT
13	DB3	DATA INPUT/OUTPUT
14	DB4	DATA INPUT/OUTPUT
15	DB5	DATA INPUT/OUTPUT
16	DB6	DATA INPUT/OUTPUT
17	DB7	DATA INPUT/OUTPUT(MSB)
18	FS	FONT SELECT "H" FOR 6X8 PIXELS/CHARACTER "L" FOR 8X8 PIXELS/CHARACTER
19	A(+)	POWER SUPPLY FOR BACKLIGHT
20	K(-)	

7. POWER SUPPLY

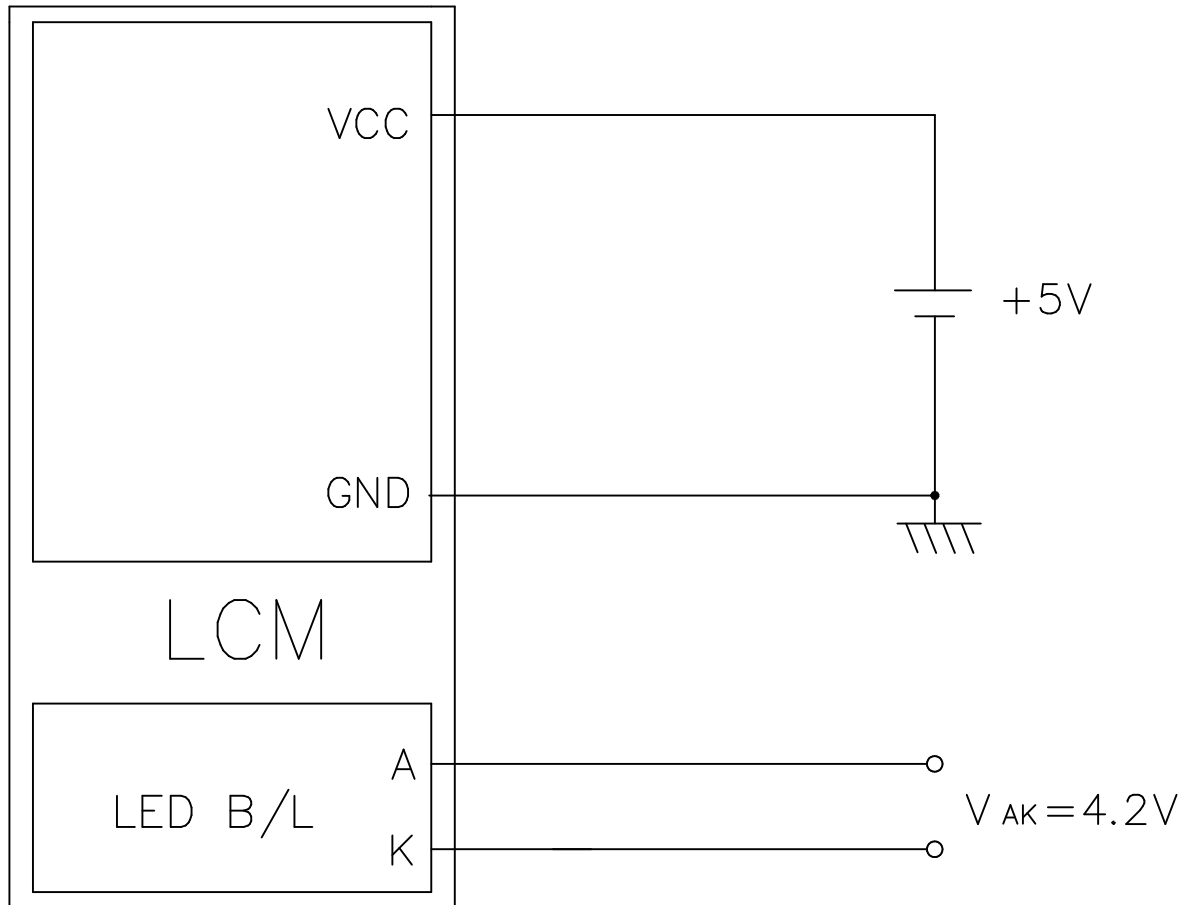

8. TIMING CHARACTERISTICS

8-1. INTERFACE TIMING

ITEM	ITEM	CONDITION	MIN.	MAX.	UNIT
C/D SET UP TIME	t_{CDS}	Fig.	100	-	ns
C/D HOLD TIME	t_{CDH}	Fig.	10	-	ns
$\overline{CE}, \overline{RD}, \overline{WR}$ CLOCK WIDTH	t_{CP}, t_{RP}, t_{WP}	Fig.	80	-	ns
DATA SET UP TIME	t_{DS}	Fig.	80	-	ns
DATA HOLD TIME	t_{DH}	Fig.	40	-	ns
ACCESS TIME	t_{ACC}	Fig.	-	150	ns
DATA OUTPUT HOLD TIME	t_{OH}	Fig.	10	50	ns

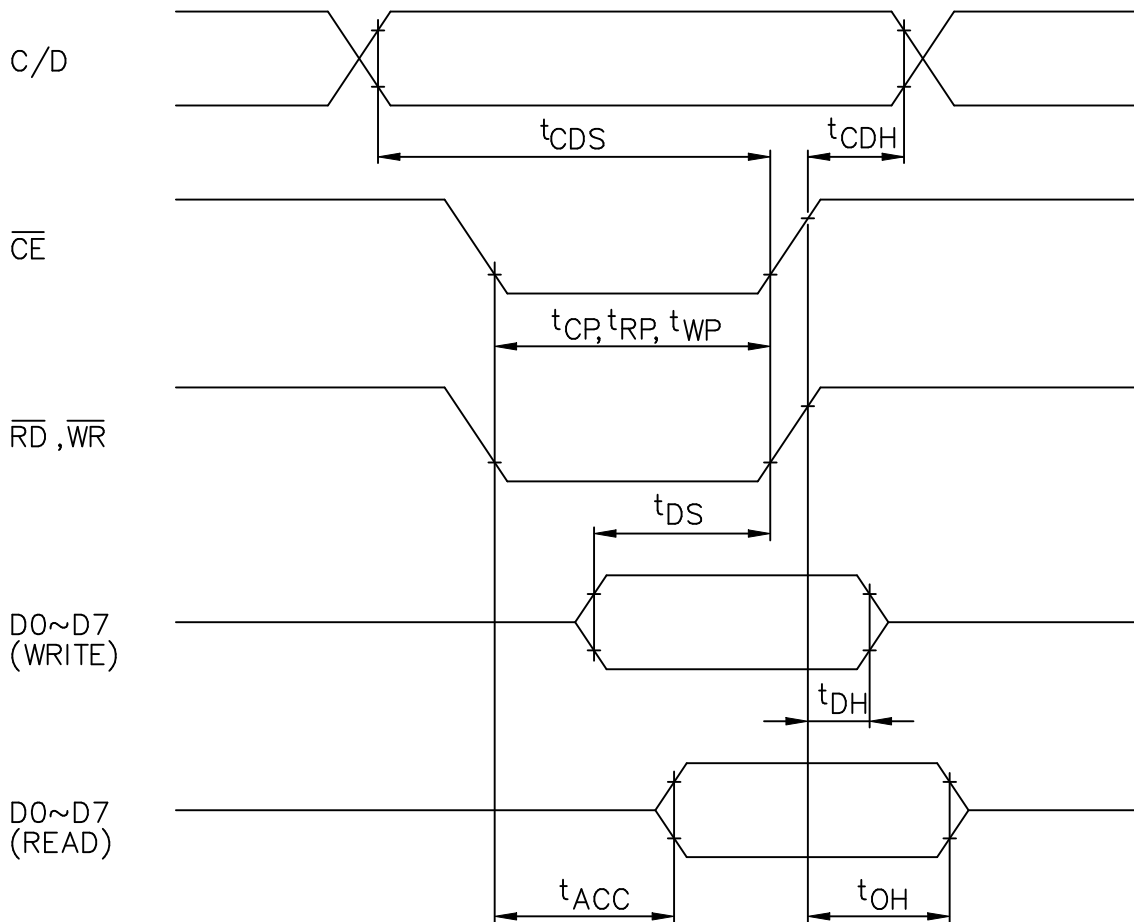
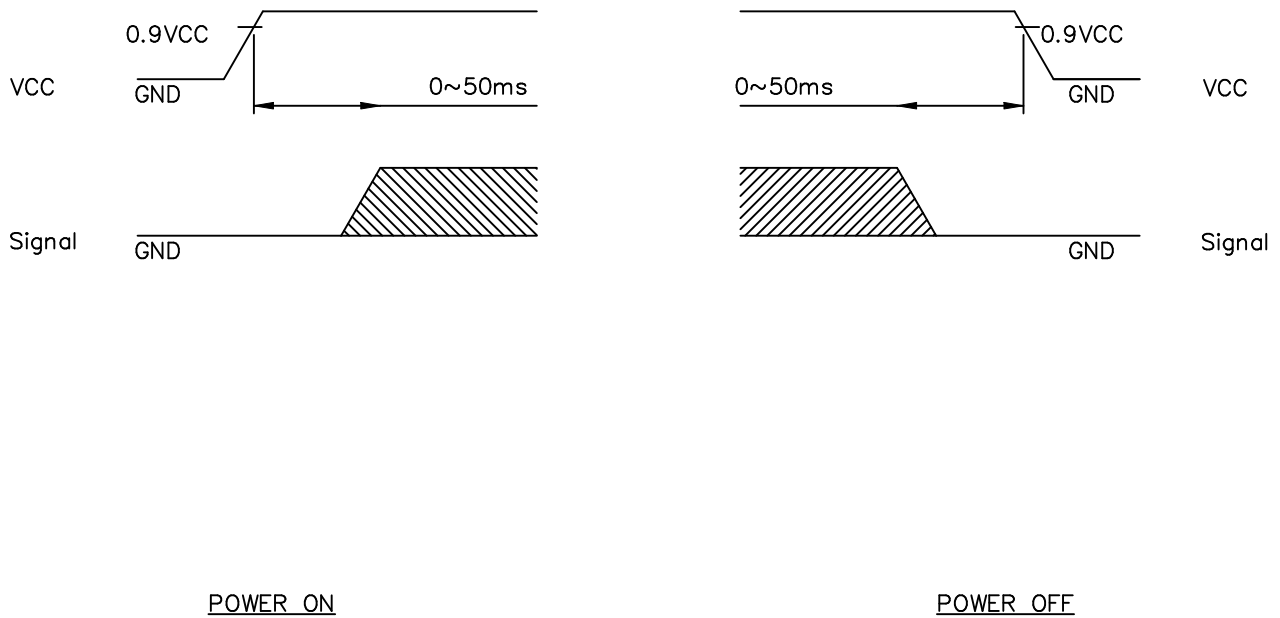

Fig. INTERFACE TIMING CHART

8-2. POWER ON/OFF TIMING CHARACTERISTICS



The missing pixels may occur when the LCM is driven beyond above power interface timing sequence.

8-3.DISPLAY PATTERN

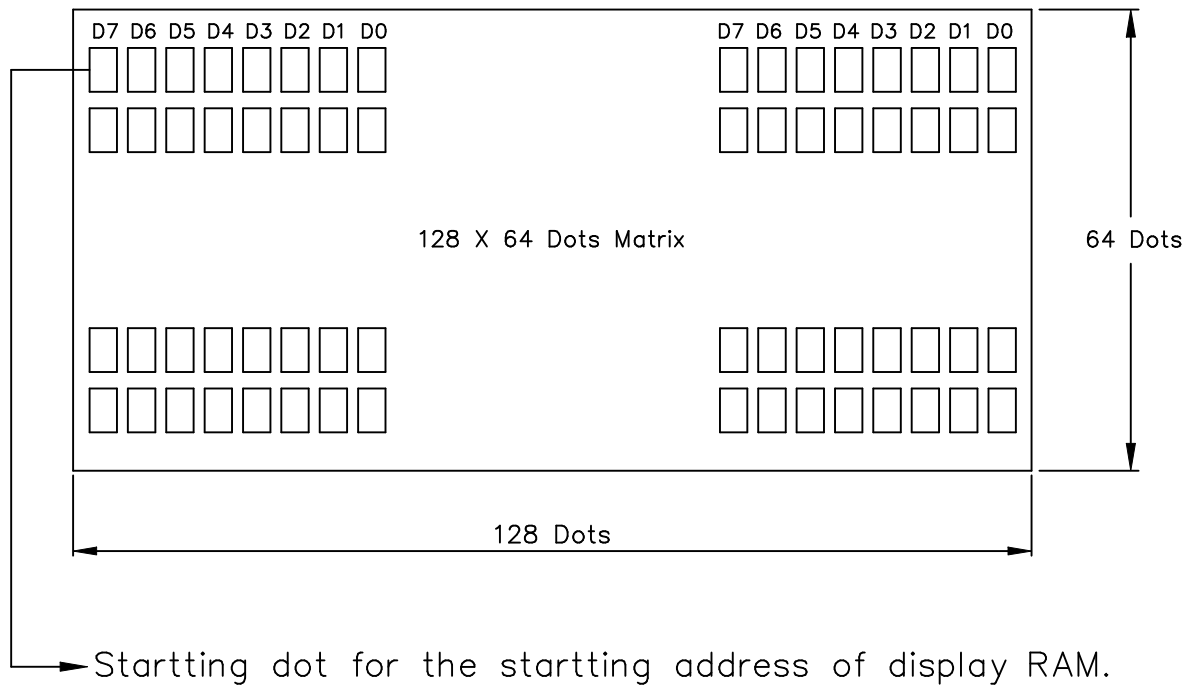

D0~D7 are 8 bits transmitted data ,where D0 is LSB and D7 is MSB.

9. RELIABILITY TEST

WIDE TEMPERATURE RELIABILITY TEST

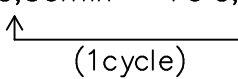
NO	ITEM	CONDITION			STANDARD	NOTE
1	High Temp. Storage	80°C	120Hrs		Appearance without defect	
2	Low Temp. Storage	-40°C	120Hrs		Appearance without defect	
3	High Temp. & High Humi. Storage	60°C 90%RH	120Hrs		Appearance without defect	
4	High Temp. Operating Display	70°C	120Hrs		Appearance without defect	
5	Low Temp. Operating Display	-20°C	120Hrs		Appearance without defect	
6	Thermal Shock	-20°C, 30min → 70°C, 30min  (1cycle)			Appearance without defect	10 cycles

Inspection Provision

1. Purpose

The NAN YA inspection provision provides outgoing inspection provision and its expected quality level based on our outgoing inspection of NAN YA LCD produces.

2. Applicable Scope

The NAN YA inspection provision is applicable to the arrangement in regard to outgoing inspection and quality assurance after outgoing.

3. Technical Terms

3-1 NAN YA Technical Terms

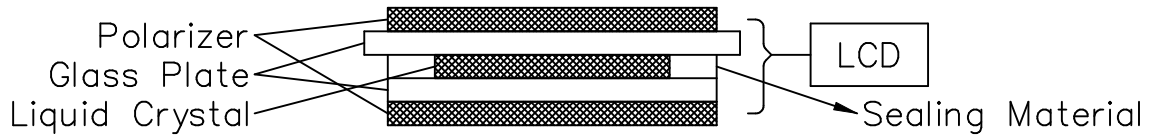

4. Outgoing Inspection

4-1 Inspection Method

MIL-STD-105E Level II Regular inspection

4-2 Inspection Standard

	Item		AQL(%)	Remarks
Major Defect	Dots	Opens Shorts Erroneous operation	0.4	faults which substantially lower the practicality and the initial purpose difficult to achieve.
	Solder appearance	Shorts Loose		
	Cracks	Display surface cracks		

	Dimensions	External from Dimensions	0.4	
Minor Defect	Inside the glass	Black spots	0.65	faults which appear to pose almost no obstacle to the practicality, effective use, and operation.
	Polarizing plate	Scratches, foreign Matter, air bubbles, and peeling		
	Dots	Pinhole, deformation		
	Color tone	Color unevenness		
	Solder appearance	Cold solder Solder projections		

4-3 Inspection Provisions
*Viewing Area Definition

Fig. 1

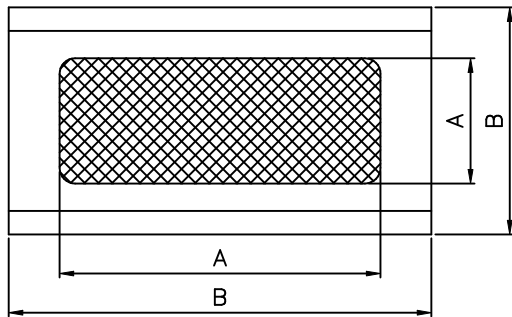

A : Zone Viewing Area
B : Zone Glass Plate Outline

*Inspection place to be 500 to 1000 lux illuminance uniformly without glaring.
The distance between luminous source(daylight fluorescent lamp and cool white fluorescent lamp) and sample to be 30cm to 50cm.

*Test and measurement are performed under the following conditions, unless otherwise specified.

Temperature 20± 15°C
Humidity 65± 20%R.H.
Pressure 860~1060hPa(mmbar)

In case of doubtful judgment, it is performed under the following conditions.

Temperature 20± 2°C
Humidity 65± 5%R.H.
Pressure 860~1060hPa(mmbar)

5.Specification for quality check
5-1 Electrical characteristics

NO.	Item	Criterion
1	Non operational	Fail
2	Miss operating	Fail
3	Missing dot	Fail
4	Contrast irregular	Fail
5	Response time	Within Specified value
6	Backlight turn on/off	Within Specified value

5-2 External Appearance Defect

NO.	Item	Criterion																		
1	Black spots, foreign matter, and white spots (Including light leakage due to pinholes of polarizing plates, etc.)	<p>(1)-1-Spots</p> <table border="1" data-bbox="703 495 1337 775"> <thead> <tr> <th>Average Diameter(mm):D</th> <th>Number of pieces permitted</th> </tr> </thead> <tbody> <tr> <td>$D \leq 0.1$</td> <td>Ignore</td> </tr> <tr> <td>$0.1 < D \leq 0.2$</td> <td>5</td> </tr> <tr> <td>$0.2 < D \leq 0.3$</td> <td>2</td> </tr> <tr> <td>$0.3 < D$</td> <td>0</td> </tr> </tbody> </table> <p>Number of total pieces is set to within 5 pieces.</p> <p>Note that when there are 2 pieces or more, they are not to be concentrated. Set as: Average diameter = (Long diameter + Short diameter)/2</p> <p>(1)-2-Blurred Spots(At lighting condition)</p> <table border="1" data-bbox="703 1189 1337 1424"> <thead> <tr> <th>Average Diameter(mm):D</th> <th>Number of pieces permitted</th> </tr> </thead> <tbody> <tr> <td>$D \leq 0.3$</td> <td>Ignore</td> </tr> <tr> <td>$0.3 < D \leq 0.75$</td> <td>5</td> </tr> <tr> <td>$0.75 < D$</td> <td>0</td> </tr> </tbody> </table> <p>Number of total pieces is set to within 5 pieces.</p> <p>Note that when there are 2 pieces or more, they are not to be concentrated. Set as: Average diameter = (Long diameter + Short diameter)/2</p>	Average Diameter(mm):D	Number of pieces permitted	$D \leq 0.1$	Ignore	$0.1 < D \leq 0.2$	5	$0.2 < D \leq 0.3$	2	$0.3 < D$	0	Average Diameter(mm):D	Number of pieces permitted	$D \leq 0.3$	Ignore	$0.3 < D \leq 0.75$	5	$0.75 < D$	0
Average Diameter(mm):D	Number of pieces permitted																			
$D \leq 0.1$	Ignore																			
$0.1 < D \leq 0.2$	5																			
$0.2 < D \leq 0.3$	2																			
$0.3 < D$	0																			
Average Diameter(mm):D	Number of pieces permitted																			
$D \leq 0.3$	Ignore																			
$0.3 < D \leq 0.75$	5																			
$0.75 < D$	0																			

1	Line	<p>(1)-1-Lines</p> <table border="1" data-bbox="703 443 1431 721"> <thead> <tr> <th>Width(mm): W</th> <th>Length(mm): L</th> <th>Number of pieces permitted</th> </tr> </thead> <tbody> <tr> <td>$W \leq 0.03$</td> <td>Ignore</td> <td>Ignore</td> </tr> <tr> <td>$0.03 < W \leq 0.08$</td> <td>$L \leq 4$</td> <td>2</td> </tr> <tr> <td>$0.08 < W \leq 0.1$</td> <td>$L \leq 1$</td> <td>1</td> </tr> </tbody> </table> <p>Object exceeding 0.1mm follow the standards of the spots form. Note that when there are 2 pieces or more, they are not to be concentrated.</p> <p>(1)-2-Blurred Lines(At lighting condition)</p> <table border="1" data-bbox="703 1021 1431 1299"> <thead> <tr> <th>Width(mm): W</th> <th>Length(mm): L</th> <th>Number of pieces permitted</th> </tr> </thead> <tbody> <tr> <td>$W \leq 0.03$</td> <td>Ignore</td> <td>Ignore</td> </tr> <tr> <td>$0.03 < W \leq 0.08$</td> <td>$L \leq 3$</td> <td>6</td> </tr> <tr> <td>$0.08 < W$</td> <td>$3 < L$</td> <td>None</td> </tr> </tbody> </table> <p>Object exceeding 0.1mm follow the standards of the spots form. Note that when there are 2 pieces or more, they are not to be concentrated.</p>	Width(mm): W	Length(mm): L	Number of pieces permitted	$W \leq 0.03$	Ignore	Ignore	$0.03 < W \leq 0.08$	$L \leq 4$	2	$0.08 < W \leq 0.1$	$L \leq 1$	1	Width(mm): W	Length(mm): L	Number of pieces permitted	$W \leq 0.03$	Ignore	Ignore	$0.03 < W \leq 0.08$	$L \leq 3$	6	$0.08 < W$	$3 < L$	None
Width(mm): W	Length(mm): L	Number of pieces permitted																								
$W \leq 0.03$	Ignore	Ignore																								
$0.03 < W \leq 0.08$	$L \leq 4$	2																								
$0.08 < W \leq 0.1$	$L \leq 1$	1																								
Width(mm): W	Length(mm): L	Number of pieces permitted																								
$W \leq 0.03$	Ignore	Ignore																								
$0.03 < W \leq 0.08$	$L \leq 3$	6																								
$0.08 < W$	$3 < L$	None																								
2	Scratches(Glass, reflection plates, and polarizing plates)	In accordance with black spots. (At non lighting condition)																								
3	Color irregular	Not remarkable color irregular.																								

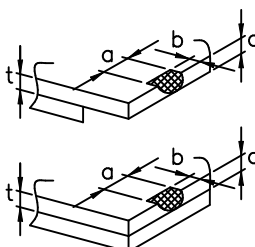
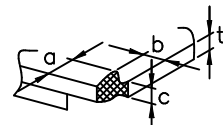
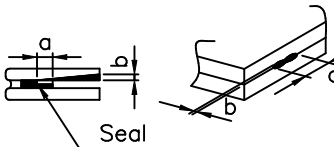
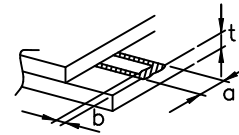
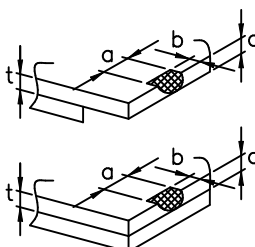
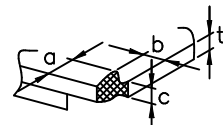
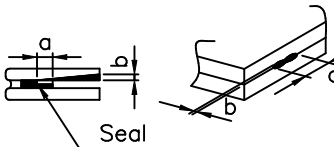
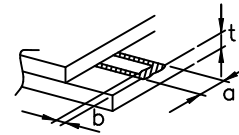
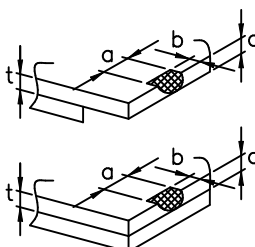
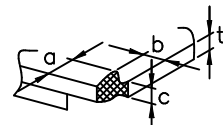
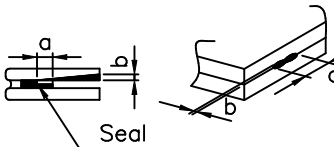
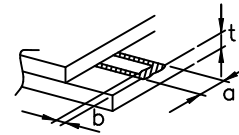
4	Air bubbles polarizing plates, and reflection plates	<table border="1" data-bbox="702 392 1209 678"> <tr> <td data-bbox="702 392 954 537">Average Diameter (mm): D</td> <td data-bbox="954 392 1209 537">Number of pieces permitted</td> <td data-bbox="1209 392 1450 678" rowspan="2">Average diameter = (Long diameter + Short diameter)/2</td> </tr> <tr> <td data-bbox="702 537 954 678">D ≤ 0.3 0.3 < D</td> <td data-bbox="954 537 1209 678">Ignore 0</td> </tr> </table> <p data-bbox="702 694 1450 772">Note that when there are 4 pieces or more, they are not to be concentrated.</p>		Average Diameter (mm): D	Number of pieces permitted	Average diameter = (Long diameter + Short diameter)/2	D ≤ 0.3 0.3 < D	Ignore 0					
Average Diameter (mm): D	Number of pieces permitted	Average diameter = (Long diameter + Short diameter)/2											
D ≤ 0.3 0.3 < D	Ignore 0												
5	Cracks	<table border="1" data-bbox="654 784 1450 1946"> <tr> <td data-bbox="654 784 1050 1164"> <p data-bbox="654 784 1050 828">(1) General crack</p>  </td> <td data-bbox="1050 784 1450 1164"> <p data-bbox="1050 784 1450 828">$a \leq 5$</p> <p data-bbox="1050 828 1450 873">$b \leq 2$</p> <p data-bbox="1050 873 1450 918">$c \leq t$</p> <p data-bbox="1050 918 1450 1164">Where, a and b are ignored when less than or equal to 0.5 The numbers of pieces are set at up to 5 pieces.</p> </td> </tr> <tr> <td data-bbox="654 1164 1050 1355"> <p data-bbox="654 1164 1050 1209">(2) Corner crack</p>  </td> <td data-bbox="1050 1164 1450 1355"> <p data-bbox="1050 1164 1450 1209">$a \leq 2.5$</p> <p data-bbox="1050 1209 1450 1254">$b \leq 2.5$</p> <p data-bbox="1050 1254 1450 1299">$c \leq t$</p> <p data-bbox="1050 1299 1450 1355">$a + b \leq 4$</p> </td> </tr> <tr> <td data-bbox="654 1355 1050 1624"> <p data-bbox="654 1355 1050 1400">(3) Seal portion crack</p>  </td> <td data-bbox="1050 1355 1450 1624"> <p data-bbox="1050 1355 1450 1400">$a \leq \text{The seal width} \times 1/3$</p> <p data-bbox="1050 1400 1450 1444">$b \leq t \times 2/3$</p> <p data-bbox="1050 1444 1450 1489">$c \leq 5$</p> <p data-bbox="1050 1489 1450 1624">The numbers of pieces are set at up to 5 pieces.</p> </td> </tr> <tr> <td data-bbox="654 1624 1050 1848"> <p data-bbox="654 1624 1050 1668">(4) ITO Pin crack</p>  </td> <td data-bbox="1050 1624 1450 1848"> <p data-bbox="1050 1624 1450 1668">$a \leq 5$</p> <p data-bbox="1050 1668 1450 1713">$b \leq 1/3 \text{ pin length}$</p> <p data-bbox="1050 1713 1450 1758">$c \leq t$</p> </td> </tr> <tr> <td data-bbox="654 1848 1050 1946"> <p data-bbox="654 1848 1050 1892">(5) Progressive cracks</p> </td> <td data-bbox="1050 1848 1450 1946"> <p data-bbox="1050 1848 1450 1946">All taken to be unacceptable.</p> </td> </tr> </table>		<p data-bbox="654 784 1050 828">(1) General crack</p> 	<p data-bbox="1050 784 1450 828">$a \leq 5$</p> <p data-bbox="1050 828 1450 873">$b \leq 2$</p> <p data-bbox="1050 873 1450 918">$c \leq t$</p> <p data-bbox="1050 918 1450 1164">Where, a and b are ignored when less than or equal to 0.5 The numbers of pieces are set at up to 5 pieces.</p>	<p data-bbox="654 1164 1050 1209">(2) Corner crack</p> 	<p data-bbox="1050 1164 1450 1209">$a \leq 2.5$</p> <p data-bbox="1050 1209 1450 1254">$b \leq 2.5$</p> <p data-bbox="1050 1254 1450 1299">$c \leq t$</p> <p data-bbox="1050 1299 1450 1355">$a + b \leq 4$</p>	<p data-bbox="654 1355 1050 1400">(3) Seal portion crack</p> 	<p data-bbox="1050 1355 1450 1400">$a \leq \text{The seal width} \times 1/3$</p> <p data-bbox="1050 1400 1450 1444">$b \leq t \times 2/3$</p> <p data-bbox="1050 1444 1450 1489">$c \leq 5$</p> <p data-bbox="1050 1489 1450 1624">The numbers of pieces are set at up to 5 pieces.</p>	<p data-bbox="654 1624 1050 1668">(4) ITO Pin crack</p> 	<p data-bbox="1050 1624 1450 1668">$a \leq 5$</p> <p data-bbox="1050 1668 1450 1713">$b \leq 1/3 \text{ pin length}$</p> <p data-bbox="1050 1713 1450 1758">$c \leq t$</p>	<p data-bbox="654 1848 1050 1892">(5) Progressive cracks</p>	<p data-bbox="1050 1848 1450 1946">All taken to be unacceptable.</p>
<p data-bbox="654 784 1050 828">(1) General crack</p> 	<p data-bbox="1050 784 1450 828">$a \leq 5$</p> <p data-bbox="1050 828 1450 873">$b \leq 2$</p> <p data-bbox="1050 873 1450 918">$c \leq t$</p> <p data-bbox="1050 918 1450 1164">Where, a and b are ignored when less than or equal to 0.5 The numbers of pieces are set at up to 5 pieces.</p>												
<p data-bbox="654 1164 1050 1209">(2) Corner crack</p> 	<p data-bbox="1050 1164 1450 1209">$a \leq 2.5$</p> <p data-bbox="1050 1209 1450 1254">$b \leq 2.5$</p> <p data-bbox="1050 1254 1450 1299">$c \leq t$</p> <p data-bbox="1050 1299 1450 1355">$a + b \leq 4$</p>												
<p data-bbox="654 1355 1050 1400">(3) Seal portion crack</p> 	<p data-bbox="1050 1355 1450 1400">$a \leq \text{The seal width} \times 1/3$</p> <p data-bbox="1050 1400 1450 1444">$b \leq t \times 2/3$</p> <p data-bbox="1050 1444 1450 1489">$c \leq 5$</p> <p data-bbox="1050 1489 1450 1624">The numbers of pieces are set at up to 5 pieces.</p>												
<p data-bbox="654 1624 1050 1668">(4) ITO Pin crack</p> 	<p data-bbox="1050 1624 1450 1668">$a \leq 5$</p> <p data-bbox="1050 1668 1450 1713">$b \leq 1/3 \text{ pin length}$</p> <p data-bbox="1050 1713 1450 1758">$c \leq t$</p>												
<p data-bbox="654 1848 1050 1892">(5) Progressive cracks</p>	<p data-bbox="1050 1848 1450 1946">All taken to be unacceptable.</p>												

6	Outer dimensions	Should be within the tolerance.
7	Newton ring(touch panel)	Orbicular of interference fringes is not allowed in the optimum contrast within the active area under viewing angle.
8	Soldering	Should be no defective soldering such as shorting, loose terminal cold solder, peeling of printed circuit board pattern, improper mounting position, etc.

5-3 Dot Appearance Defect

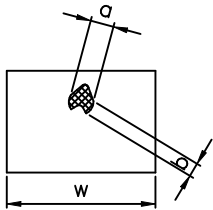
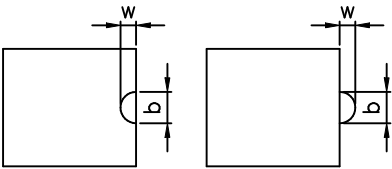
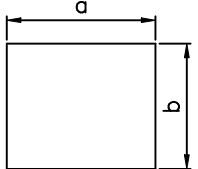
NO.	Item	Criteria
1	Pinhole	 <p>Dot display a and b are each $\leq 0.2\text{mm}$ The overall total is taken be with in 10 units. Note that they are not to be concentrated.</p>
2	Missing	 <p>Dot display a and b are each $\leq 0.2\text{mm}$ The overall total is taken to be with in 10 units.</p>
3	Thick and thin display	 <p>Taken to be within $\pm 1.5\%$ of display character width(a) and height(b).</p>

NOTICE:

- SAFETY

- 1.If the LCD panel breaks, be careful not to get the liquid crystal to touch your skin.
- 2.If the liquid crystal touches your skin or clothes, please wash it off immediately by using soap and water.

- HANDLING

- 1.Avoid static electricity which can damage the CMOS LSI.
- 2.Do not remove the panel or frame from the module.
- 3.The polarizing plate of the display is very fragile. So, please handle it very carefully.
- 4.Do not wipe the polarizing plate with a dry cloth, as it may easily scratch the surface of plate.
- 5.Do not use ketonics solvent & Aromatic solvent. Use a soft cloth soaked with a cleaning naphtha solvent.

- STORAGE

- 1.Store the panel or module in a dark place where the temperature is $25^{\circ}\text{C}\pm 5^{\circ}\text{C}$ and the humidity is below 65% RH.
- 2.Do not place the module near organics solvents or corrosive gases.
- 3.Do not crush, shake, or jolt the module.

- TERMS OF WARRANT

- 1.Acceptance inspection period
The period is within one month after the arrival of contracted commodity at the buyer's factory site.
- 2.Applicable warrant period
The period is within twelve months since the date of shipping out under normal using and storage conditions.

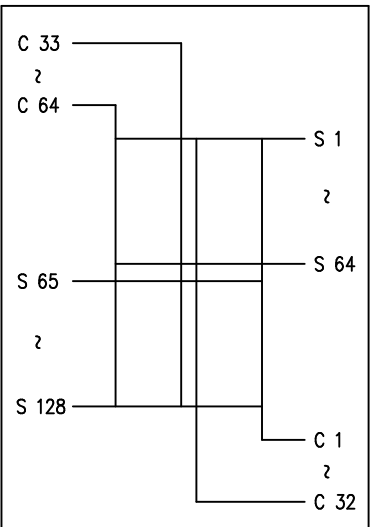

PANEL LAYOUT DIAGRAM

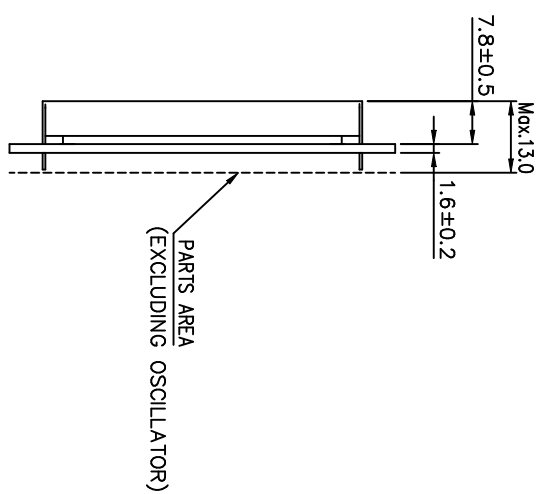
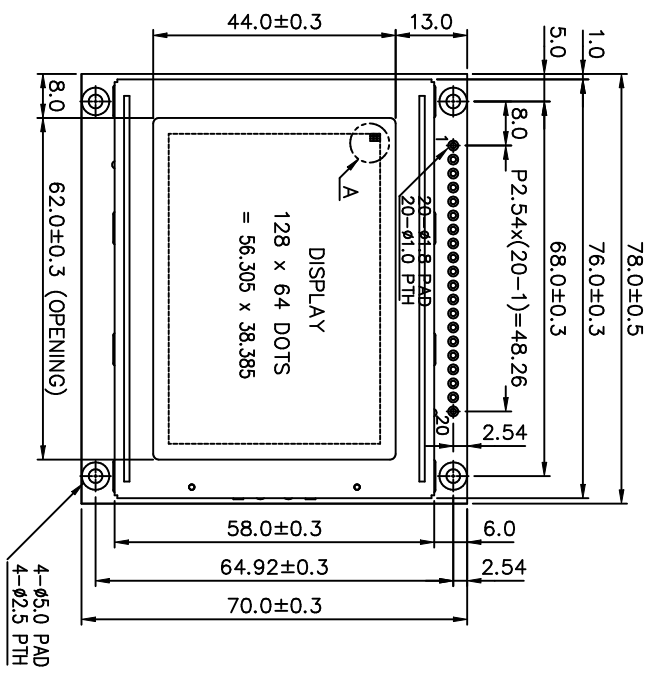

VIEW DIRECTION

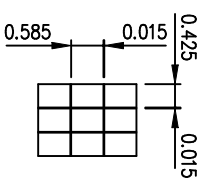
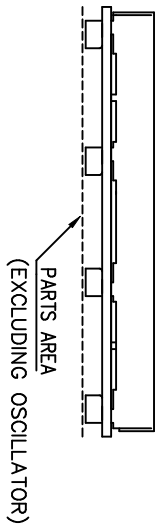

PIN NO.	SYMBOL	FUNCTION
1	F6	FRAME GROUND
2	GND	GROUND
3	VCC	POWER SUPPLY FOR LOGIC(+5V)
4	NC	NO CONNECT
5	WR	DATA WRITE TO MODULE WHEN "L"
6	RD	DATA READ FROM MODULE WHEN "L"
7	CE	CHIP ENABLE OF CONTROLLER WHEN "L"
8	C/D	WR="L",C/D="H": COMMAND WRITE WR="L",C/D="L": DATA WRITE RD="L",C/D="H": STATUS READ RD="L",C/D="L": DATA READ
9	RST	CONTROLLER RESET WHEN "L"
10	DB0	DATA INPUT/OUTPUT(LSB)
11	DB1	DATA INPUT/OUTPUT
12	DB2	DATA INPUT/OUTPUT
13	DB3	DATA INPUT/OUTPUT
14	DB4	DATA INPUT/OUTPUT
15	DB5	DATA INPUT/OUTPUT
16	DB6	DATA INPUT/OUTPUT
17	DB7	DATA INPUT/OUTPUT(MSB)
18	FS	FONT SELECT "H" FOR 6X8 PIXELS/CHARACTER "L" FOR 8X8 PIXELS/CHARACTER
19	A(+)	POWER SUPPLY FOR BACKLIGHT
20	K(-)	

NOTES :

1. RESOLUTION : 128 x 64 DOTS
2. BACK-LIGHT : LED (YELLOW GREEN)
3. TOLERANCE NO SPECIFIED : ± 0.5 mm
4. BUILD-IN DC/DC CONVERT
5. WITH TEMPERATURE RESPONSE FOR BIAS CIRCUIT

REV. NO.	DESCRIPTION	DATE	DESIGN	CHECK	APPROVE
△	Modified the product No.	95.06.23	Compos Chen		
△					
△					
△					

南亞塑膠工業股份有限公司
NAN YA PLASTICS CORPORATION

ALMC77H485C7D1L5

APPROVE	NAME	DATE	THIRD ANGLE P.
APPROVE	TONY CHOU	95.04.17	
CHECK	Y. C. Liu	95.04.11	
DESIGN	Compos Chen	95.04.11	SCALE UNIT
DRAWN	Compos Chen	95.04.11	1/1 mm

THE NOTES OF LCM USING

LCM is easy to damage.

Please follow the notes as bellows, and be careful of handling!

Correct handling

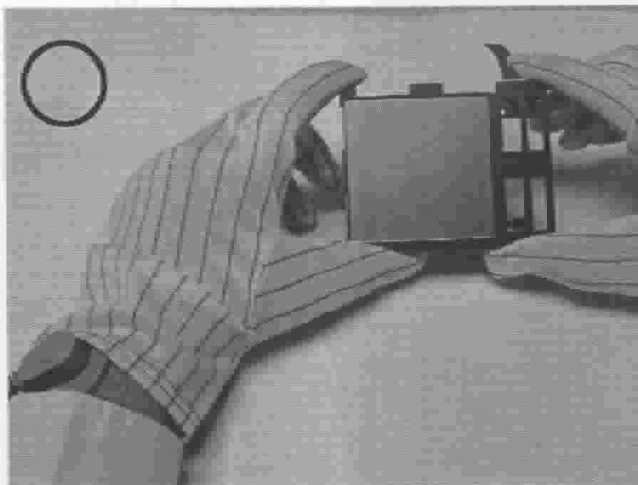
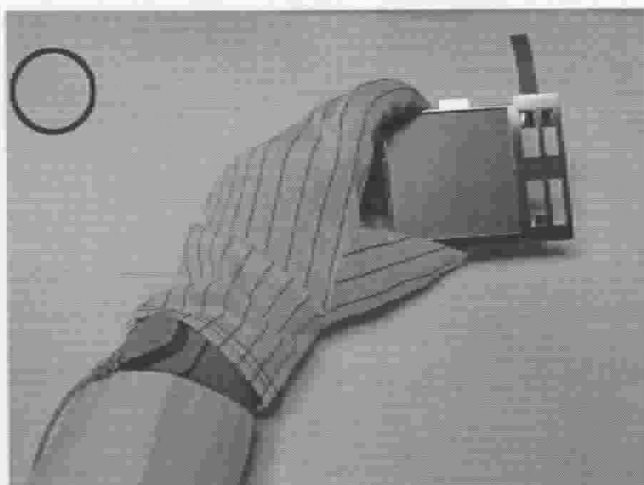

As above picture, please handle with glove by LCM edges and full EOS/ESD protection.

Incorrect handling

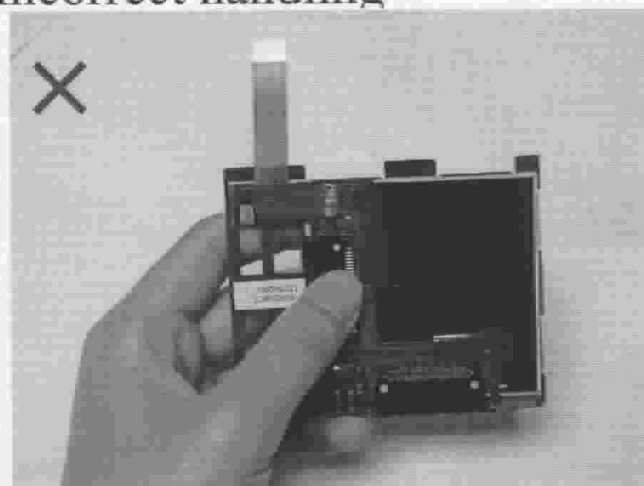

Please don't touch IC directly.

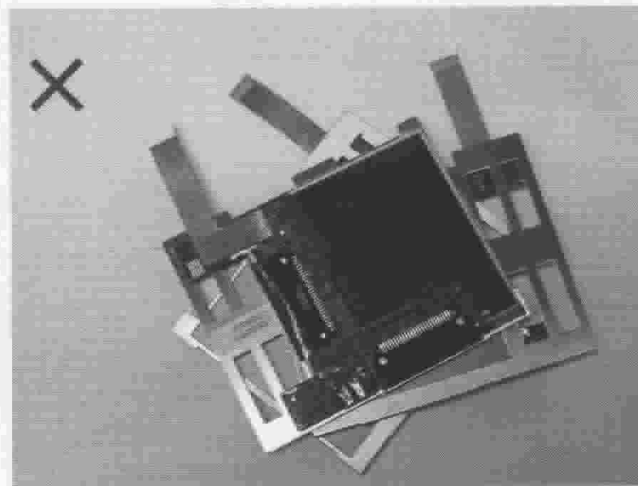

Please don't put one on another LCM.

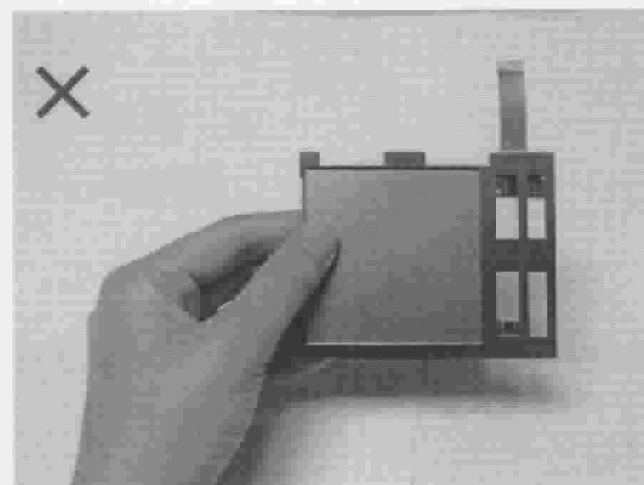

Please don't hold the surface of LCM.

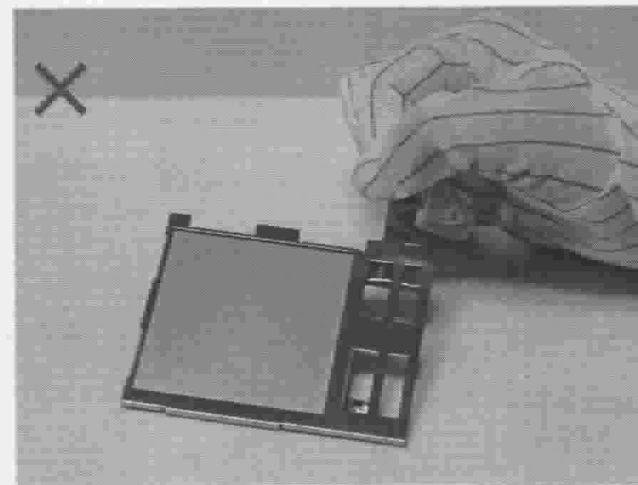

Please don't stretch interface of output.

THE NOTES OF LCD USING

LCD is easy damage.

Please follow notes as bellows, and be careful of handling!

Correct handling

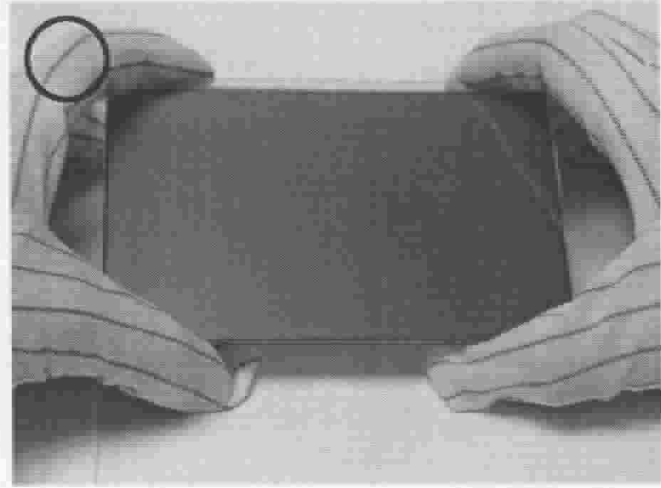
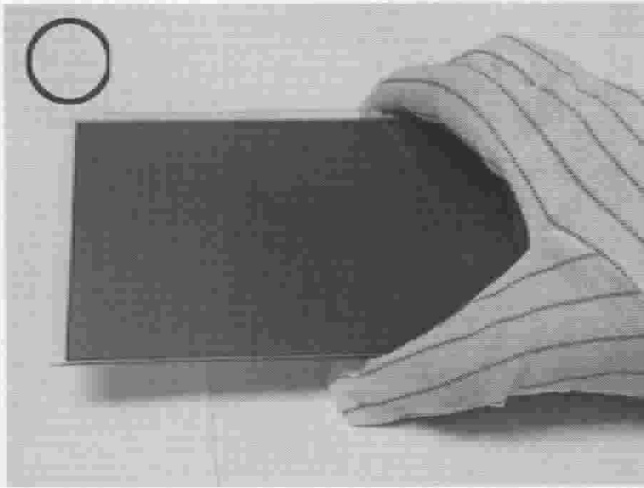

As above picture, please handle with glove by LCD edges and full EOS/ESD protection.

Incorrect handling

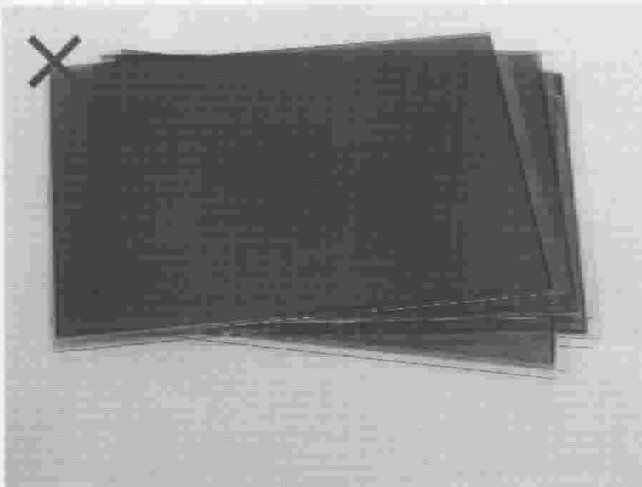

Please don't put one on another LCD.

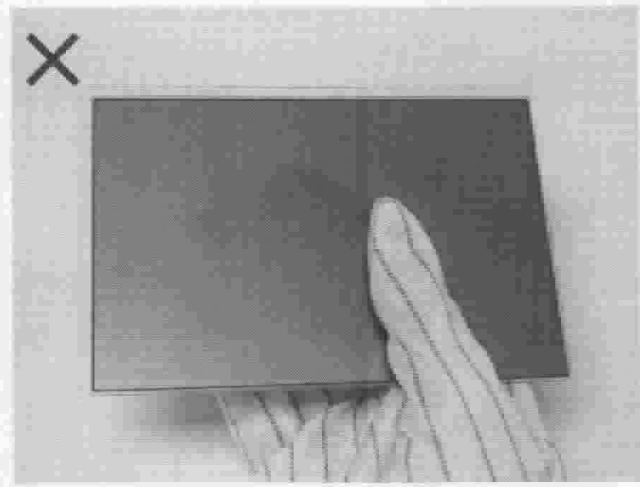

Please don't hold the surface of LCD.

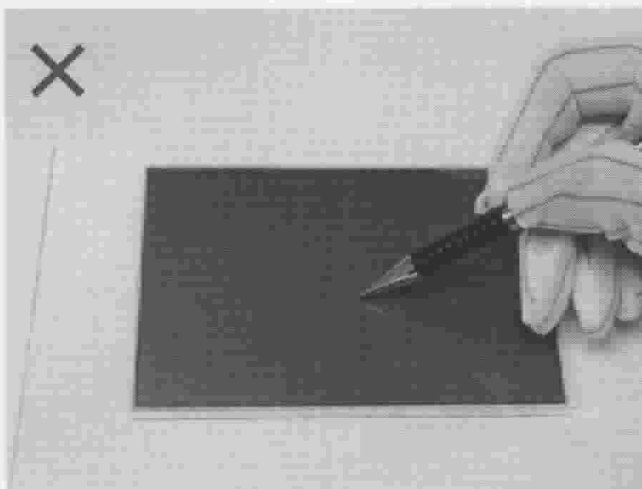

Please don't operate with sharp stick such as sharp pencil.

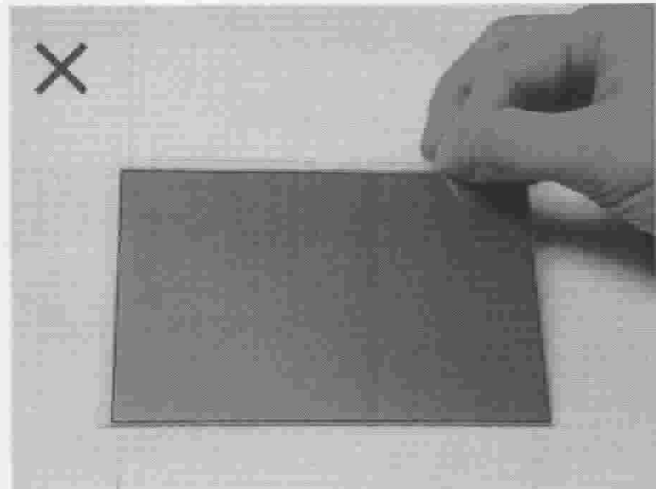

Please don't touch ITO glass without anti-static gloves.

