

NAN YA PLASTICS CORPORATION

SPECIFICATION OF  
LCD MODULE  
PRODUCT NO.: LMBHAT014G16CKS\_

SPEC. NO.: LM014-16G-

CUSTOMER
APPROVED BY
DATE :

LCD DEPARTMENT  
ELECTRONIC MATERIALS DIVISION  
NAN YA PLASTICS CORPORATION  
201, TUNG HWA N. ROAD, TAIPEI  
TEL: 886-2-27122211 EXT. 5993~5995  
FAX: 886-2-27178253  
E-mail: lcdsales@npc.com.tw

EDITED ON. : MAR.31, 2006

Q.C. DEPT.	DESIGN MANAGER	DESIGN CHECK	DESIGNER
			J.P. Weng



# 1. MECHANICAL DATA

NO	ITEM	CONTENTS	UNIT
1	Product No.	LMBHAT014G16CKS_	-
2	Module Size	170.0(W) X 102.0(H) X MAX14.0(D)	mm
3	Dot Size	0.47 (W) x 0.47 (H)	mm
4	Dot Pitch	0.5 (W) x 0.5 (H)	mm
5	Number of Dots	240 (W) x 128 (H)	Dot
6	Duty	1/128	-
7	LCD Display Mode	FSTN : Normal Black/Negative Image	-
8	Rear Polarizer	Transmission	-
9	Viewing Direction	6	O'clock
10	Backlight	CCFL	-
11	Controller	AX6963	-
12	DC/DC Converter	Excluded	-
13	Weight	235 (approx.)	g
14	Soldering	Lead Free	-

Note :

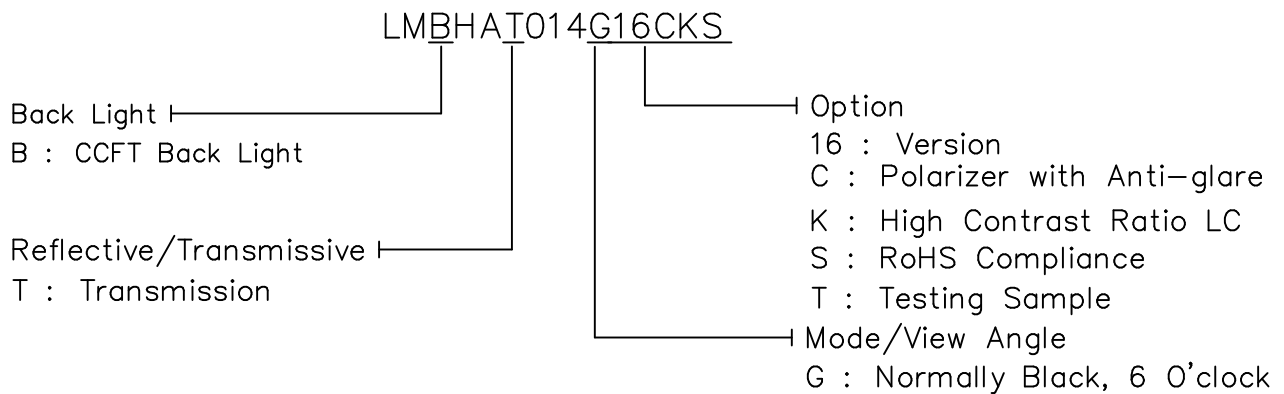

## RoHS Compliance.

Nan Ya guarantees that this project doesn't include any materials (6 materials) or includes less than specified quantities which are regulated by RoHS Compliance.

## 2. ABSOLUTE MAXIMUM RATINGS

### (1) ELECTRICAL ABSOLUTE RATINGS

VSS=0V

	SYMBOL	MIN.	MAX.	UNIT	COMMENT
Power Supply for Logic	VDD-VSS	-0.3	5.5	V	
Power Supply for LCD Driver	VDD-VEE	0	20.0	V	
Input Voltage	VI	-0.3	VDD	V	
Static Electricity	-	-	-	-	Note 1

Note 1 LCM should be grounded during handling LCM.

### (2) ENVIRONMENTAL ABSOLUTE MAXIMUM RATINGS

ITEM	WIDE TEMP.			
	OPERATING		STORAGE	
	MIN.	MAX.	MIN.	MAX.
Ambient Temperature	-20	70	-40	80
Humidity (Without Condensation)	Note 2,4		Note 3,4	

Note 2  $T_a \leq 70^\circ\text{C}$  : 75%RH max

Note 3 Please refer to item of reliability test.

Note 4 Background color will change slightly depending on ambient temperature.

That phenomenon is reversible.

### 3. ELECTRICAL CHARACTERISTICS

#### 3-1. ELECTRICAL CHARACTERISTICS OF LCM

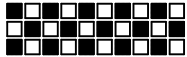
ITEM	SYMBOL	CONDITION		MIN.	TYP.	MAX.	UNIT	
Power Supply for Logic	VDD-GND	Ta=25°C		4.5	5.0	5.5	V	
Power Supply for LCD Driving	VDD-VEE	VDD=5.0V 1/128 Duty	-20°C	20.4	20.8	21.2	V	
			0°C	19.4	19.8	20.2		
			25°C	19.3	19.7	20.1		
			50°C	19.2	19.6	20.0		
			70°C	18.8	19.2	19.6		
Input Voltage	VIH	H level		0.9VDD	-	VDD	V	
	VIL	L level		GND	-	0.3VDD		
Supply Current (LCD)	IDD	VDD = 5.0V VEE = -14.7V		-	12.2	18.3	mA	
	IEE			-	4.3	6.5		
LCM Surface Luminance	L	T014G16	VDD=5.0V VEE=-14.7V IL=5mA @ Vin=10.8V for Inverter TDK CXA-L10L	PATTERN: DOTS ALL ON	128	160	-	cd/m <sup>2</sup>
				PATTERN: DOTS ALL OFF	-	24	36	

### 3-2.ELECTRICAL CHARACTERISTICS OF BACKLIGHT

Used CCFL Rating

Temp.=25°C

ITEM	SYMBOL	MIN.	TYP.	MAX.	UNIT	REMARK
Lamp voltage	V <sub>L</sub>	-	385	-	Vrms	-
Lamp current	I <sub>L</sub>	4.0	5.0	6.0	mArms	-
Lamp power consumption	P <sub>L</sub>	-	1.93	-	W	(*1)
Starting voltage	V <sub>s</sub>	-	-	570	Vrms	At 25°C
		-	-	660	Vrms	At 0°C
Lamp life time	L <sub>L</sub>	50000	-	-	hrs	IL = 5.0mArms(*2)

(\*1) Power consumption excluded inverter loss .

(\*2) Lamp life time is defined as follows : The final brightness is at 50% of original brightness .

### 3-3.ELECTRICAL CHARACTERISTICS OF RECOMMENDED INVERTER TDK CXA-L10L

#### 3-3-1 GENERAL SPECIFICATIONS

OPERATION TEMPERATURE : -10°C~60°C

STORAGE TEMPERATURE : -20°C~85°C

DIMENSION : MAX.44 (L)mm x MAX. 21(W)mm x MAX. 18(H)mm

#### 3-3-2 PIN ASSIGNMENTS

INPUT (CN1) CONNECTOR :

OUTPUT (CN2) CONNECTOR :

NO.	FUNCTION
1	VIN
2	GND

NO.	FUNCTION
3	OUT1
4	OUT2
5	OUT GND

#### 3-3-3 RELATIONSHIP BETWEEN VIN & TUBE CURRENT

ITEM	SYMBOL	MIN.	TYP.	MAX.	UNIT	REMARK
Input Voltage	VIN	-	10.8	-	V	
Tube Current	IL	-	5	-	mA	

## 4. OPTICAL CHARACTERISTICS

AT Vop

ITEM  MODE		Cr(Contrast Ratio)										$\theta$ (Viewing Angle)		$\phi$ (Viewing Angle)	
		-20°C		0°C		25°C		50°C		70°C		25°C		25°C	
		MIN.	TYP.	MIN.	TYP.	MIN.	TYP.	MIN.	TYP.	MIN.	TYP.	MIN.	TYP.	MIN.	TYP.
T	G	5.5	8	7	10	7	10	4.5	7.	4	6.5	-	60	-	±50
Note		NOTE 6										NOTE 5			

Note:

T : Transmission

G : Normally Back, 6 O'clock

AT  $\phi=0^\circ$   $\theta=0^\circ$

ITEM	SYMBOL	CONDITION	MIN.	TYP.	MAX.	UNIT	NOTE
Response Time (rise)	Tr	-20℃	—	2700	4100	ms	NOTE 2
		0℃	—	600	900		
		25℃	—	200	300		
		50℃	—	110	170		
		70℃	—	90	140		
Response Time (fall)	Tf	-20℃	—	1400	2100	ms	NOTE 2
		0℃	—	300	450		
		25℃	—	130	200		
		50℃	—	70	110		
		70℃	—	40	60		

(NOTE 1)

Definition of Operation Voltage(Vop)

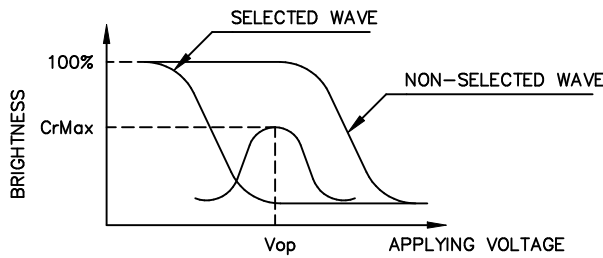

(positive type)

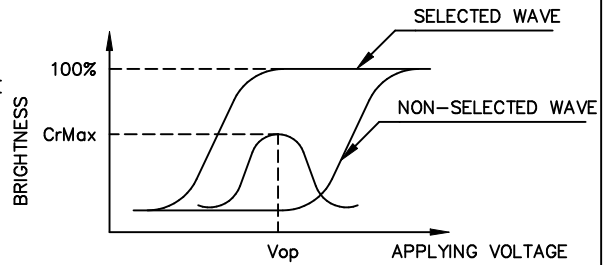

(negative type)

\*Conditions

Viewing Angle : 0  
Frame Frequency : 70Hz  
Applying Waveform : 1/N duty 1/a bias

(NOTE 2)

Definition of Response Time(Tr,Tf)

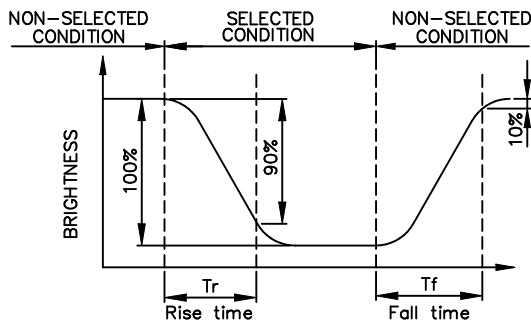

(positive type)

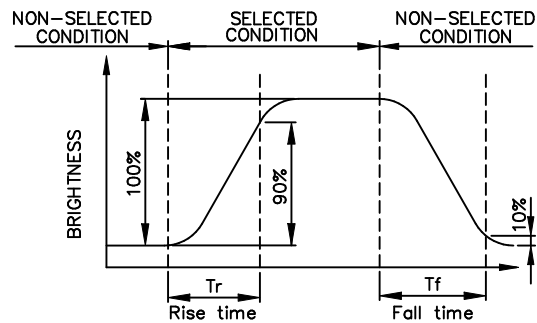

(negative type)

\*Conditions

Operating Voltage : Vop  
Viewing Angle ( $\theta, \phi$ ) : (0,0)  
Frame Frequency : 70Hz  
Applying Waveform : 1/N duty 1/a bias

(NOTE 3)

Description of Measuring Equipment and Driving Waveforms

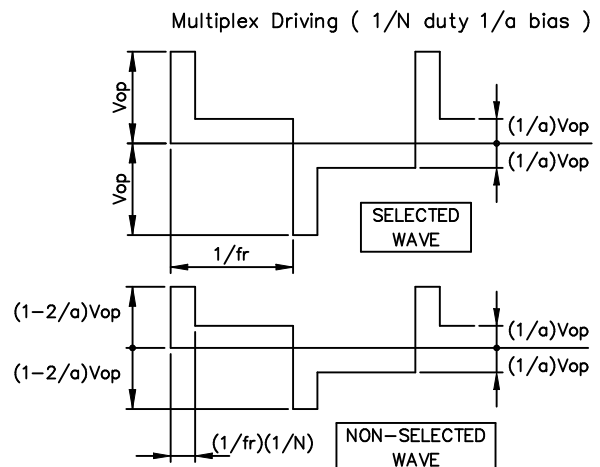
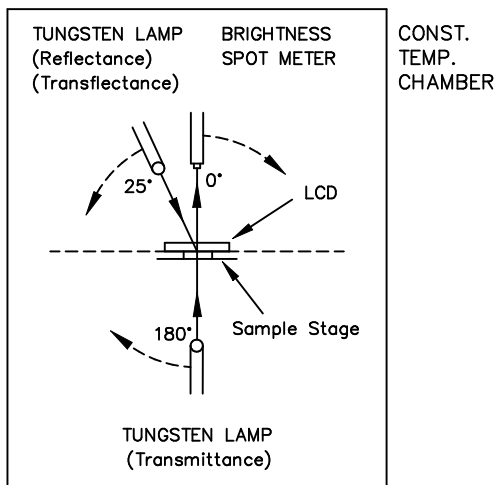

(NOTE 4)

Definition of Viewing Direction

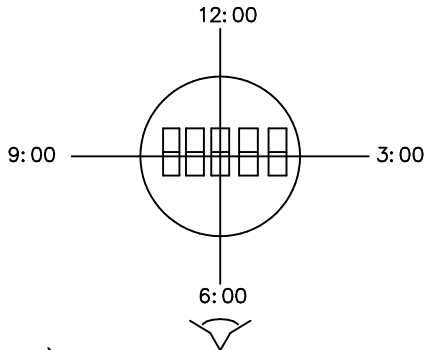

(NOTE 5)

Definition of Viewing Angle

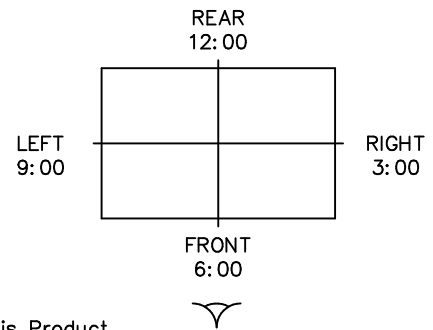
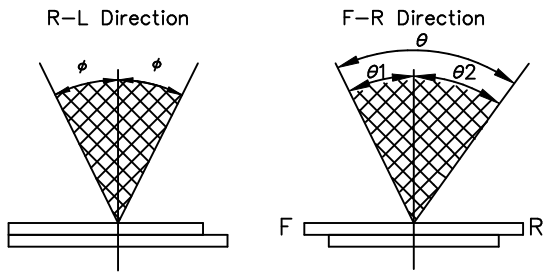

\*For This Product  
 The Viewing Direction Is 6 O'clock  
 So  $\theta_1 > \theta_2$

$$\theta = \theta_1 + \theta_2$$

\*Conditions

Operating Voltage :  $V_{op}$   
 Frame Frequency : 70Hz  
 Applying Waveform : 1/N duty 1/a bias  
 Contrast Ratio : larger than 2

(NOTE 6)

Definition of Contrast Ratio (Cr)

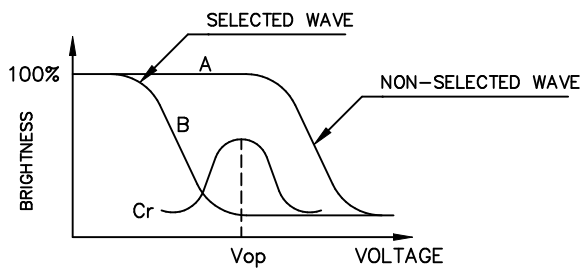

(positive type)

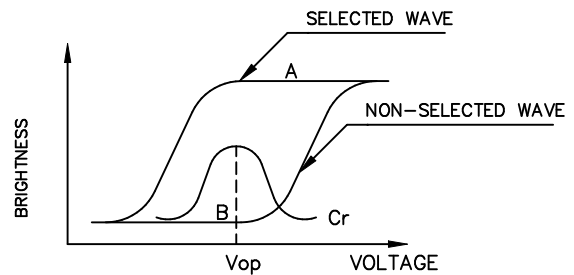

(negative type)

$$\text{Contrast Ratio : } Cr = A/B$$

\*Conditions

Viewing Angle : 0  
 Frame Frequency : 70Hz  
 Applying Waveform : 1/N duty 1/a bias

## 5. BLOCK DIAGRAM

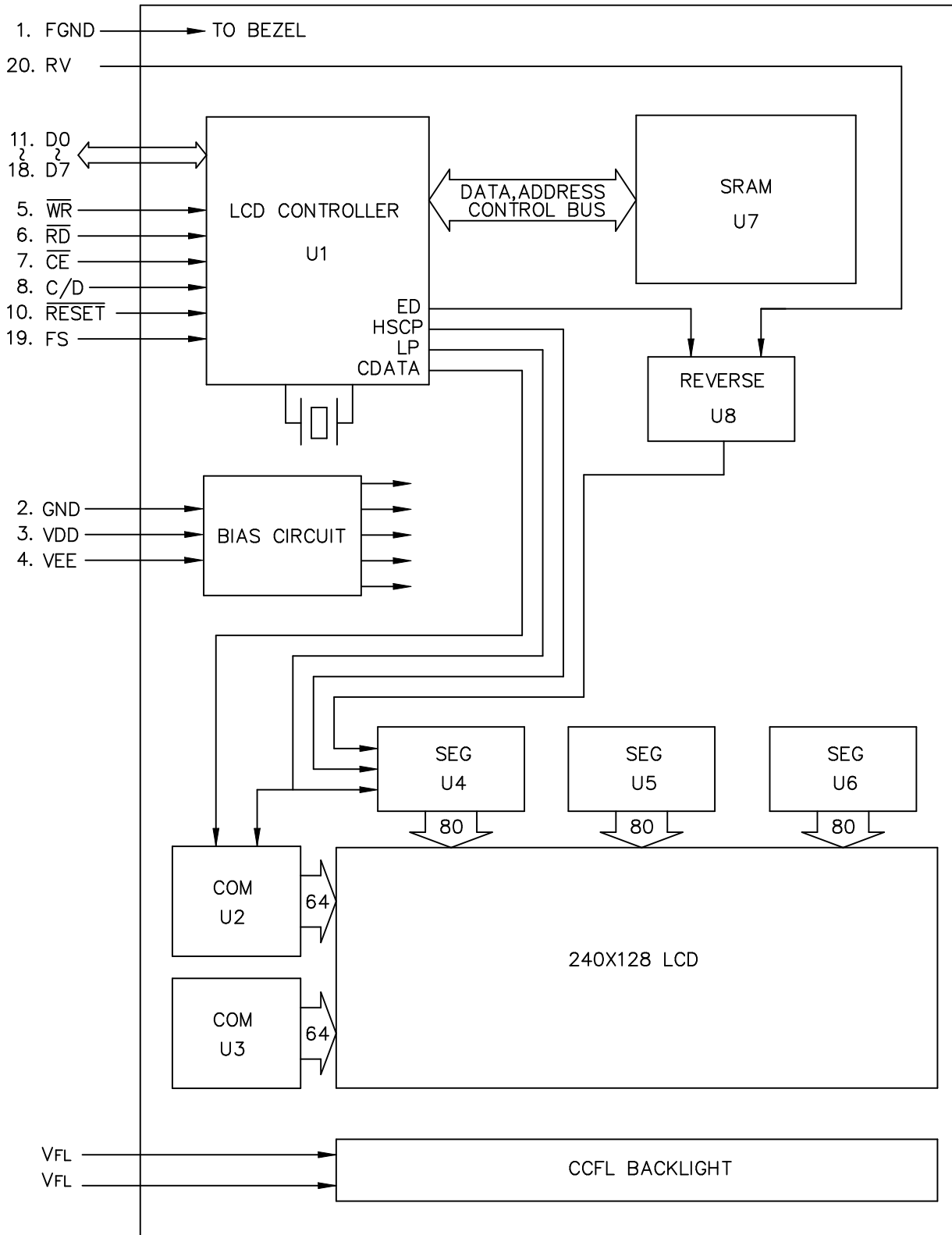



## 7. POWER SUPPLY

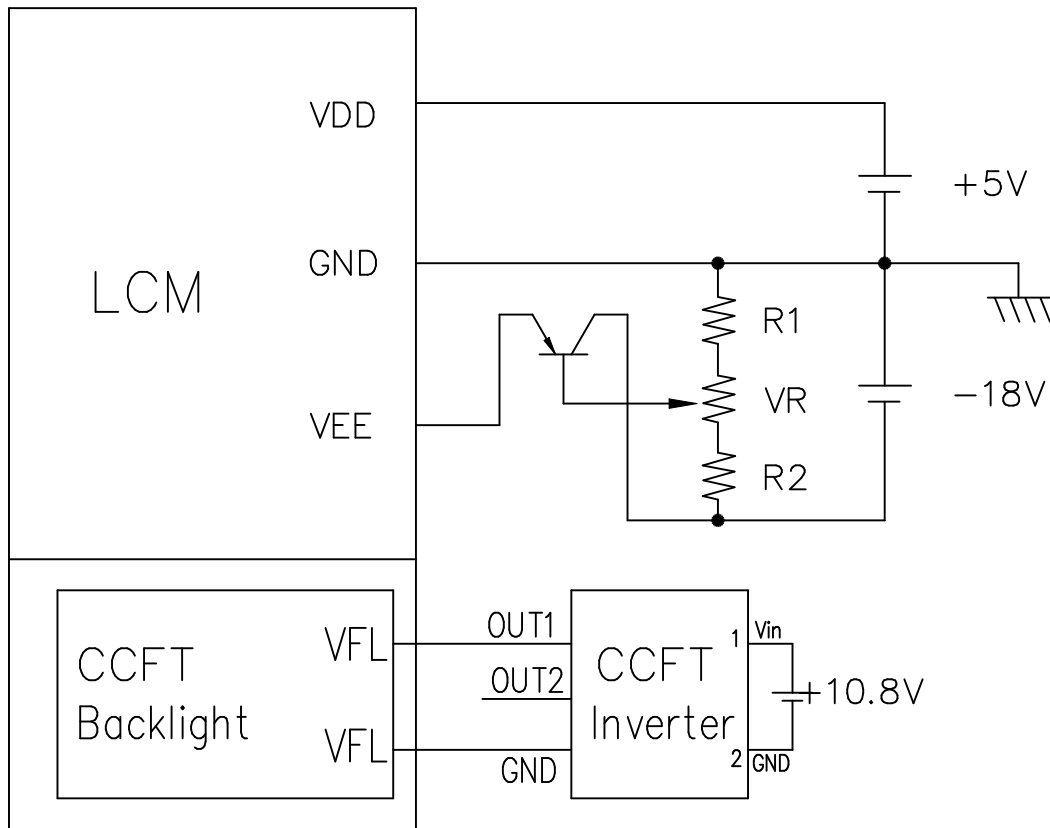

1.  $R1 + VR + R2 = 10K \sim 20K$
2. Recommended CCFL Inverter : TDK CXA-L10L  
@  $V_{in} = 10.8V$

# 8. TIMING CHARACTERISTICS

## 8-1. INTERFACE TIMING

@VDD = 5V±10%

ITEM	ITEM	CONDITION	MIN.	MAX.	UNIT
C/D SET UP TIME	$t_{CDS}$	Fig.	100	-	ns
C/D HOLD TIME	$t_{CDH}$	Fig.	10	-	ns
$\overline{CE}, \overline{RD}, \overline{WR}$ CLOCK WIDTH	$t_{CP}, t_{RP}, t_{WP}$	Fig.	80	-	ns
DATA SET UP TIME	$t_{DS}$	Fig.	80	-	ns
DATA HOLD TIME	$t_{DH}$	Fig.	40	-	ns
ACCESS TIME	$t_{ACC}$	Fig.	-	150	ns
DATA OUTPUT HOLD TIME	$t_{OH}$	Fig.	10	50	ns

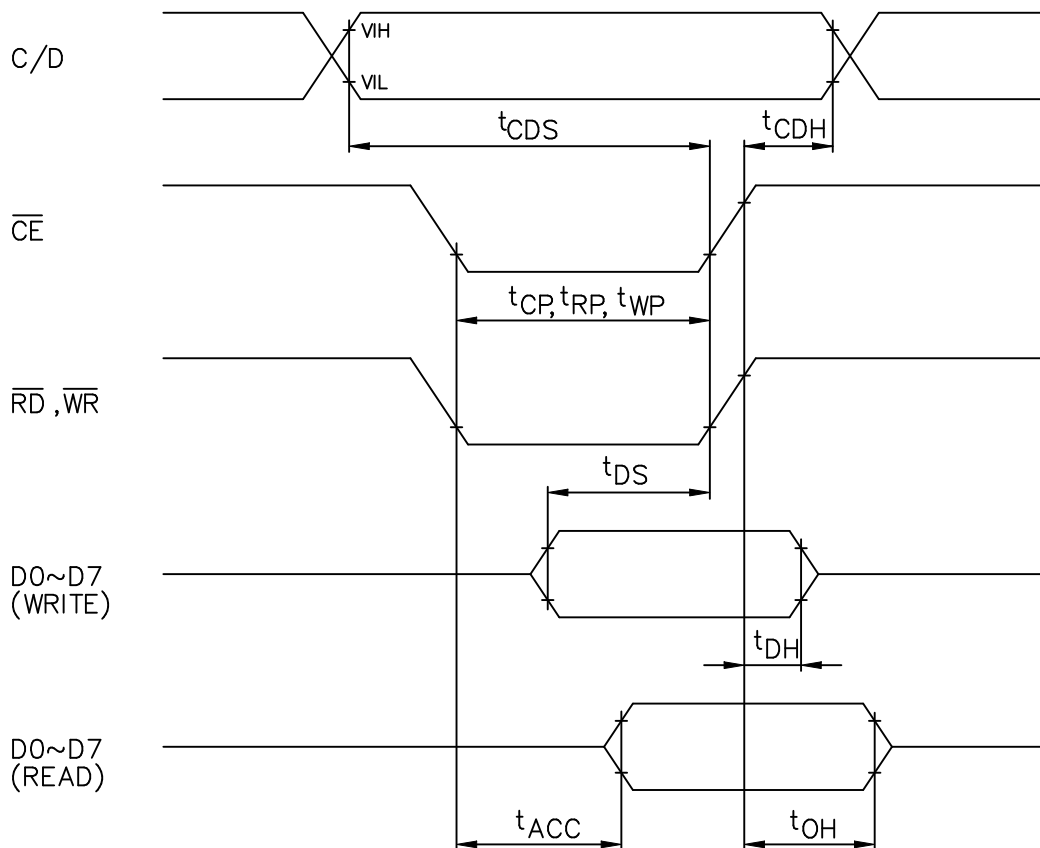
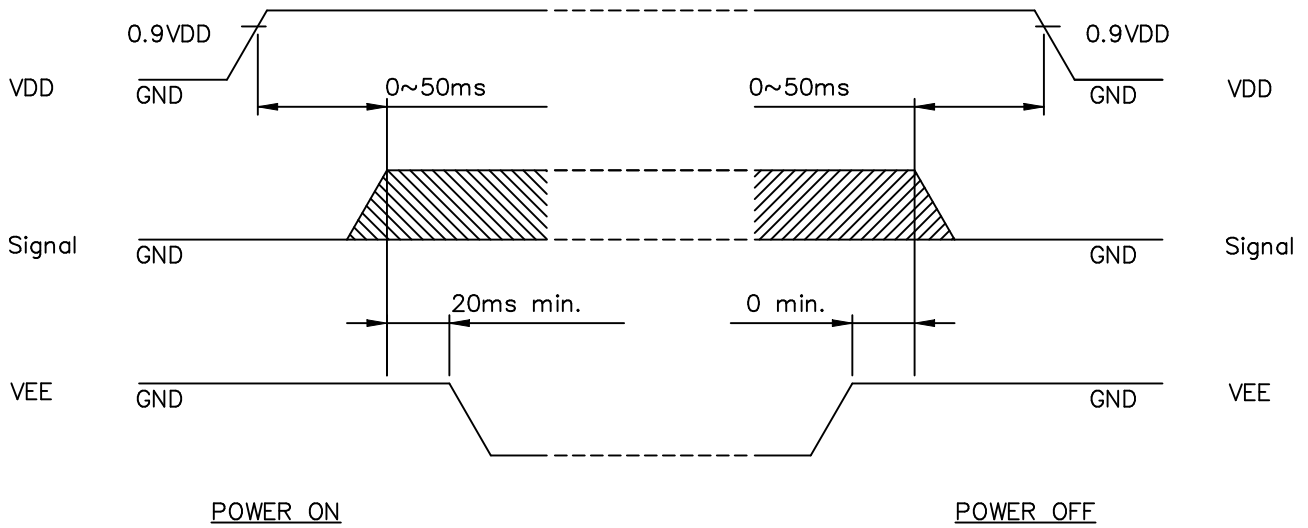

Fig. INTERFACE TIMING CHART

### 8-2. POWER ON/OFF TIMING



The missing pixels may occur when the LCM is driven beyond above power interface sequence.

### 8-3. DISPLAY PATTERN

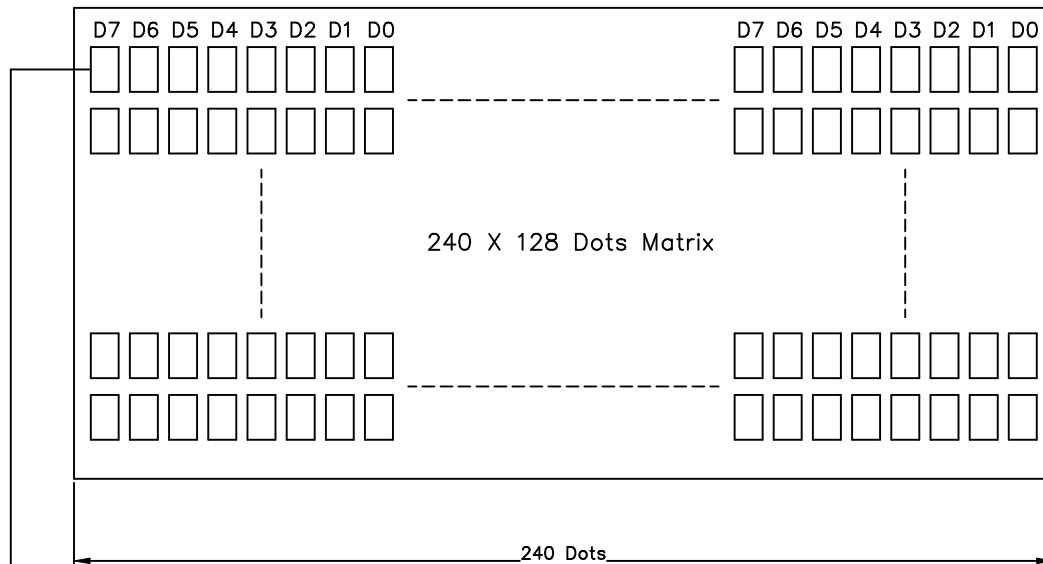

Starting dot for the starting address of display RAM.

D0~D7 are 8 bits transmitted data, where D0 is LSB and D7 is MSB.

8-4.COMMAND LIST

COMMAND	CODE	D1	D2	FUNCTION
REGISTER SET	00100001	X address	X address	Cursor pointer set
	00100010	Data	OOH	Offset register set
	00100100	Low address	High address	Address pointer set
CONTROL WORD SET	01000000	Low address	High address	Text home address set
	01000001	Columns	OOH	Text area set
	01000010	Low address	High address	Graphic home address set
	01000011	Columns	OOH	Graphic area set
MODE SET	1000X000	—	—	"OR" mode
	1000X001	—	—	"EXOR" mode
	1000X011	—	—	"AND" mode
	1000X100	—	—	"Text attribute" mode
	10000XXX	—	—	Internal CG ROM mode
	10001XXX	—	—	External CG RAM mode
DISPLAY MODE	10010000	—	—	Display off
	1001XX10	—	—	Cursor on, blink off
	1001XX11	—	—	Cursor on, blink on
	100101XX	—	—	Text on, graphic off
	100110XX	—	—	Text off, graphic on
	100111XX	—	—	Text on, graphic on
CURSOR PATTERN SELECT	10100000	—	—	1 line cursor
	10100001	—	—	2 lines cursor
	10100010	—	—	3 lines cursor
	10100011	—	—	4 lines cursor
	10100100	—	—	5 lines cursor
	10100101	—	—	6 lines cursor
	10100110	—	—	7 lines cursor
	10100111	—	—	8 lines cursor
DATA AUTO READ/WRITE	10110000	—	—	Data auto write set
	10110001	—	—	Data auto read set
	10110010	—	—	Auto reset
DATA READ WRITE	11000000	Data	—	Data write and ADP increment
	11000001	—	—	Data read and ADP increment
	11000010	Data	—	Data write and ADP decrement
	11000011	—	—	Data read and ADP decrement
	11000100	Data	—	Data write and ADP nonvariable
	11000101	—	—	Data read and ADP nonvariable
SCREEN PEEK	11100000	—	—	Screen peek
SCREEN COPY	11101000	—	—	Screen copy
BIT SET/RESET	11110XXX	—	—	bit reset
	11111XXX	—	—	bit set
	1111X000	—	—	bit0(LSB)
	1111X001	—	—	bit1
	1111X010	—	—	bit2
	1111X011	—	—	bit3
	1111X100	—	—	bit4
	1111X101	—	—	bit5
	1111X110	—	—	bit6
1111X111	—	—	bit7(MSB)	

**\* STATUS READ**

Before sending data (read/write), command it is necessary to check the status.

AX6963 status word format is following :

LSB	D0	STA0	Check capability of command execution	0: Disable 1: Enable
	D1	STA1	Check capability of data read/write	0: Disable 1: Enable
	D2	STA2	Check capability of auto mode data read	0: Disable 1: Enable
	D3	STA3	Check capability of auto mode data write	0: Disable 1: Enable
	D4	STA4	Not use	
	D5	STA5	Check capability of controller operation	0: Disable 1: Enable
	D6	STA6	Error flag. Using screen peek/copy command	0: Disable 1: Enable
MSB	D7	STA7	Check the condition blink	0: Disable 1: Enable

Note 1: It is necessary to check STA0 and STA1 at the same time. The error is happened by sending data at executing command.

Note 2: The status check will be enough to check STA0/STA1.

Note 3: STA2/STA3 are valid in auto mode STA0/STA1 are invalid.

Status checking flow

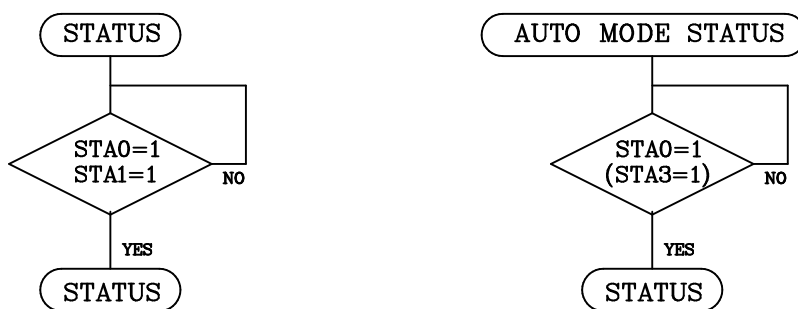

Note 4: It is impossible to save status check in the case of command of MSB0. To have the delay time cannot be save status check. The interrupt of hardware is happened at the end of lines. If command of MSB0 is sent in this period, the command executing is waited. The state of waiting doesn't disregarded or rewrites data of waiting command.

## 9. RELIABILITY TEST

### WIDE TEMPERATURE RELIABILITY TEST

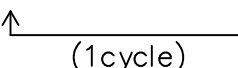
NO	ITEM	CONDITION			STANDARD	NOTE
1	High Temp. Storage	80°C	120Hrs		Appearance without defect	
2	Low Temp. Storage	-40°C	120Hrs		Appearance without defect	
3	High Temp. & High Humi. Storage	60°C 90%RH	120Hrs		Appearance without defect	
4	High Temp. Operating Display	70°C	120Hrs		Appearance without defect	
5	Low Temp. Operating Display	-20°C	120Hrs		Appearance without defect	
6	Thermal Shock	-20°C, 30min → 70°C, 30min 			Appearance without defect	10 cycles

### LCD VIBRATION & DROP TEST

NO	ITEM	CONDITIONS			RESULT
1.	Vibration Test	a.	5 → 13.95Hz 13.95 → 33Hz 33 → 51Hz 51 → 500Hz	Displacement: 0.2inch Acceleration: 2G Displacement: 0.036inch Acceleration: 5G	OK
		b.	Time 20 min. ± 1 min. X.Y.Z 3 Direction Total Time 60 min. ± 3 min.		
2.	Drop Test	Three-time free drop  In X.Y.Z direction  & One conner from a height of 70cm about ground			OK

Inspection Provision

1. Purpose

The NAN YA inspection provision provides outgoing inspection provision and its expected quality level based on our outgoing inspection of NAN YA LCD produces.

2. Applicable Scope

The NAN YA inspection provision is applicable to the arrangement in regard to outgoing inspection and quality assurance after outgoing.

3. Technical Terms

3-1 NAN YA Technical Terms

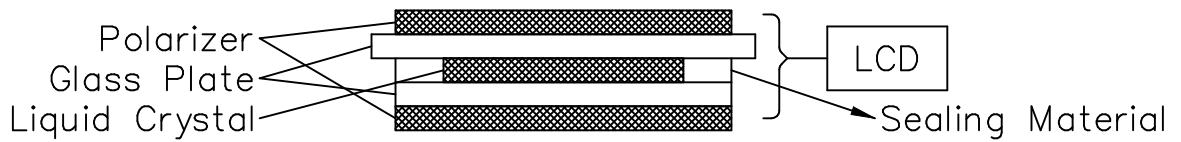

4. Outgoing Inspection

4-1 Inspection Method

MIL-STD-105E Level II Regular inspection

4-2 Inspection Standard

	Item		AQL(%)	Remarks
Major Defect	Dots	Opens Shorts Erroneous operation	0.4	faults which substantially lower the practicality and the initial purpose difficult to achieve.
	Solder appearance	Shorts Loose		
	Cracks	Display surface cracks		

	Dimensions	External from Dimensions	0.4	
Minor Defect	Inside the glass	Black spots	0.65	faults which appear to pose almost no obstacle to the practicality, effective use, and operation.
	Polarizing plate	Scratches, foreign Matter, air bubbles, and peeling		
	Dots	Pinhole, deformation		
	Color tone	Color unevenness		
	Solder appearance	Cold solder Solder projections		

4-3 Inspection Provisions  
\*Viewing Area Definition

Fig. 1

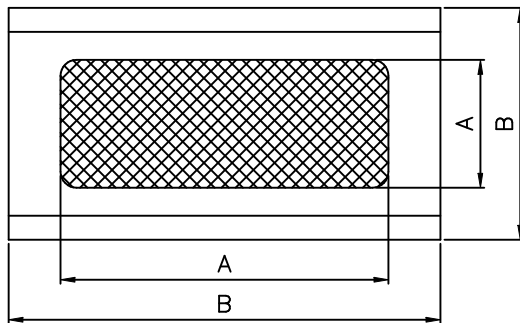

A : Zone Viewing Area  
B : Zone Glass Plate Out Line

\*Inspection place to be 500 to 1000 lux illuminance uniformly without glaring.  
The distance between luminous source(daylight fluorescent lamp and cool white fluorescent lamp) and a sample to be 30cm to 50cm.

\*Test and measurement are performed under the following conditions, unless otherwise specified.

Otherwise specified.

Temperature  $20 \pm 15^{\circ}\text{C}$   
Humidity  $65 \pm 20\% \text{R.H.}$   
Pressure 860~1060hPa(mmbar)

In case of doubtful judgment, it is performed under the following conditions.

Temperature  $20 \pm 2^{\circ}\text{C}$   
Humidity  $65 \pm 5\% \text{R.H.}$   
Pressure 860~1060hPa(mmbar)

5.Specification for quality check  
5-1 Electrical characteristics

NO.	Item	Criterion
1.	Non operational	Fail
2.	Miss operating	Fail
3.	Missing dot	Fail
4.	Contrast irregular	Fail
5.	Response time	Within Specified value
6.	CCFL backlight turn on/off	Within Specified value

5-2 External Appearance Defect

NO.	Item	Criterion																		
1.	Black spots, foreign matter, and white spots (Including light leakage due to pinholes of polarizing plates, etc.)	<p>(1)-1-Spots</p> <table border="1" data-bbox="711 477 1356 763"> <thead> <tr> <th>Average Diameter(mm):D</th> <th>Number of pieces permitted</th> </tr> </thead> <tbody> <tr> <td><math>D \leq 0.1</math></td> <td>Ignore</td> </tr> <tr> <td><math>0.1 &lt; D \leq 0.2</math></td> <td>5</td> </tr> <tr> <td><math>0.2 &lt; D \leq 0.3</math></td> <td>2</td> </tr> <tr> <td><math>0.3 &lt; D</math></td> <td>0</td> </tr> </tbody> </table> <p>Number of total pieces is set to within 5 pieces.</p> <p>Note that when there are 2 pieces or more, they are not to be concentrated. Set as: Average diameter = (Long diameter + Short diameter)/2</p> <p>(1)-2-Blurred Spots(At lighting condition)</p> <table border="1" data-bbox="711 1187 1356 1426"> <thead> <tr> <th>Average Diameter(mm):D</th> <th>Number of pieces permitted</th> </tr> </thead> <tbody> <tr> <td><math>D \leq 0.3</math></td> <td>Ignore</td> </tr> <tr> <td><math>0.3 &lt; D \leq 0.75</math></td> <td>5</td> </tr> <tr> <td><math>0.75 &lt; D</math></td> <td>0</td> </tr> </tbody> </table> <p>Number of total pieces is set to within 5 pieces.</p> <p>Note that when there are 2 pieces or more, they are not to be concentrated. Set as: Average diameter = (Long diameter + Short diameter)/2</p>	Average Diameter(mm):D	Number of pieces permitted	$D \leq 0.1$	Ignore	$0.1 < D \leq 0.2$	5	$0.2 < D \leq 0.3$	2	$0.3 < D$	0	Average Diameter(mm):D	Number of pieces permitted	$D \leq 0.3$	Ignore	$0.3 < D \leq 0.75$	5	$0.75 < D$	0
Average Diameter(mm):D	Number of pieces permitted																			
$D \leq 0.1$	Ignore																			
$0.1 < D \leq 0.2$	5																			
$0.2 < D \leq 0.3$	2																			
$0.3 < D$	0																			
Average Diameter(mm):D	Number of pieces permitted																			
$D \leq 0.3$	Ignore																			
$0.3 < D \leq 0.75$	5																			
$0.75 < D$	0																			

1.	Line	<p>(1)-1-Lines</p> <table border="1" data-bbox="715 421 1455 707"> <thead> <tr> <th>Width(mm): W</th> <th>Length(mm): L</th> <th>Number of pieces permitted</th> </tr> </thead> <tbody> <tr> <td><math>W \leq 0.03</math></td> <td>Ignore</td> <td>Ignore</td> </tr> <tr> <td><math>0.03 &lt; W \leq 0.08</math></td> <td><math>L \leq 4</math></td> <td>2</td> </tr> <tr> <td><math>0.08 &lt; W \leq 0.1</math></td> <td><math>L \leq 1</math></td> <td>1</td> </tr> </tbody> </table> <p>Object exceeding 0.1mm follow the standards of the spots form.          Note that when there are 2 pieces or more, they are not to be concentrated.</p> <p>(1)-2-Blurred Lines(At lighting condition)</p> <table border="1" data-bbox="715 1012 1455 1299"> <thead> <tr> <th>Width(mm): W</th> <th>Length(mm): L</th> <th>Number of pieces permitted</th> </tr> </thead> <tbody> <tr> <td><math>W \leq 0.03</math></td> <td>Ignore</td> <td>Ignore</td> </tr> <tr> <td><math>0.03 &lt; W \leq 0.08</math></td> <td><math>L \leq 3</math></td> <td>6</td> </tr> <tr> <td><math>0.08 &lt; W</math></td> <td><math>3 &lt; L</math></td> <td>None</td> </tr> </tbody> </table> <p>Object exceeding 0.1mm follow the standards of the spots form.          Note that when there are 2 pieces or more, they are not to be concentrated.</p>	Width(mm): W	Length(mm): L	Number of pieces permitted	$W \leq 0.03$	Ignore	Ignore	$0.03 < W \leq 0.08$	$L \leq 4$	2	$0.08 < W \leq 0.1$	$L \leq 1$	1	Width(mm): W	Length(mm): L	Number of pieces permitted	$W \leq 0.03$	Ignore	Ignore	$0.03 < W \leq 0.08$	$L \leq 3$	6	$0.08 < W$	$3 < L$	None
Width(mm): W	Length(mm): L	Number of pieces permitted																								
$W \leq 0.03$	Ignore	Ignore																								
$0.03 < W \leq 0.08$	$L \leq 4$	2																								
$0.08 < W \leq 0.1$	$L \leq 1$	1																								
Width(mm): W	Length(mm): L	Number of pieces permitted																								
$W \leq 0.03$	Ignore	Ignore																								
$0.03 < W \leq 0.08$	$L \leq 3$	6																								
$0.08 < W$	$3 < L$	None																								
2.	Scratches(Glass, reflection plates, and polarizing plates)	In accordance with black spots. (At non lighting condition)																								
3.	Color irregular	Not remarkable color irregular.																								

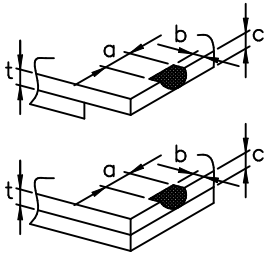
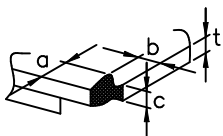
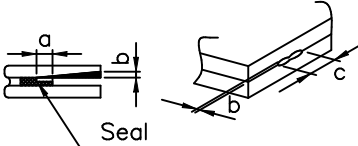
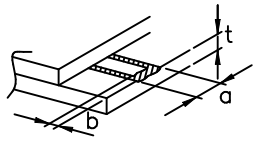
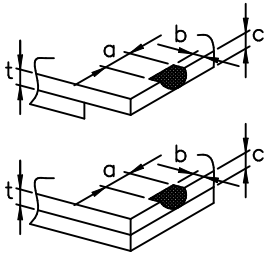
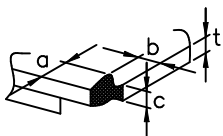
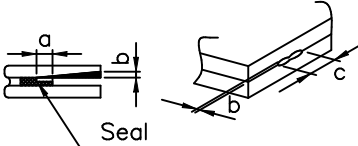
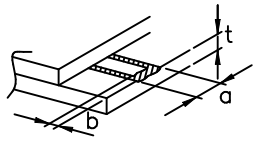
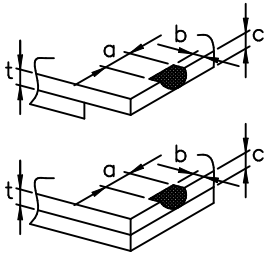
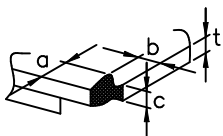
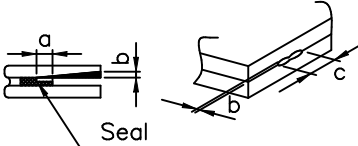
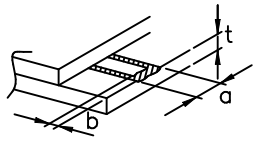
<p>4. Air bubbles polarizing plates, and reflection plates</p>	<table border="1" data-bbox="710 376 1225 667"> <tr> <th data-bbox="710 376 970 521">Average Diameter (mm): D</th> <th data-bbox="970 376 1225 521">Number of pieces permitted</th> <th data-bbox="1225 376 1476 667" rowspan="2">Average diameter = (Long diameter + Short diameter)/2</th> </tr> <tr> <td data-bbox="710 521 970 667">D ≤ 0.3 0.3 &lt; D</td> <td data-bbox="970 521 1225 667">Ignore 0</td> </tr> </table> <p data-bbox="710 683 1476 779">Note that when there are 4 pieces or more, they are not to be concentrated.</p>		Average Diameter (mm): D	Number of pieces permitted	Average diameter = (Long diameter + Short diameter)/2	D ≤ 0.3 0.3 < D	Ignore 0					
Average Diameter (mm): D	Number of pieces permitted	Average diameter = (Long diameter + Short diameter)/2										
D ≤ 0.3 0.3 < D	Ignore 0											
<p>5. Cracks</p>	<table border="1" data-bbox="662 779 1476 1964"> <tr> <td data-bbox="662 779 1066 1169"> <p>(1) General crack</p>  </td> <td data-bbox="1066 779 1476 1169"> <p>a ≤ 5 b ≤ 2 c ≤ t</p> <p>Where, a and b are ignored when less than or equal 0.5. The numbers of pieces are set at up to 5 pieces.</p> </td> </tr> <tr> <td data-bbox="662 1169 1066 1361"> <p>(2) Corner crack</p>  </td> <td data-bbox="1066 1169 1476 1361"> <p>a ≤ 2.5 b ≤ 2.5 c ≤ t a + b ≤ 4</p> </td> </tr> <tr> <td data-bbox="662 1361 1066 1635"> <p>(3) Seal portion crack</p>  </td> <td data-bbox="1066 1361 1476 1635"> <p>a ≤ The seal width × 1/3 b ≤ t × 2/3 c ≤ 5</p> <p>The numbers of pieces are set at up to 5 pieces.</p> </td> </tr> <tr> <td data-bbox="662 1635 1066 1870"> <p>(4) ITO Pin crack</p>  </td> <td data-bbox="1066 1635 1476 1870"> <p>a ≤ 5 b ≤ 1/3 pin length c ≤ t</p> </td> </tr> <tr> <td data-bbox="662 1870 1066 1964"> <p>(5) Progressive cracks</p> </td> <td data-bbox="1066 1870 1476 1964"> <p>All taken to be unacceptable.</p> </td> </tr> </table>		<p>(1) General crack</p> 	<p>a ≤ 5 b ≤ 2 c ≤ t</p> <p>Where, a and b are ignored when less than or equal 0.5. The numbers of pieces are set at up to 5 pieces.</p>	<p>(2) Corner crack</p> 	<p>a ≤ 2.5 b ≤ 2.5 c ≤ t a + b ≤ 4</p>	<p>(3) Seal portion crack</p> 	<p>a ≤ The seal width × 1/3 b ≤ t × 2/3 c ≤ 5</p> <p>The numbers of pieces are set at up to 5 pieces.</p>	<p>(4) ITO Pin crack</p> 	<p>a ≤ 5 b ≤ 1/3 pin length c ≤ t</p>	<p>(5) Progressive cracks</p>	<p>All taken to be unacceptable.</p>
<p>(1) General crack</p> 	<p>a ≤ 5 b ≤ 2 c ≤ t</p> <p>Where, a and b are ignored when less than or equal 0.5. The numbers of pieces are set at up to 5 pieces.</p>											
<p>(2) Corner crack</p> 	<p>a ≤ 2.5 b ≤ 2.5 c ≤ t a + b ≤ 4</p>											
<p>(3) Seal portion crack</p> 	<p>a ≤ The seal width × 1/3 b ≤ t × 2/3 c ≤ 5</p> <p>The numbers of pieces are set at up to 5 pieces.</p>											
<p>(4) ITO Pin crack</p> 	<p>a ≤ 5 b ≤ 1/3 pin length c ≤ t</p>											
<p>(5) Progressive cracks</p>	<p>All taken to be unacceptable.</p>											

6.	Outer dimensions	Should be with in the tolerance.
7.	Newton ring(touch panel)	Orbicular of interference fringes is not allowed in the optimum contrast within the active area under viewing angle.
8.	Soldering	Should be no defective soldering such as shorting, loose terminal cold solder, peeling of printed circuit board pattern, improper mouting position, etc.

5-3 Dot Appearance Defect

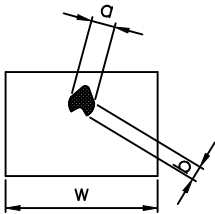
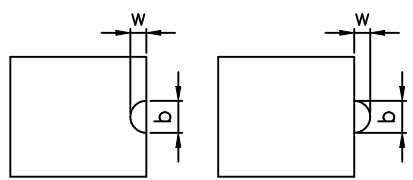
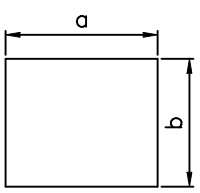
NO.	Item	Criteria
1.	Pinhole	 <p>Dot display a and b are each <math>\leq 0.2\text{mm}</math> The overall total is taken be with in 10 units. Note that they are not to be concentrated.</p>
2.	Missing	 <p>Dot display a and b are each <math>\leq 0.2\text{mm}</math> The overall total is taken to be with in 10 units.</p>
3.	Thick and thin display	 <p>Taken to be within <math>\pm 1.5\%</math> of display character width(a) and height(b).</p>

NOTE:

- SAFETY

- 1.If the LCD panel breaks, be careful not to get the liquid crystal to touch your skin.
- 2.If the liquid crystal touches your skin or clothes, please wash it off immediately by using soap and water.

- HANDLING

- 1.Avoid static electricity which can damage the CMOS LSI.
- 2.Do not remove the panel or frame from the module.
- 3.The polarizing plate of the display is very fragile. So, please handle it very carefully.
- 4.Do not wipe the polarizing plate with a dry cloth, as it may easily scratch the surface of plate.
- 5.Do not use ketonics solvent & Aromatic solvent, use a soft cloth soaked with a cleaning naphtha solvent.

- STORAGE

- 1.Store the panel or module in a dark place where the temperature is  $25^{\circ}\text{C}\pm 5^{\circ}\text{C}$  and the humidity is below 65% RH.
- 2.Do not place the module near organics solvents or corrosive gases.
- 3.Do not crush, shake, or jolt the module.

- TERMS OF WARRANT

- 1.Acceptance inspection period  
The period is within one month after the arrival of contracted commodity at the buyer's factory site.
- 2.Applicable warrant period  
The period is within twelve months since the date of shipping out under normal using and storage conditions.

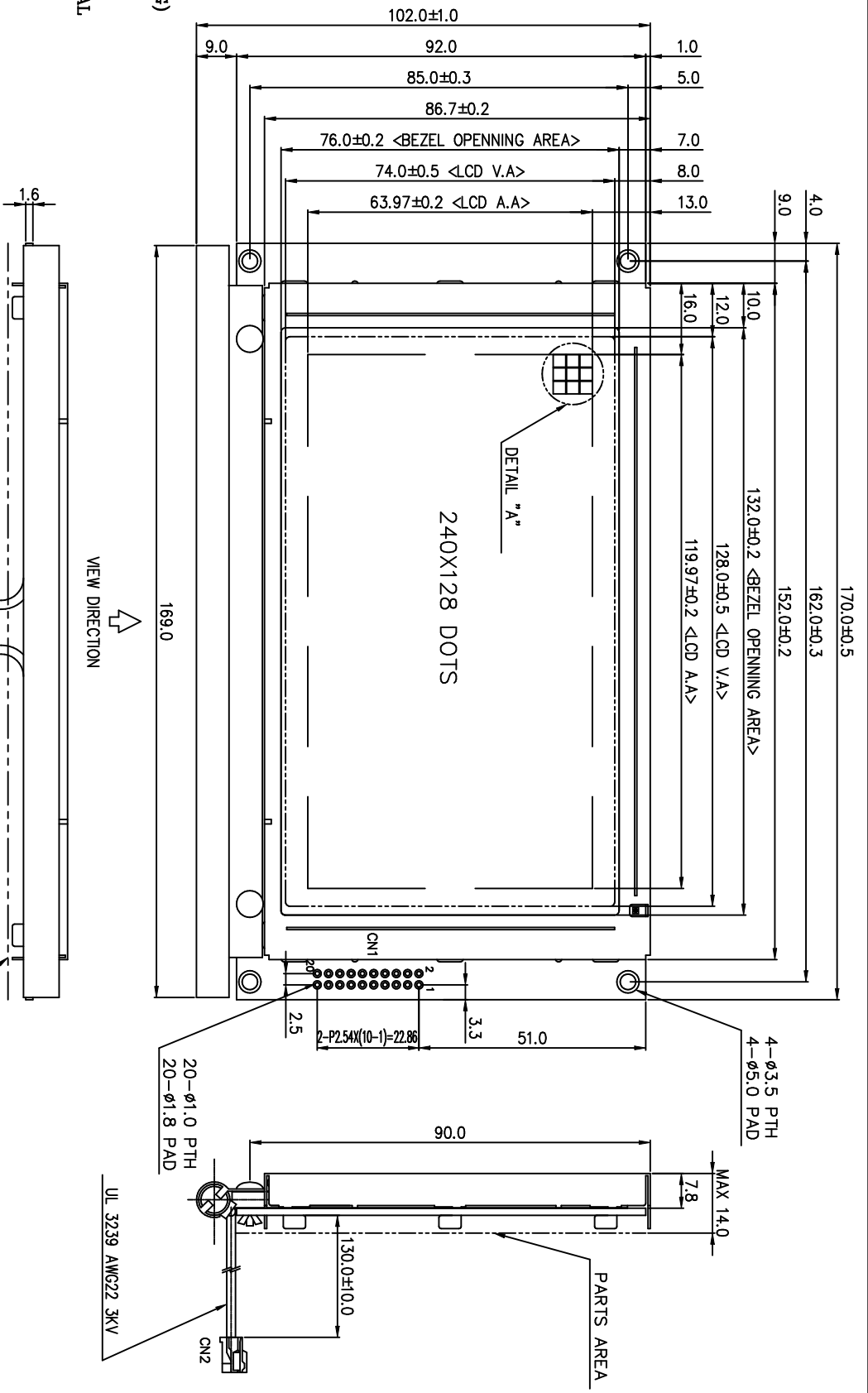
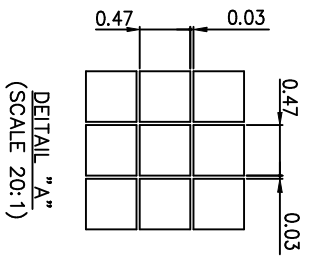

- NOTES :
1. RESOLUTION : 240 x 128 Dots
  2. CONTROLLER : AX6963
  3. DRIVER IC : NT7086 (COM/SEG)
  4. FRAME : SUS 304 (0.5mm t)
  5. BACKLIGHT : CCFL (WHITE)
  6. USED "K" TYPE LIQUID CRYSTAL

CN1 : PITCH 2.54mm

PIN NO.	SYMBOL	FUNCTION	PIN NO.	SYMBOL	FUNCTION
1	FGND	FRAME GROUND (0V)	15	D4	DATA INPUT/OUTPUT
2	GND	GROUND	16	D5	DATA INPUT/OUTPUT
3	VDD	POWER SUPPLY FOR LOGIC (+5V)	17	D6	DATA INPUT/OUTPUT
4	VEE	POWER SUPPLY FOR LC DRIVING	18	D7	DATA INPUT/OUTPUT
5	WR	DATA WRITE	19	FS	FONT SELECT CONNECT TO VDD : 800 PITCHES/CHARACTER CONNECT TO GND : 600 PITCHES/CHARACTER RW : NORMAL DISPLAY
6	RD	DATA READ	20	RV	DISPLAY DATA REVERSE
7	CE	CHIP ENABLE			
8	C/D	MC <sup>+</sup> /D <sup>+</sup> : COMMAND WRITE MC <sup>-</sup> /D <sup>-</sup> : STATUS READ			
9	NC	NO CONNECTION			
10	RESET	CONTROLLER RESET	1	VH	POWER SUPPLY FOR FL DRIVE
11	DO	DATA INPUT/OUTPUT	2	NC	NO CONNECTION
12	D1	DATA INPUT/OUTPUT	3	NC	NO CONNECTION
13	D2	DATA INPUT/OUTPUT	4	NC	NO CONNECTION
14	D3	DATA INPUT/OUTPUT	5	VH	POWER SUPPLY FOR FL DRIVE



DIMENSION	TOLERANCE
L ≤ 6	±0.25 (mm)
6 < L ≤ 18	±0.3 (mm)
18 < L ≤ 50	±0.4 (mm)
50 < L ≤ 125	±0.5 (mm)
125 < L	±0.6 (mm)
ANGLE	±1° (DEG)

REV. NO.	DESCRIPTION	DATE	DESIGN	CHECK	APPROVE
1	Modified the Bezel by the actual product	95.03.02	Compos Chen		

南亞塑膠工業股份有限公司  
NAN YA PLASTICS CORPORATION

製品圖  
LMBHAT014G16CKS

NAME	DATE	THIRD ANGLE P.
APPROVE TONY CHOU	94.12.12	
CHECK Y. C. Liu	94.12.08	
DESIGN Compos Chen	94.12.07	SCALE UNIT
DRAWN Compos Chen	94.12.07	1/1 mm

# THE NOTES OF LCM USING

LCM is easy to damage.

Please follow the notes as bellows, and be careful of handling!

## Correct handling

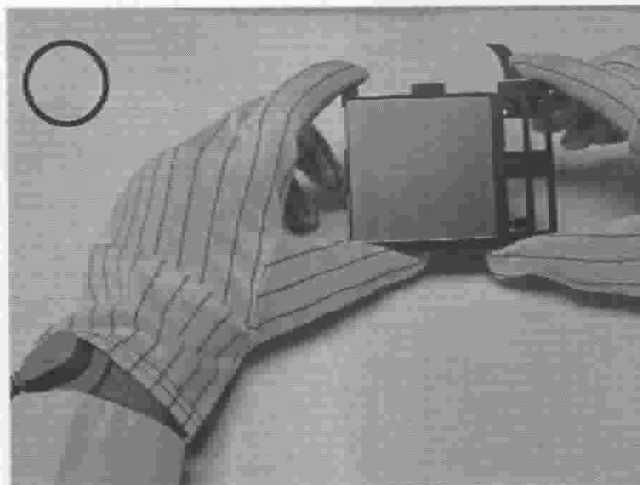
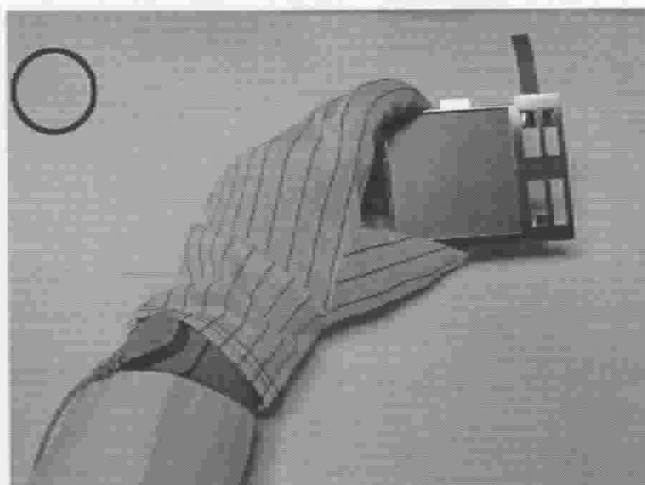

As above picture, please handle with glove by LCM edges and full EOS/ESD protection.

## Incorrect handling

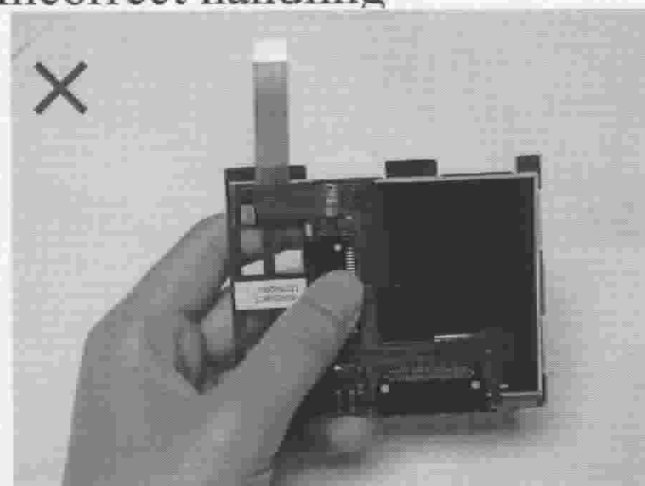

Please don't touch IC directly.

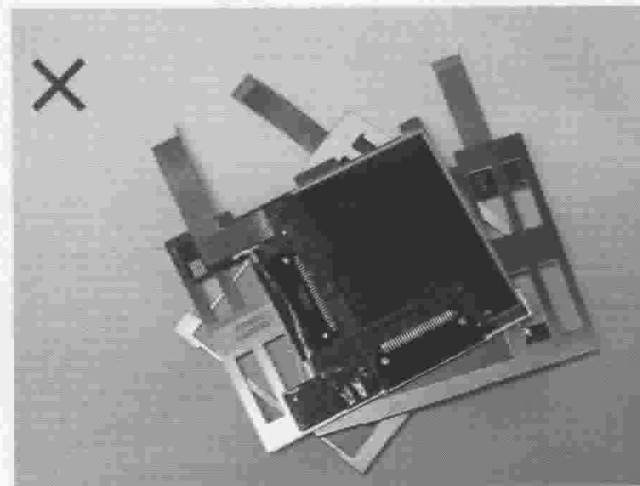

Please don't put one on another LCM.

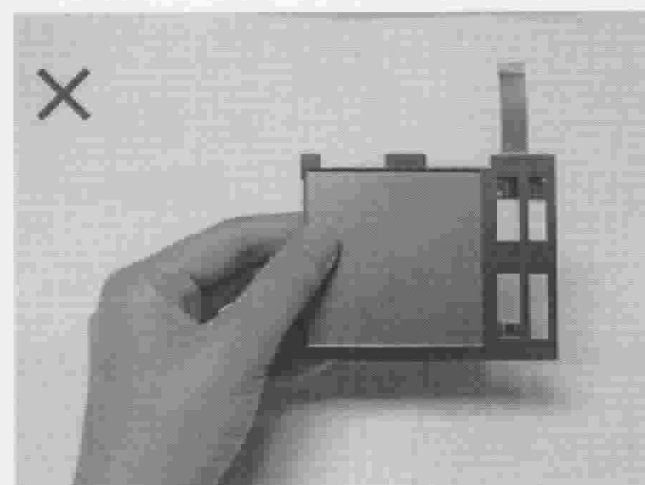

Please don't hold the surface of LCM.

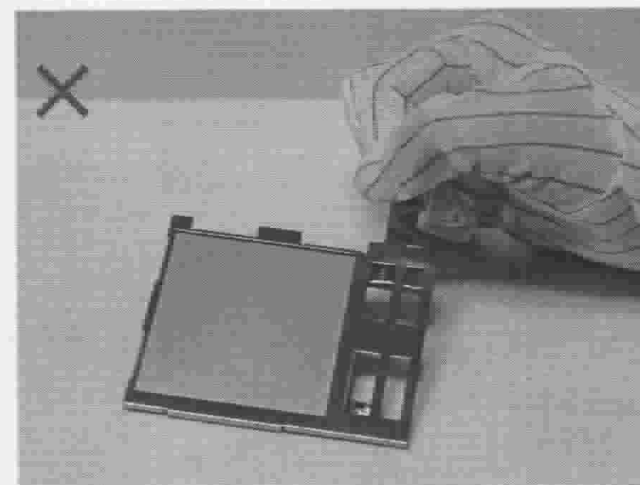

Please don't stretch interface of output.

# THE NOTES OF LCD USING

LCD is easy damage.

Please follow notes as bellows, and be careful of handling!

## Correct handling

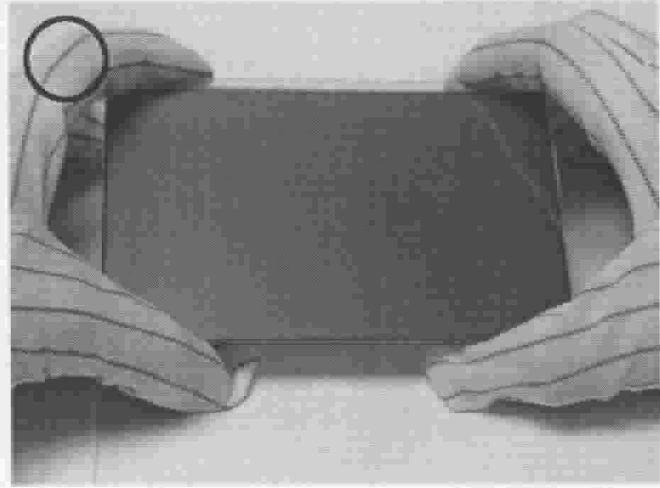
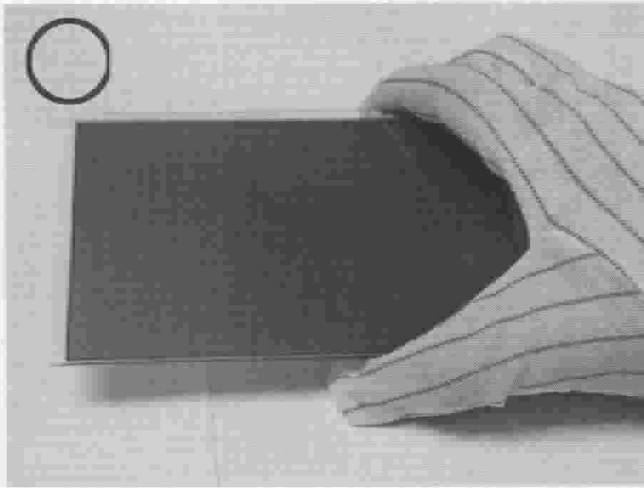

As above picture, please handle with glove by LCD edges and full EOS/ESD protection.

## Incorrect handling

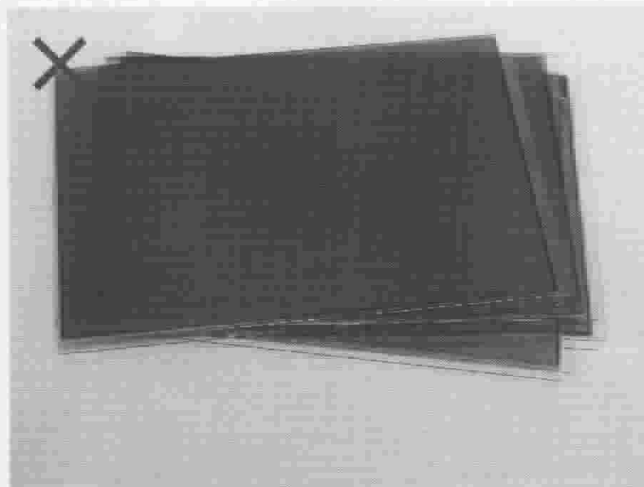

Please don't put one on another LCD.

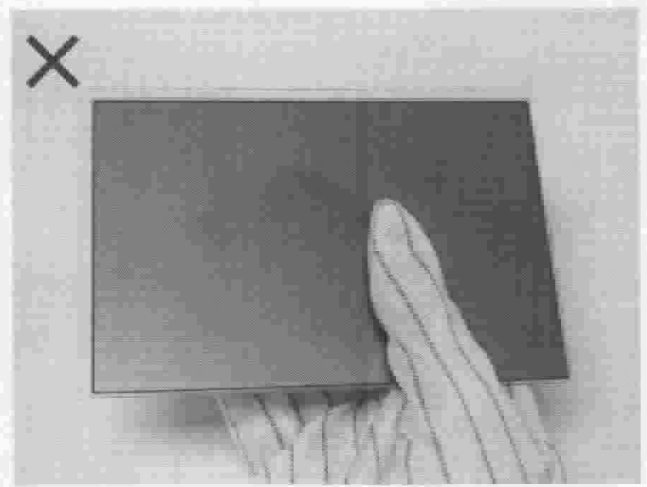

Please don't hold the surface of LCD.

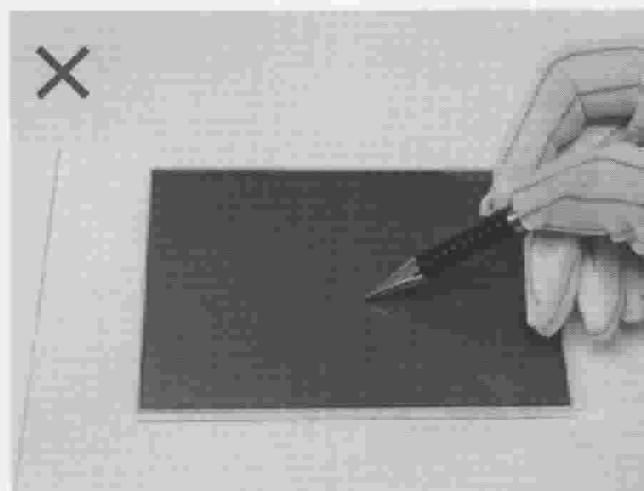

Please don't operate with sharp stick such as sharp pencil.

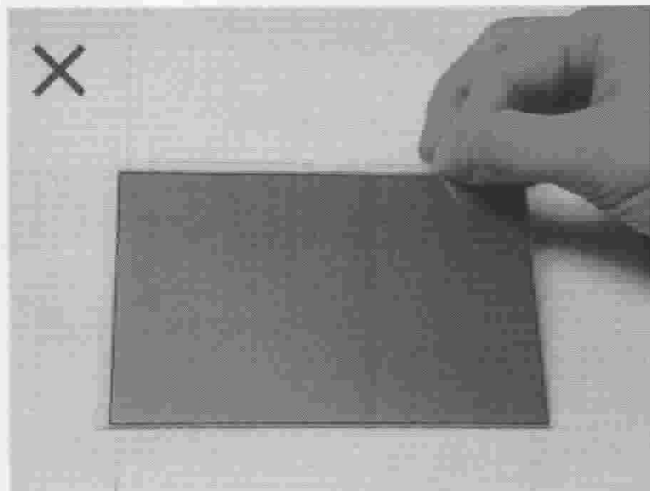

Please don't touch ITO glass without anti-static gloves.

